

# BALDOR®

A MEMBER OF THE ABB GROUP



## Fundamentals of Motors

Ray Hatcher – Industry Engineer  
Chemical, Oil and Gas



**Our mission is to be the best  
(as determined by our customers)  
marketers, designers and manufacturers  
of industrial electric motors, drives and  
mechanical power transmission products.**

# Our Strategy

To produce the highest quality, energy-efficient products available in the marketplace and sell them to a broad base of value-minded customers.

$$V_p = \frac{Q_p \times S_p}{C \times T}$$

$V_p$  = perceived Value

$Q_p$  = perceived Quality

$S_p$  = perceived Service

$C$  = Cost

$T$  = Time

# Baldor Industry Solutions – Greenville, SC



**DODGE**



*AC Motor Family*



# Baldor Industry Solutions – Greenville, SC

- Aggregate, Cement, and Sugar
- Ports
- Chemical, Oil, and Gas
- Food, Beverage, and Pharmaceutical
- Mining and Metals
- Paper and Forest Products
- Power Generation
- Air Handling
- Unit Handling
- Water and Wastewater



# Motor Fundamentals

- Induction Motor Principles
- Motor Performance Characteristics
  - › Speed/Poles
  - › Speed Torque Curve
  - › Starting
  - › Motor Efficiency
  - › Motor Service factor and Temperature
- Motor Standards
  - › NEMA MG-1
  - › IEEE 841
- Application Considerations
  - › Hazardous Areas
  - › Operating Motors on Inverters
- Common Failure Modes
- Motor Components

# AC Induction Motor

- An electric motor is a device that converts electrical energy into mechanical energy.
- The AC induction motor is the most common type of industrial motor.



# Induction Motor Principles



# Magnet Basics

- All magnets have a North and a South Pole
- “Opposite” poles of a magnet attract each other
- “Like” poles of a magnet repel each other.
- Motors use this principle of attraction and repulsion to rotate

Lines of Flux

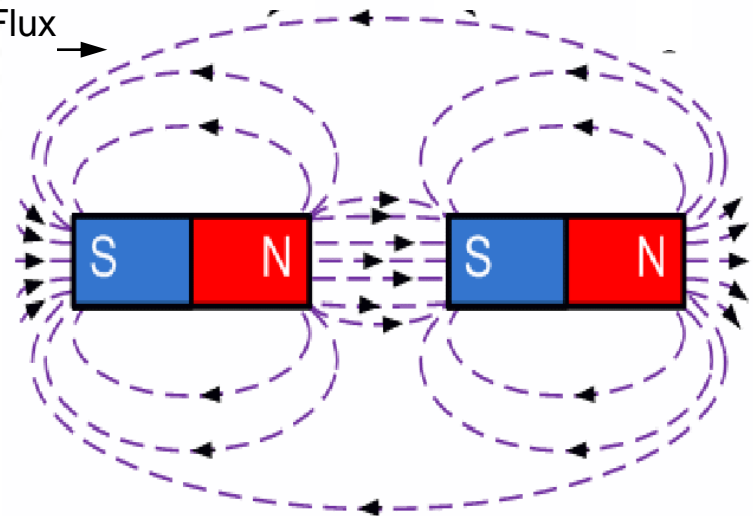

Two Unlike Poles Together Attract

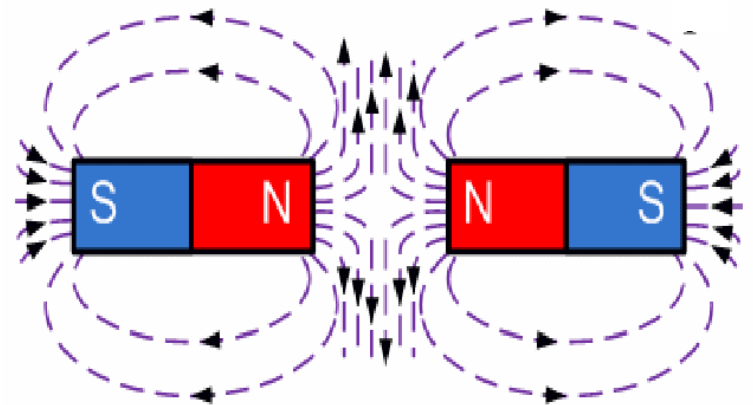

Two Like Poles Together Repel

# Magnetic Propulsion

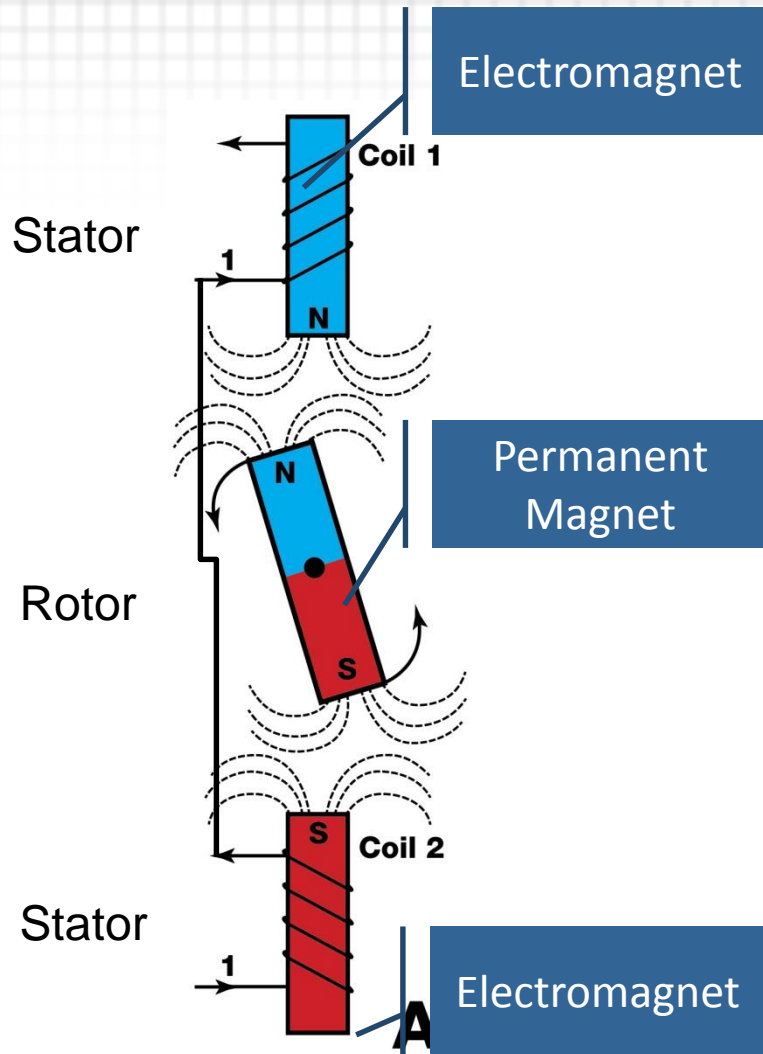

# Three Phase AC Power

## Why 3 phases?

- It allows the most power transfer with the minimum number of conductors
- Three times the power transfer of a single phase system by adding only one conductor
- The sum of all three phase voltage at any instant of time is zero

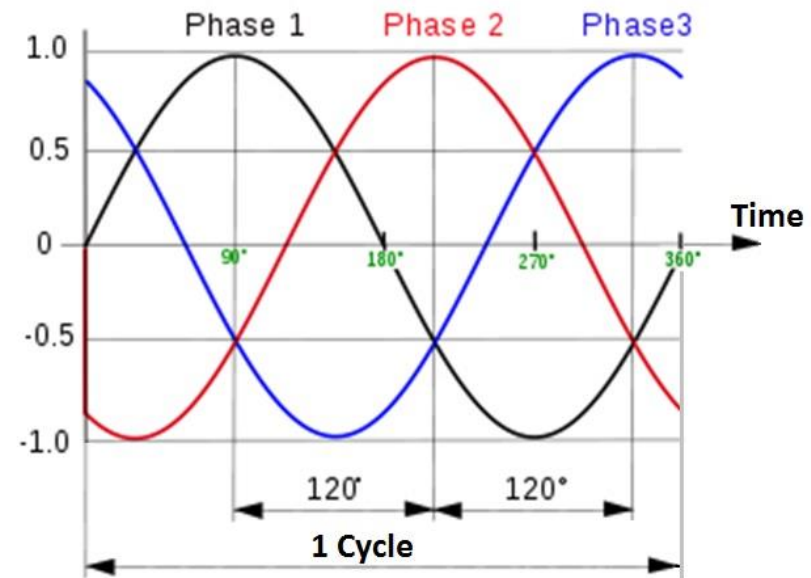

# Adding 3 Phases Together: Rotating Magnetic Field

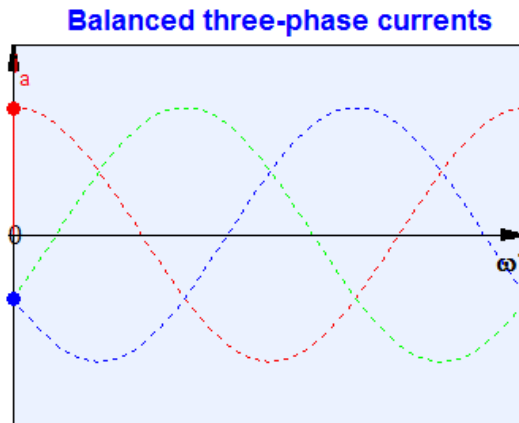

# Speed of the Field Depends on Number of Magnetic Poles formed when the motor is energized

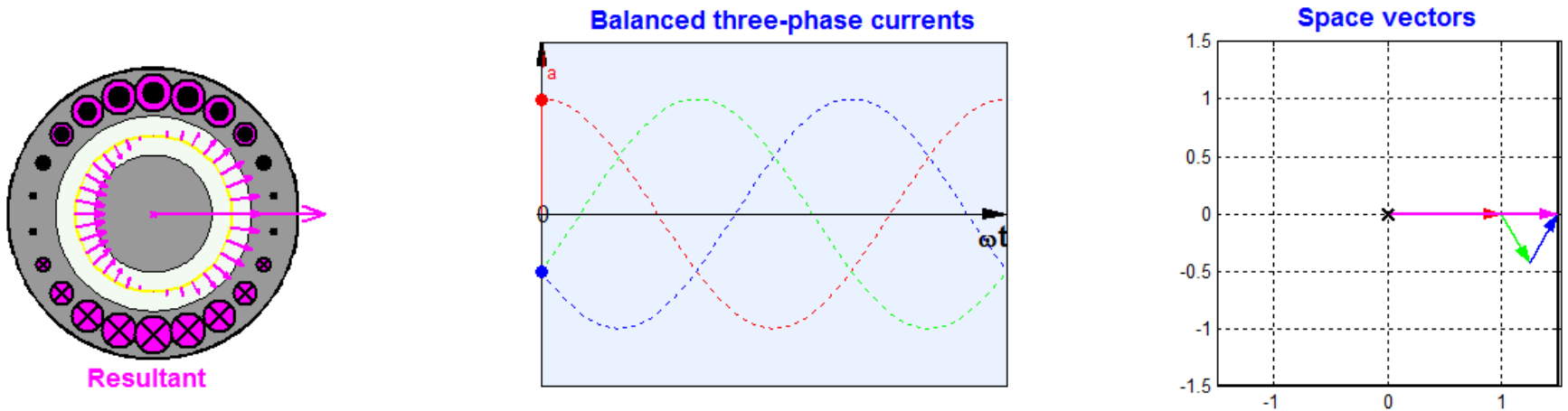

- This example is a Two Pole motor (1 North + 1 South)
- For every cycle of current, the flux vector (magnetic field) makes one revolution.
- Speed = 60 cycles \* 60 sec = 3600 rpm

# More Poles = Slower Speed??

- Additional windings can be added to a motor to create additional “Magnetic Pole Sets” in the motor.
- Poles are always in PAIRS. 2, 4, 6, 8.....
- The speed of the rotating magnetic field in the stator is **INVERSLY** proportional to the number of poles

$$\text{RPM} = \frac{120 \times \text{Freq}}{\# \text{ of Poles}}$$

# Poles	Speed (RPM)
2	3600
4	1800
6	1200

# Three Phase Induction Motor

- Three winding mechanically separated by 120 degrees
- Three phase current in stator produces a magnetic flux of constant magnitude rotating at synchronous speed
- Rotating flux “cuts” the rotor conductors causing EMF to be induced in rotor bars (Faraday’s Law).
- EMF in shorted rotor bars induces rotor current flow
- By Lenz’s law, the current flow in the rotor conductors creates mechanical force
- Result is the rotor turns in the direction of the magnetic field, trying to catch up

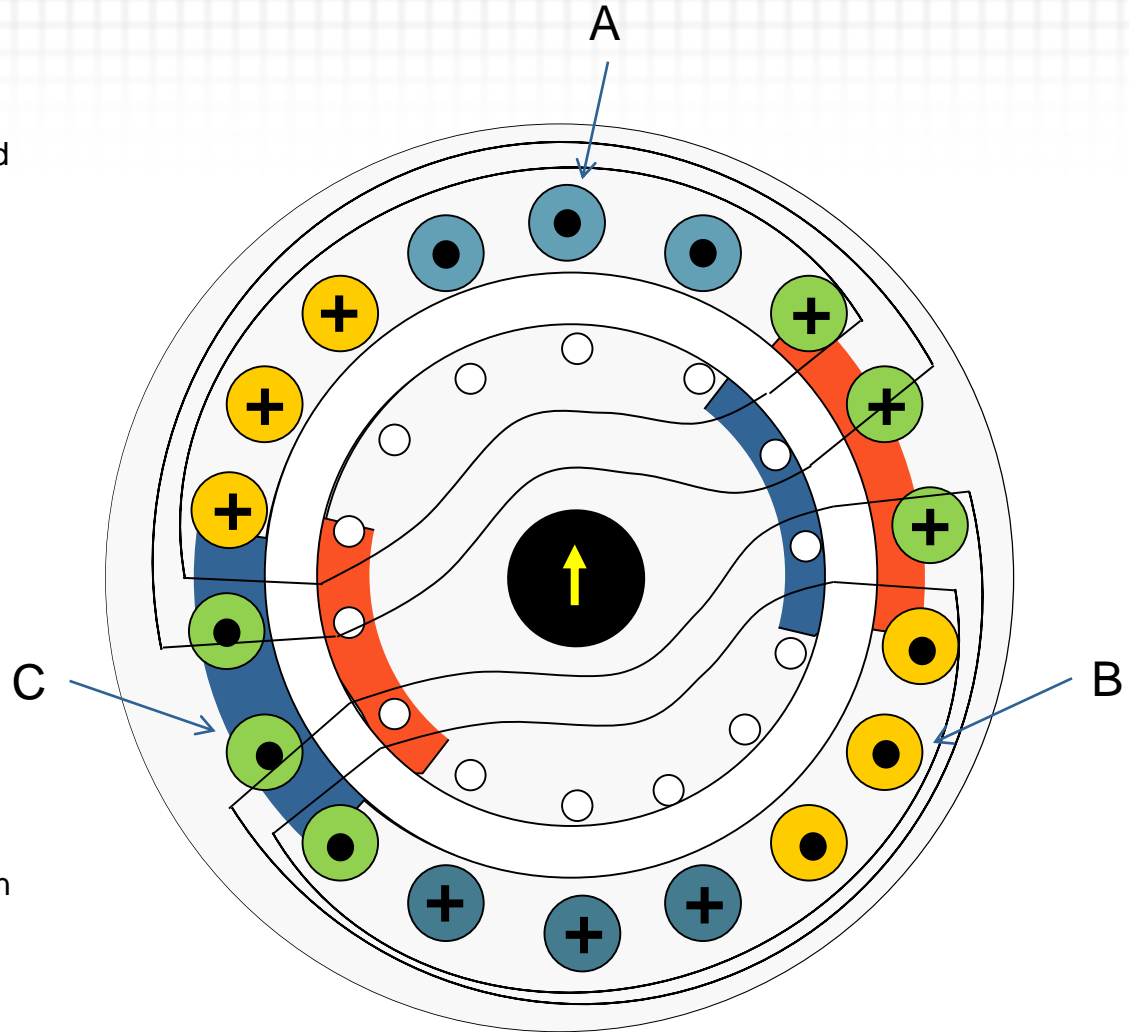

# What is Torque?

Torque is a force applied at a distance from and perpendicular to an axis.

1 Pound Force

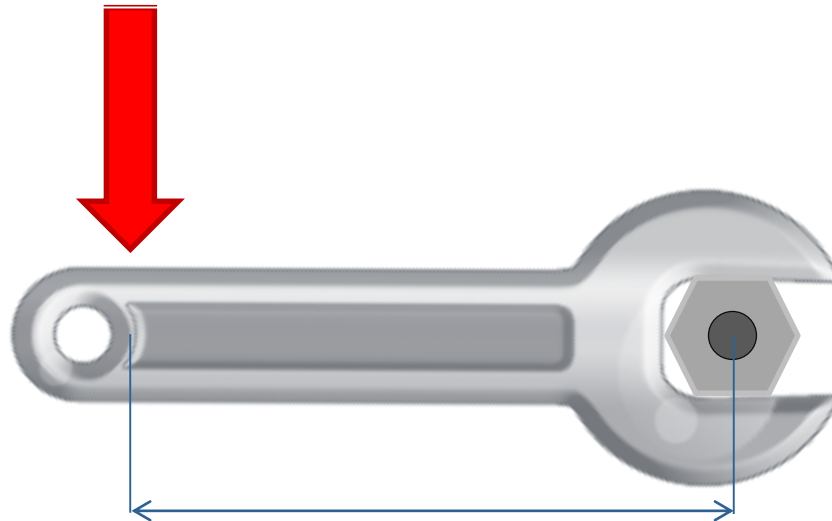

$$\text{Torque} = 1 \text{ Ft} \times 1 \text{ Lb} = 1 \text{ Ft-Lb}$$



# Motor Performance Characteristics

# Motor Performance Characteristics

- Basic Characteristics
  - › Speed / #Poles
  - › Horsepower
  - › Torque
  - › Speed Torque Curves
- Starting
- Efficiency
- Service Factor and Temperature

# Motor Speed

- The synchronous speed of an induction motor:

$$\text{RPM syn.} = \frac{120 \times \text{Hz}}{\# \text{ of poles}}$$

- The difference between the synchronous speed and the actual speed of the rotor is called “Slip”

Synchronous Speed (RPM)	# of Poles	Frequency (Hz)
3600	2	60
1800	4	60
1200	6	60
900	8	60
720	10	60

# Motor Horsepower

- The power output of a rotary electric motor is:

$$HP = \frac{RPM \times T}{5252}$$

- Where P is in horsepower (hp).
- RPM is the shaft speed in revolutions per minute
- T is the torque in foot pounds (lb-ft)
- 5252 is a constant

# Motor Speed Torque Curve

- A – Locked Rotor / Starting Torque
- B – Pull-up torque
- C – Breakdown Torque
- D – Full Load Torque
- E – Synchronous Speed

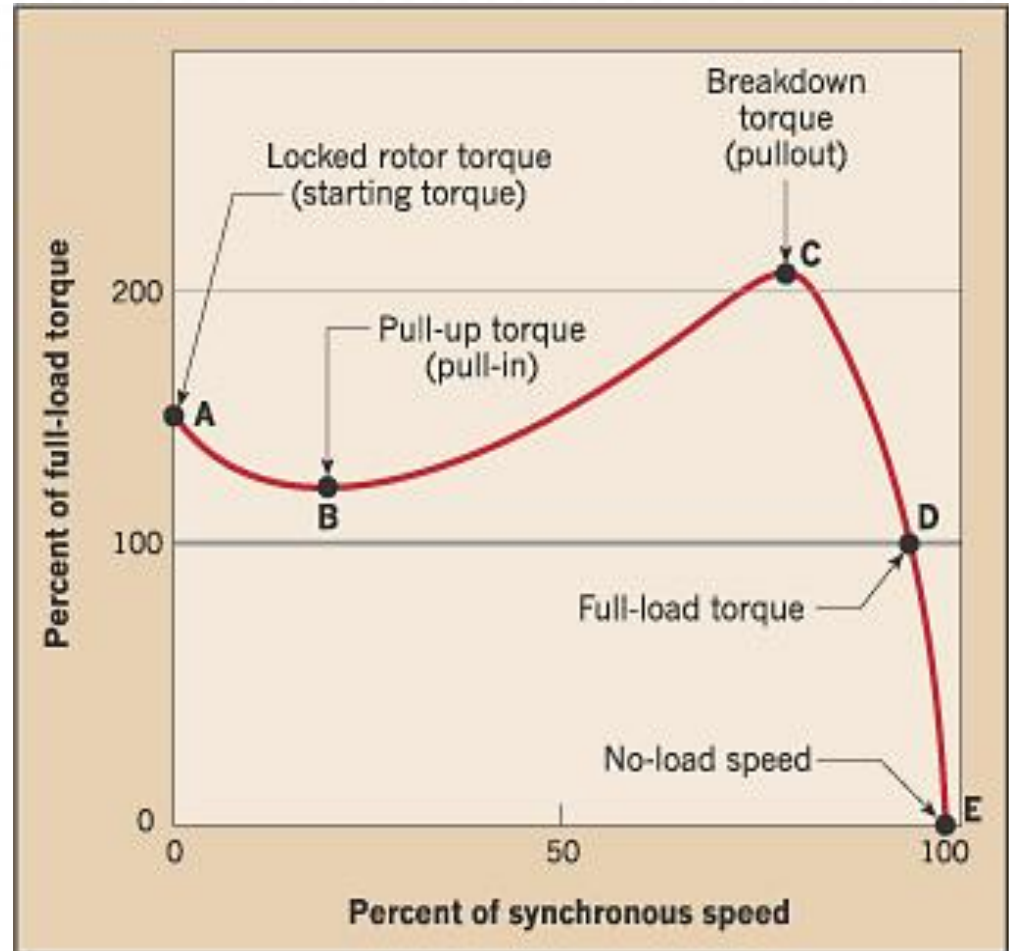

# Motor Designs

- The Material and Shape of the Rotor Bars Are the Main Factors in Obtaining Various Speed/Torque Curves
- NEMA Defines 4 Basic Types of Speed/Torque Characteristics for Induction Motors:
  - › **DESIGN A**
  - › **DESIGN B**
  - › **DESIGN C**
  - › **DESIGN D**
- The Stator Has Little to Do With the Shape of the Motor Speed/Torque Curve
- Different Rotors Could Be Used With the Same Stator to Change the Characteristic Shape

# Rotor Slot Designs

B

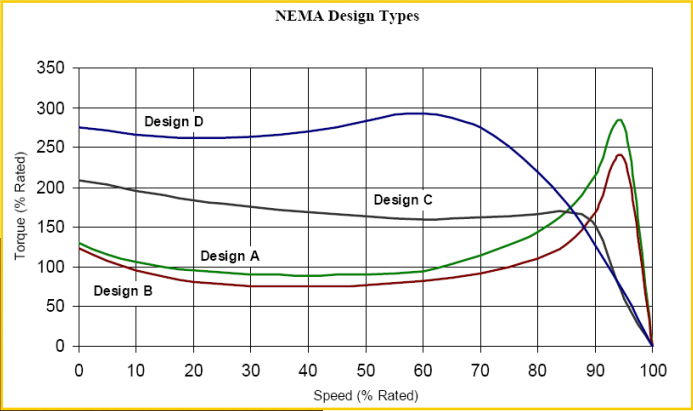
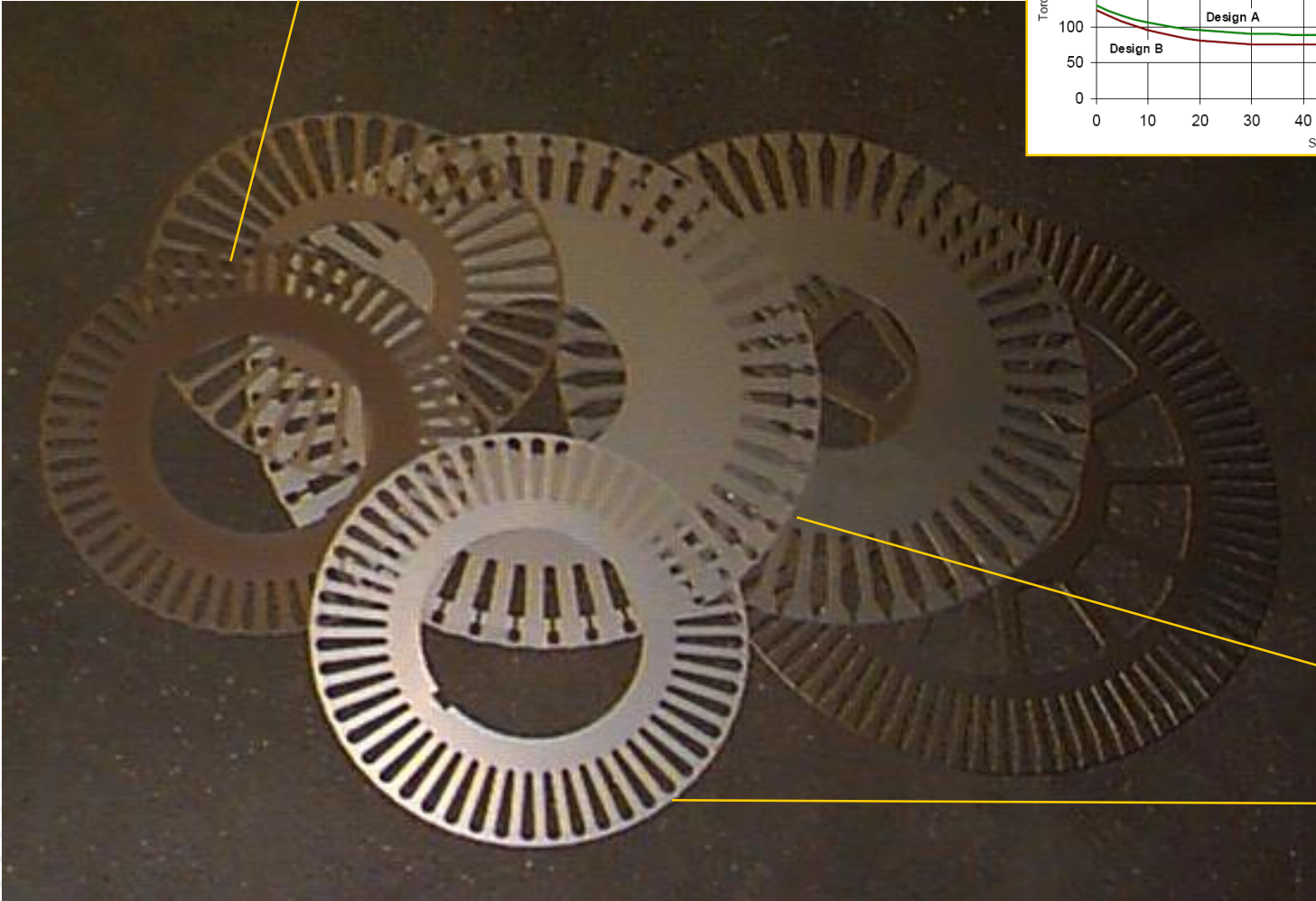

C

B

# Comparison of NEMA Designs

Comparison of NEMA Standard Design Motor Parameters

NEMA DESIGN	LOCKED TORQUE- % OF FULL LOAD TORQUE	ROTOR TORQUE- % OF FULL LOAD TORQUE	BREAKDOWN TORQUE- % OF FULL LOAD TORQUE	LOCKED CURRENT- % OF FULL LOAD CURRENT	ROTOR % OF FULL LOAD CURRENT	SLIP %	RELATIVE EFFICIENCY
A	70-275		175-200	600-1000		0.5-5	MED-HIGH
B	70-275		175-300	600-700		0.5-5	MED-HIGH
C	200-250		190-225	600-700		1-5	MEDIUM
D	275		275	600-700		5-25	LOW

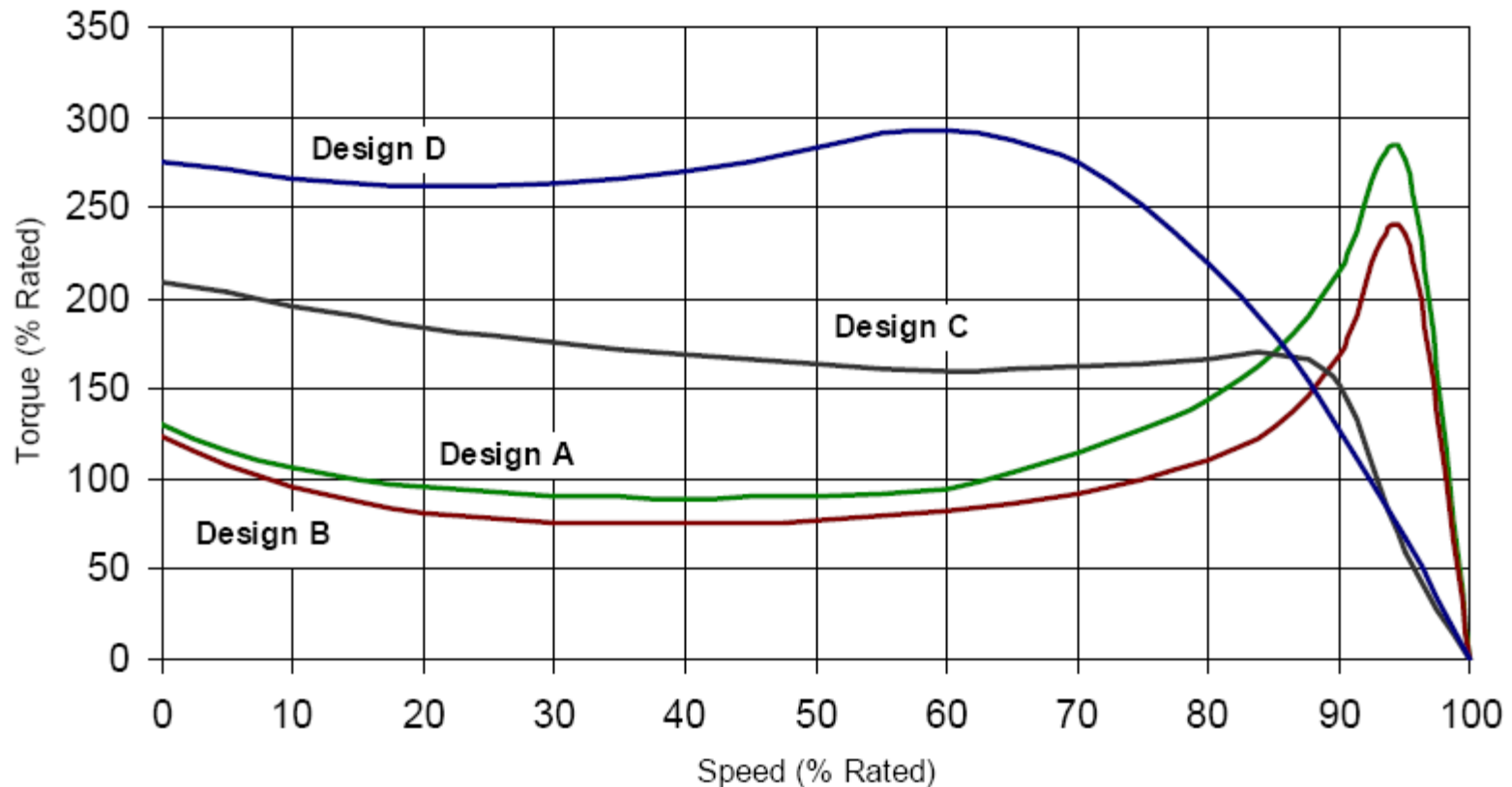



# Actual Speed Torque Curves

## Effect of Rotor Conductivity on the Same Electrical Design

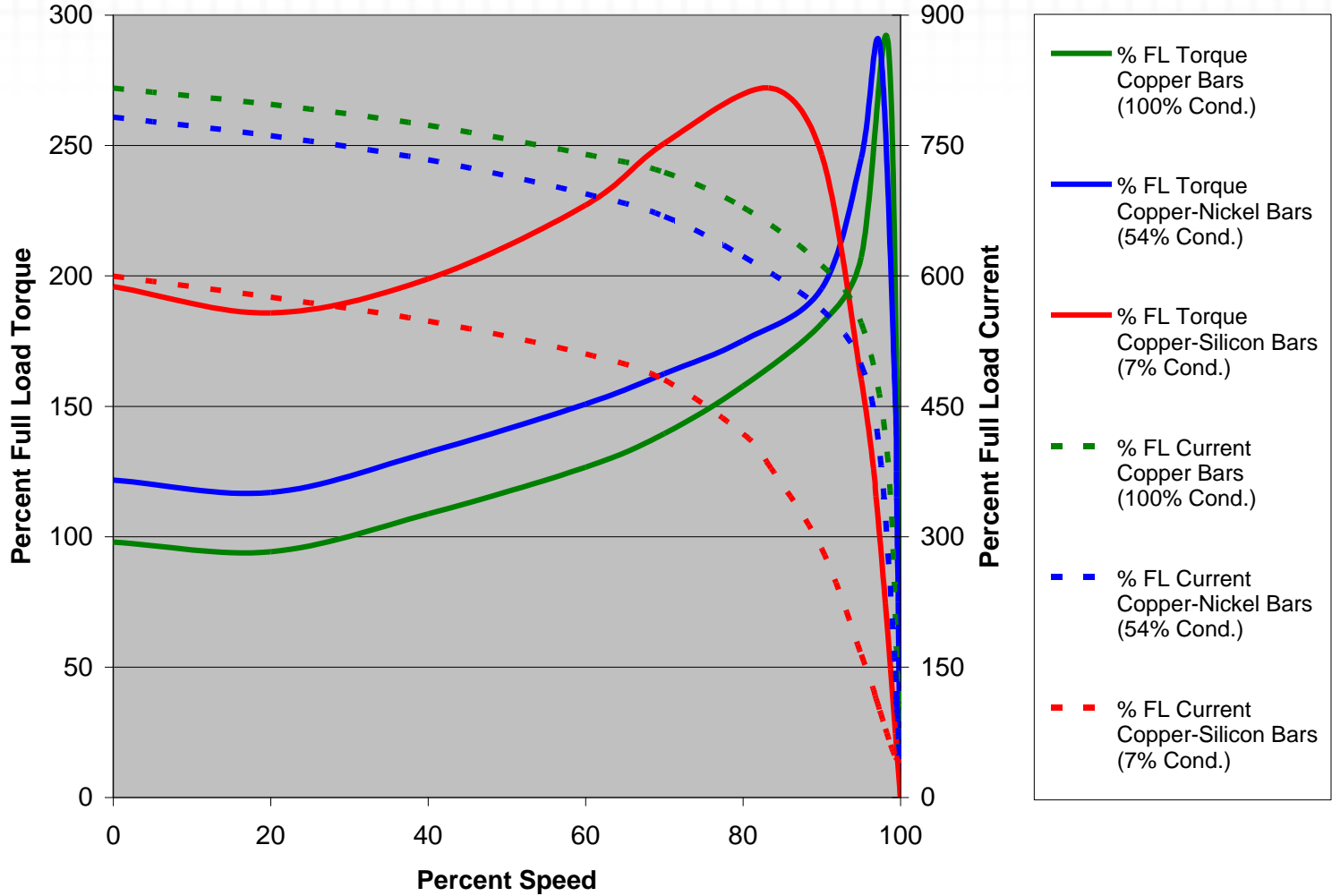

# Actual Speed/Torque Curves

- Why not go with 7% conductivity rotor bars for everything?
  - › PROS: High LRT, High BDT, Low LRA
- Rotor losses are significantly higher with 7% conductivity bars.
  - › CONS: Larger frame sizes, less efficiency
- Slip is significantly higher with 7% conductivity bars.
  - › CONS: Poor load speed regulation

# Actual Speed/Torque Curves

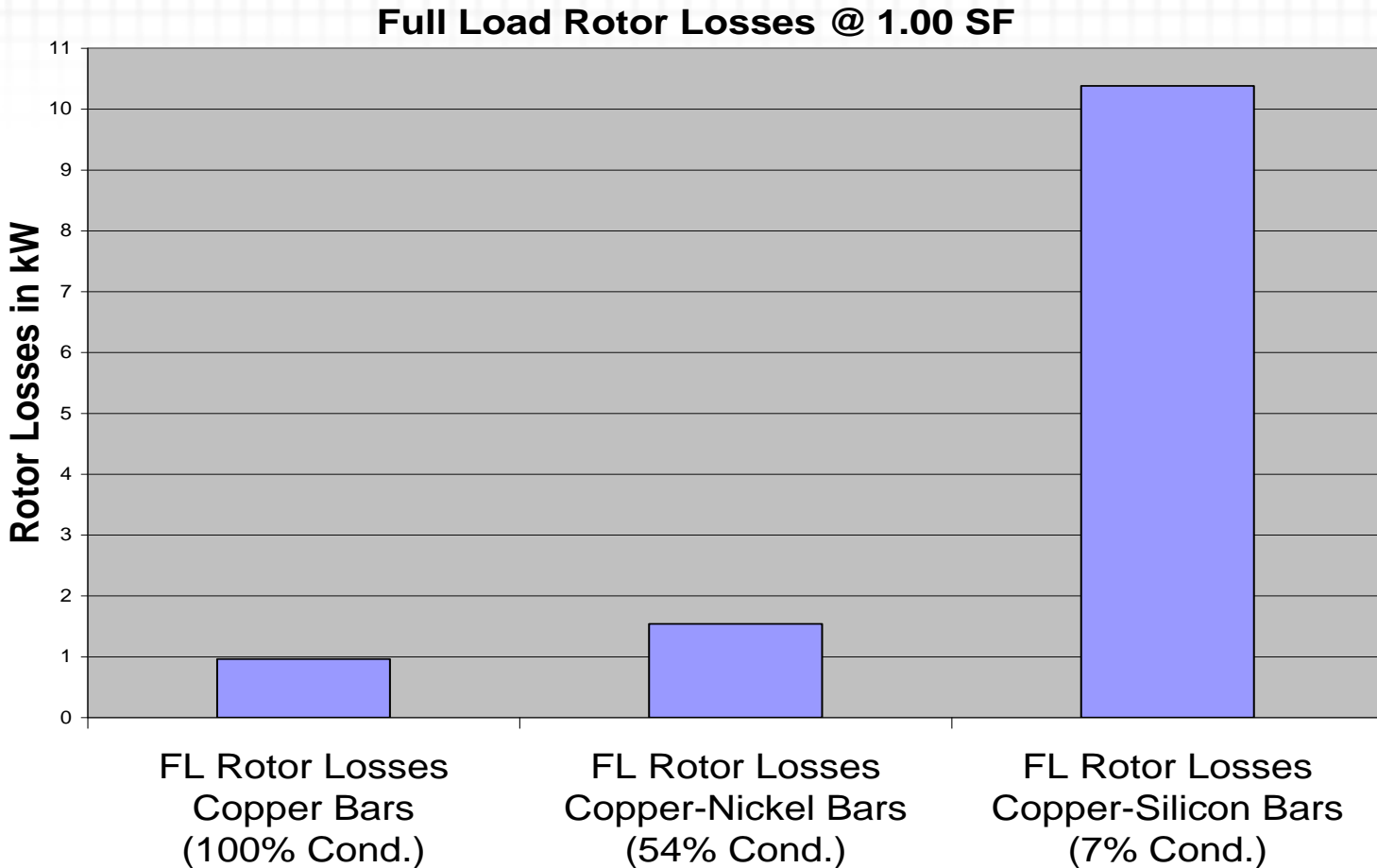

# Motor Starting

# Starting Method

## Why is this important?

- Fixed speed motors need to accelerate from zero to full speed.
- Torque is required to accelerate the motor.
- Accelerating torque is the difference between motor torque and load torque.
- Reducing the voltage available to the motor during start reduces the available torque and the amount of current that is required to start.
- The goal of most starting methods is to reduce starting current.
- Proper electrical design needs to provide for adequate starting as well as running characteristics.

# Torque and Current Formulas

- Current  $\propto$  Voltage
  - › Exponent is 1 to 1.1
    - $0.8^1 = 0.8 = 80\%$
    - $0.8^{1.1} = 0.78 = 78\%$
  - › At 80% Volts, Expect 78 – 80 % Current
  
- Torque  $\propto$  Voltage<sup>2</sup>
  - › Exponent is 2 to 2.2
    - $0.8^2 = 0.64 = 64\%$
    - $0.8^{2.2} = 0.61 = 61\%$
  - › At 80% Volts, expect 61-64 % Torque

# Importance of Load and Motor Curve Interaction

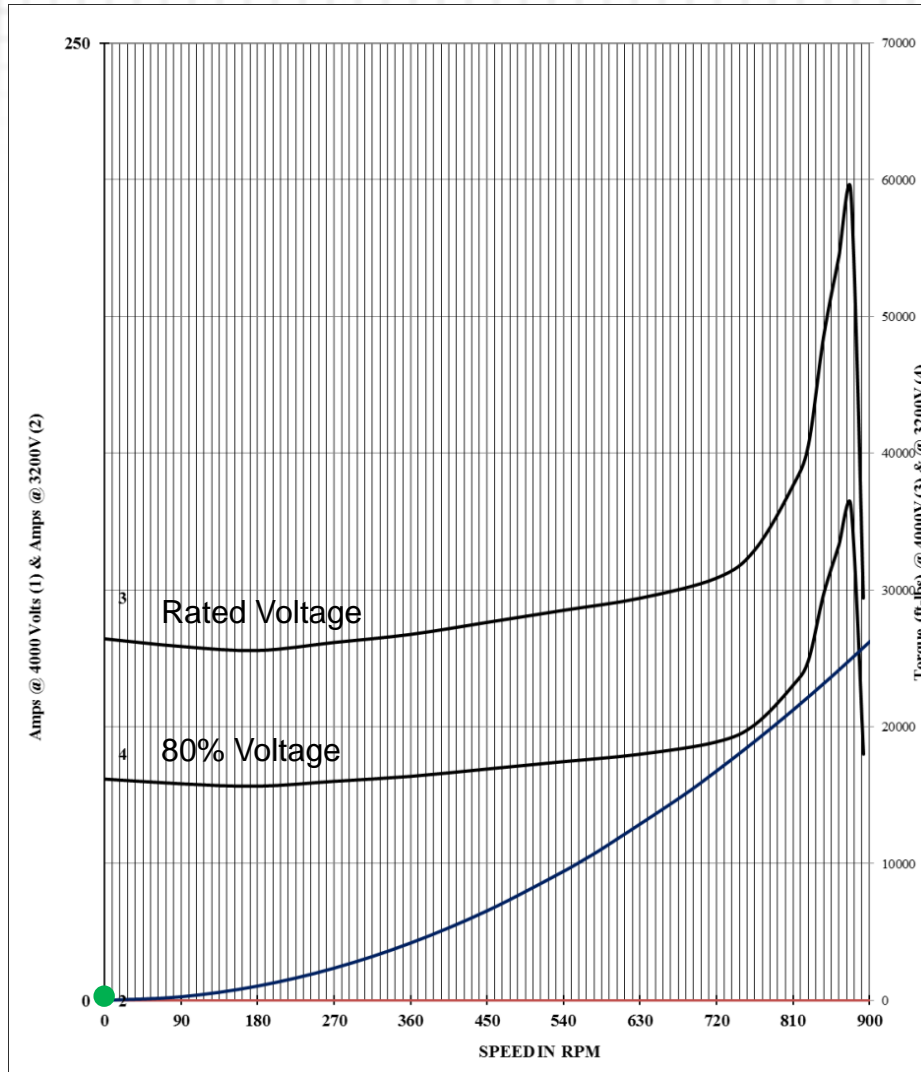

- 5000HP @ 900rpm motor (pump speed 127 RPM)
- Application: Centrifugal Pump
- “Standard” LAC motor design will start this load at 80% Voltage

# Importance of Load and Motor Curve Interaction

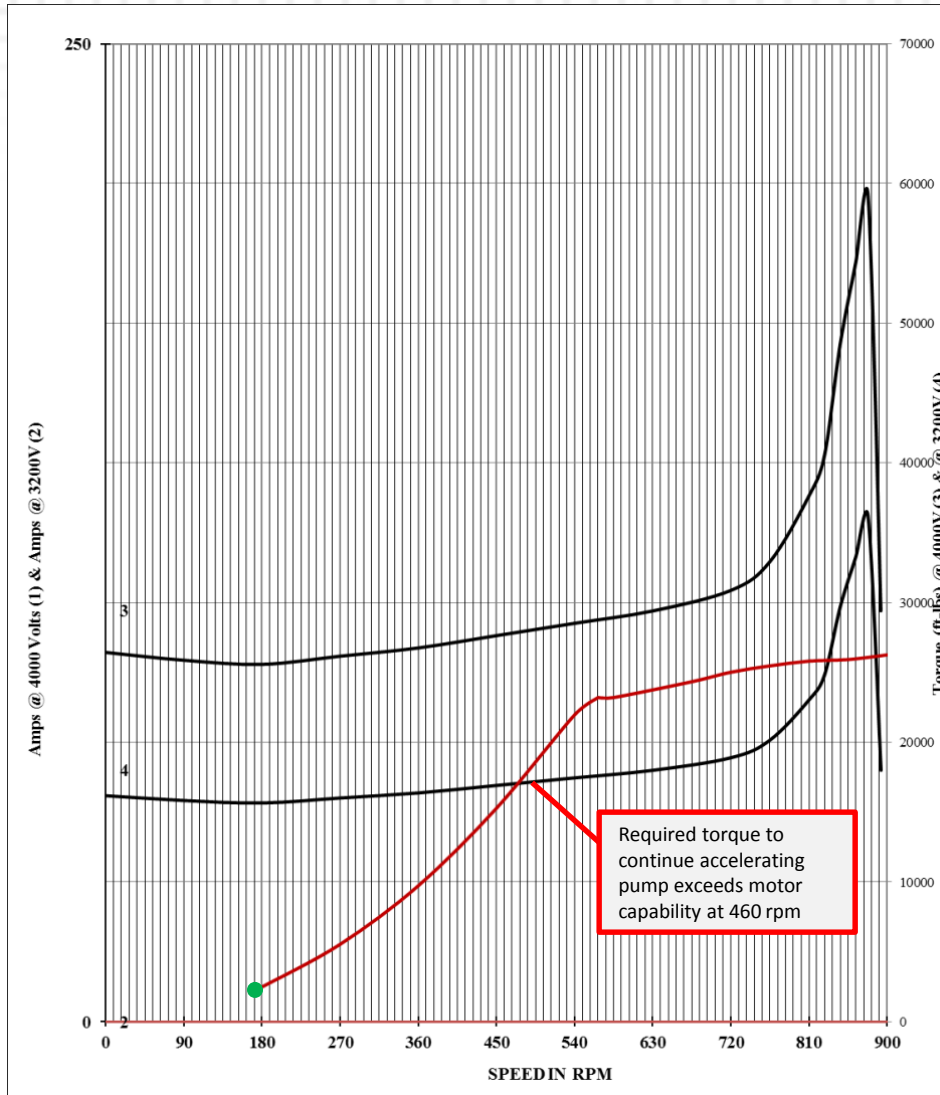

- Special load curve
- Much higher torque at lower speeds.
- “Standard” 5000 HP motor electrical design will not start this load



# Importance of Load and Motor Curve Interaction

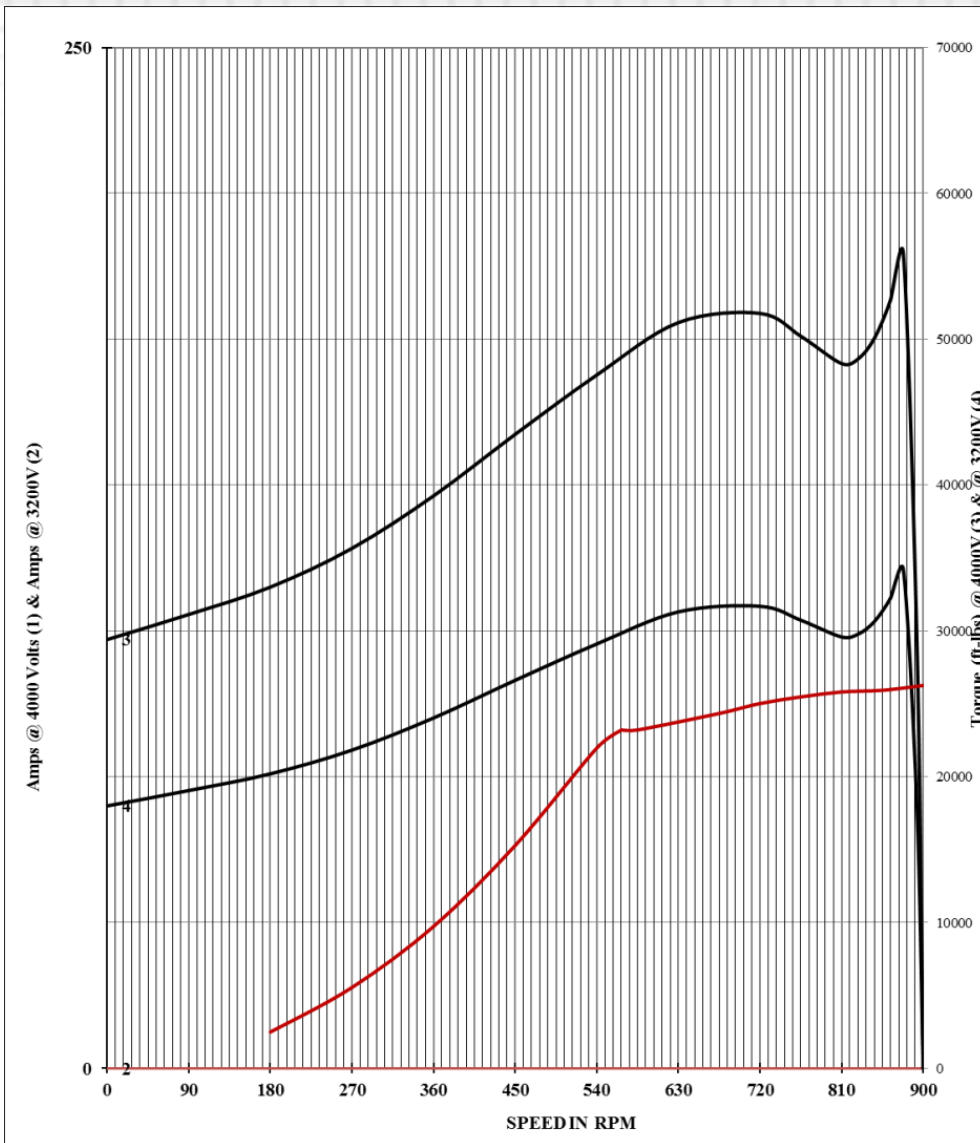

- If this new load curve is to be started across the line, we need more torque at lower speeds
  - › Requires different rotor bar design.

# LOAD CURVES

## Pump/Fan

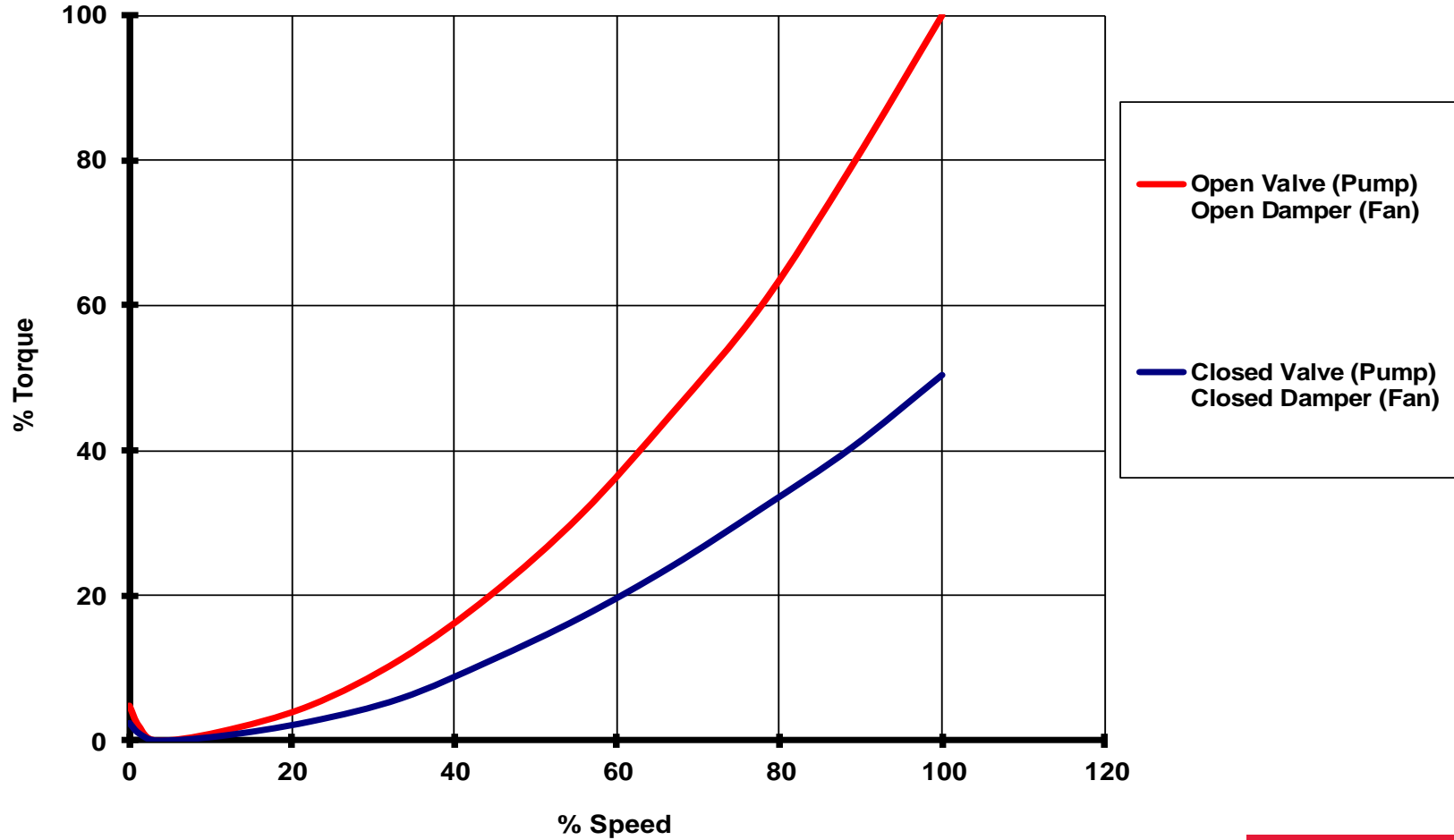

# LOAD CURVES

## Compressor

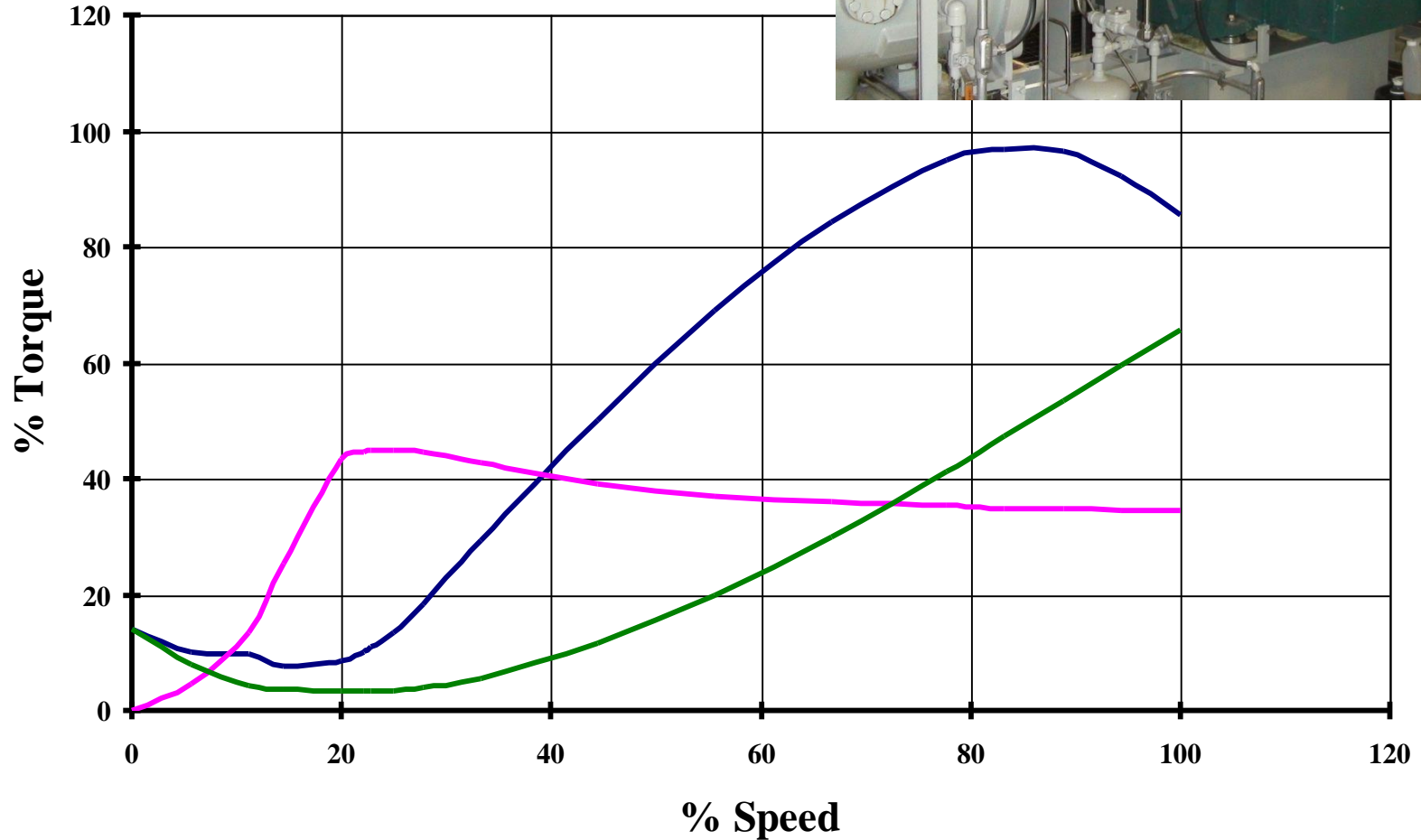

# Reciprocating Compressor Torque Effort Curve

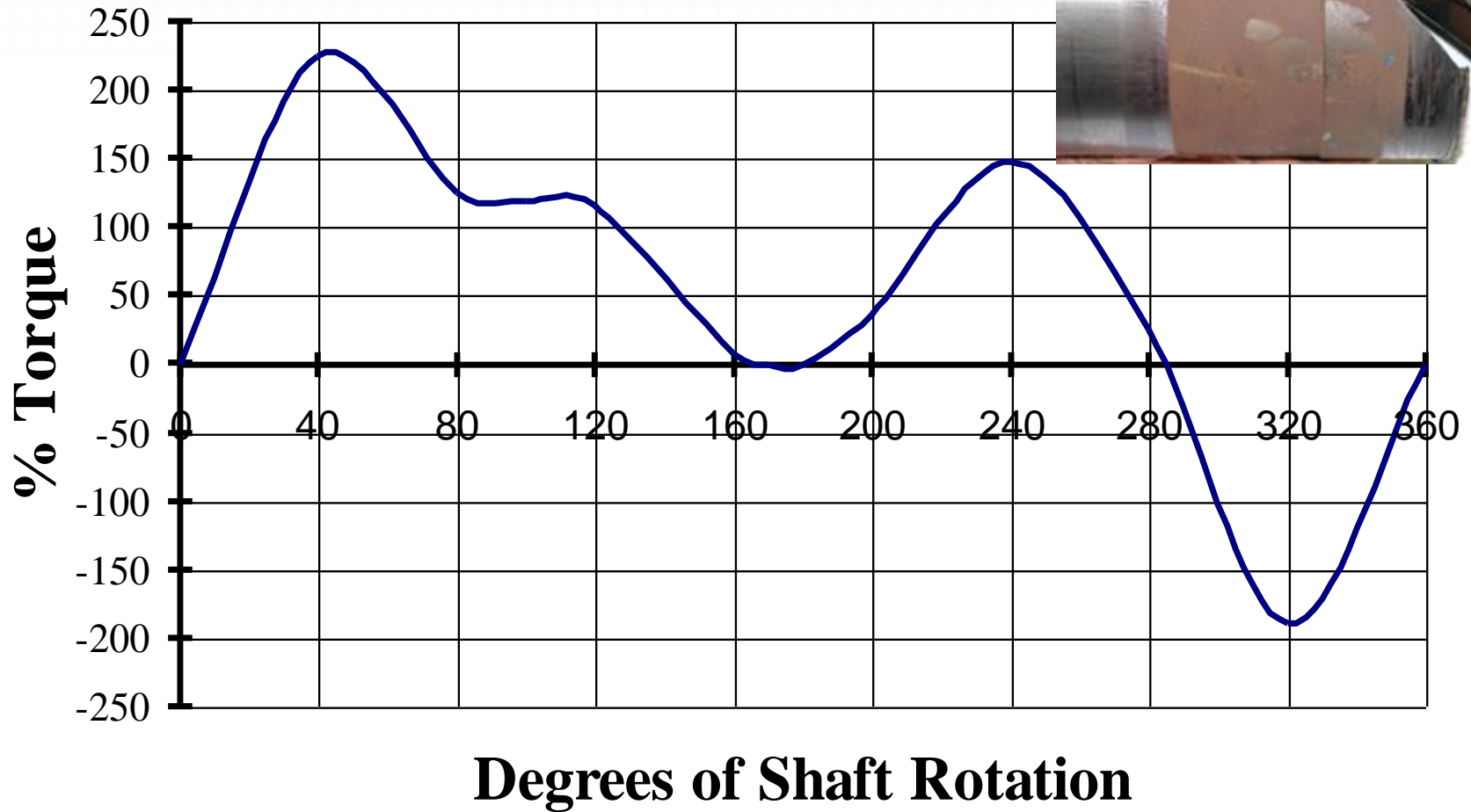

# LOAD CURVES

## Conveyor

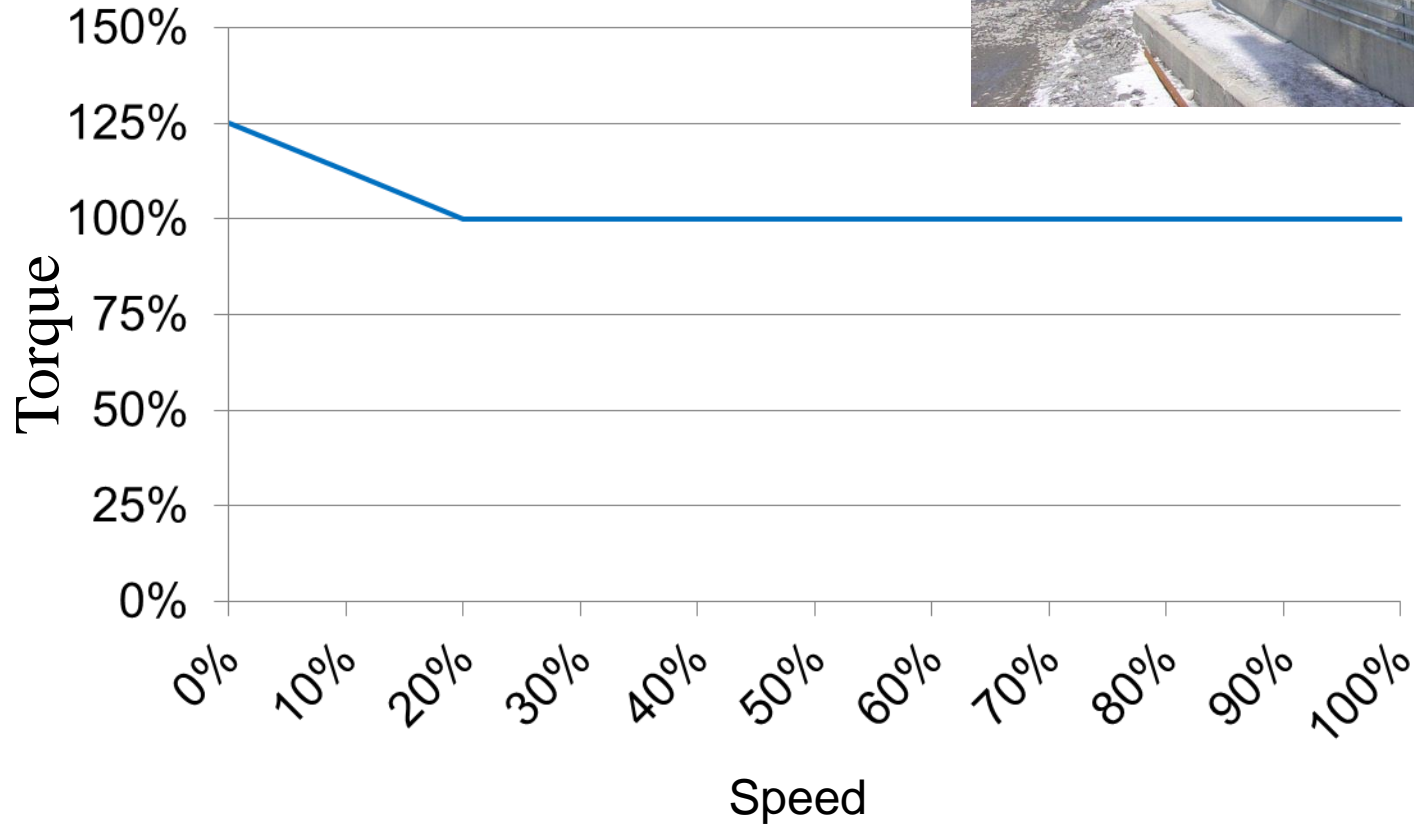

# Starting Method

- Full Voltage
- Auto Transformer / Voltage Dip
- Current Limiting Soft Start
- Adjustable Speed Drive



# Starting Method

## Reduced Voltage - NEMA Load Curve

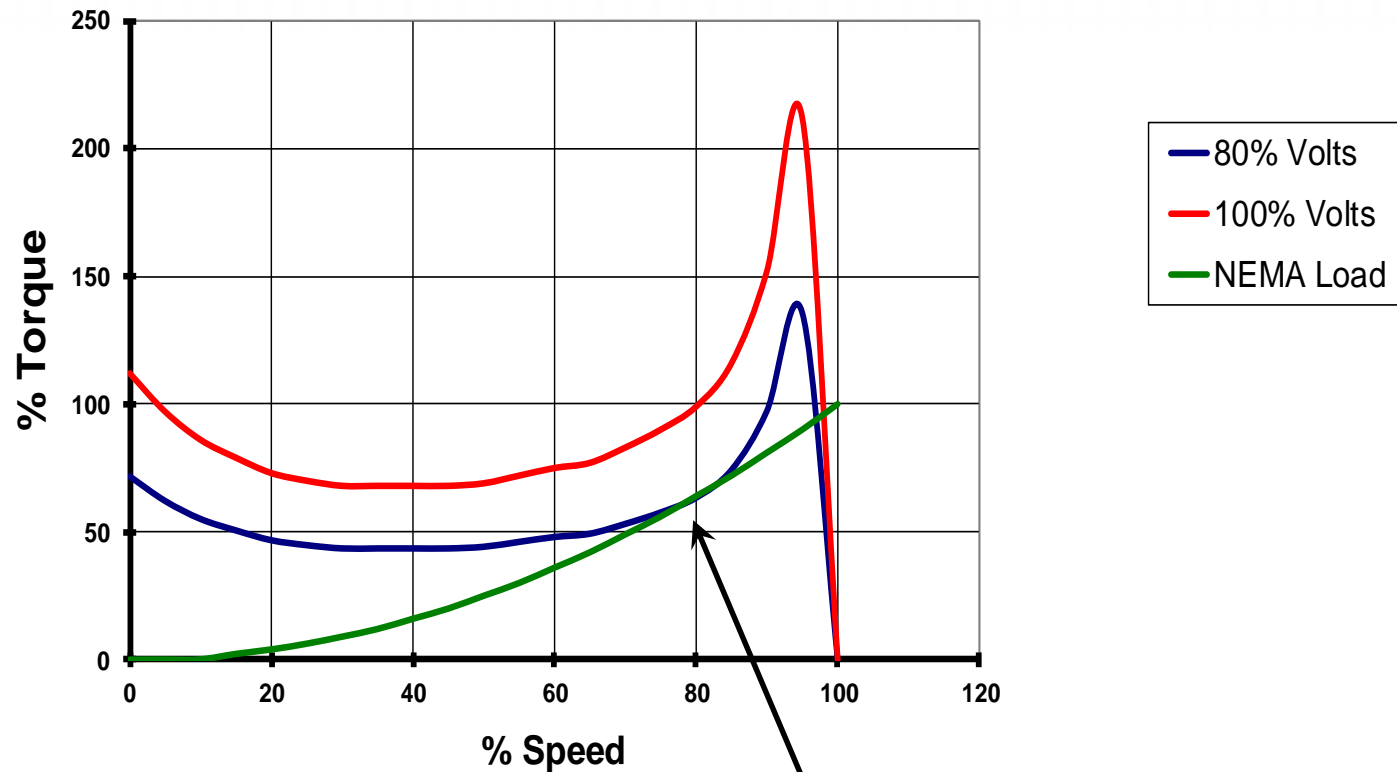

Is there anything wrong here?

Yes! Motor stalls at 80% speed under 80% RVS conditions.

# Starting Method

## Reduced Voltage - 50% NEMA Load Curve

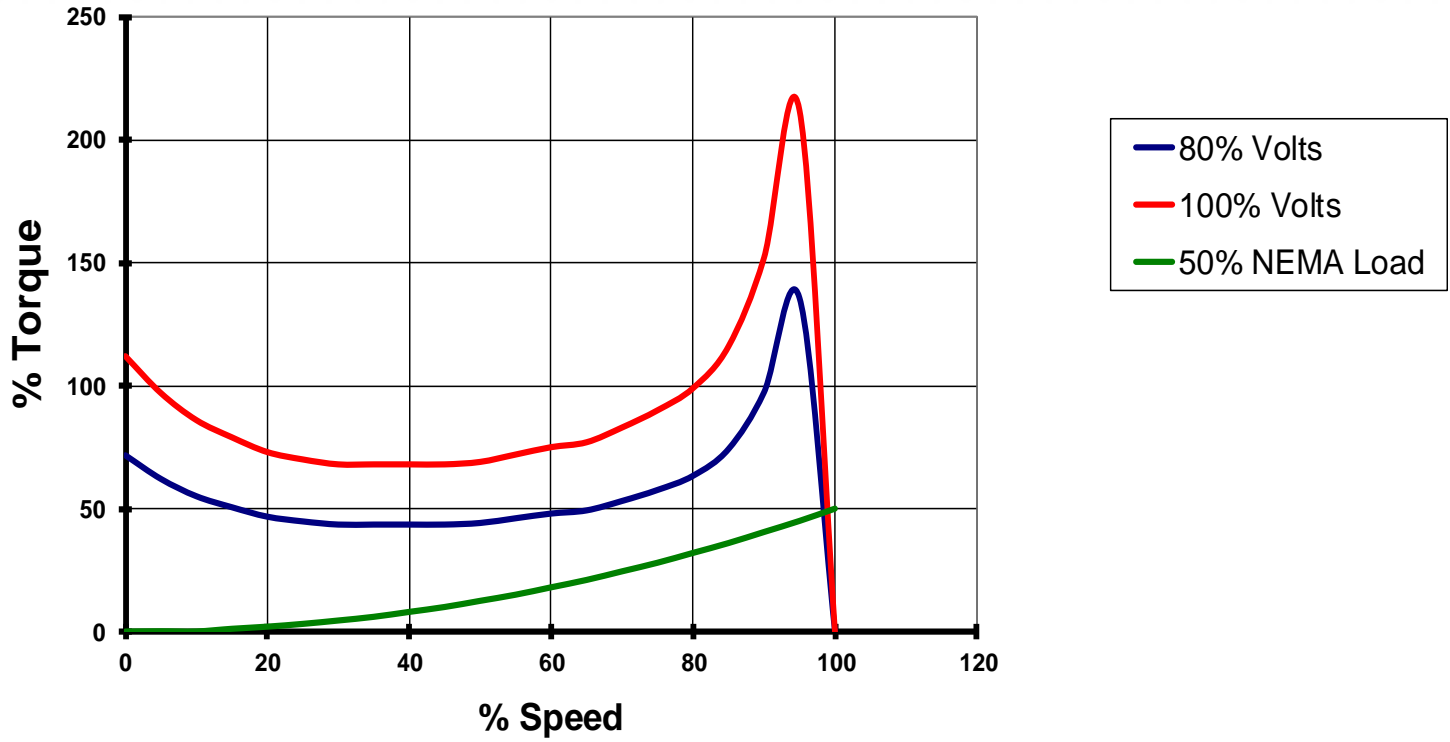

**Load has been reduced,  
motor can accelerate to full speed**



# Starting Method

## Wye Start - Delta Run

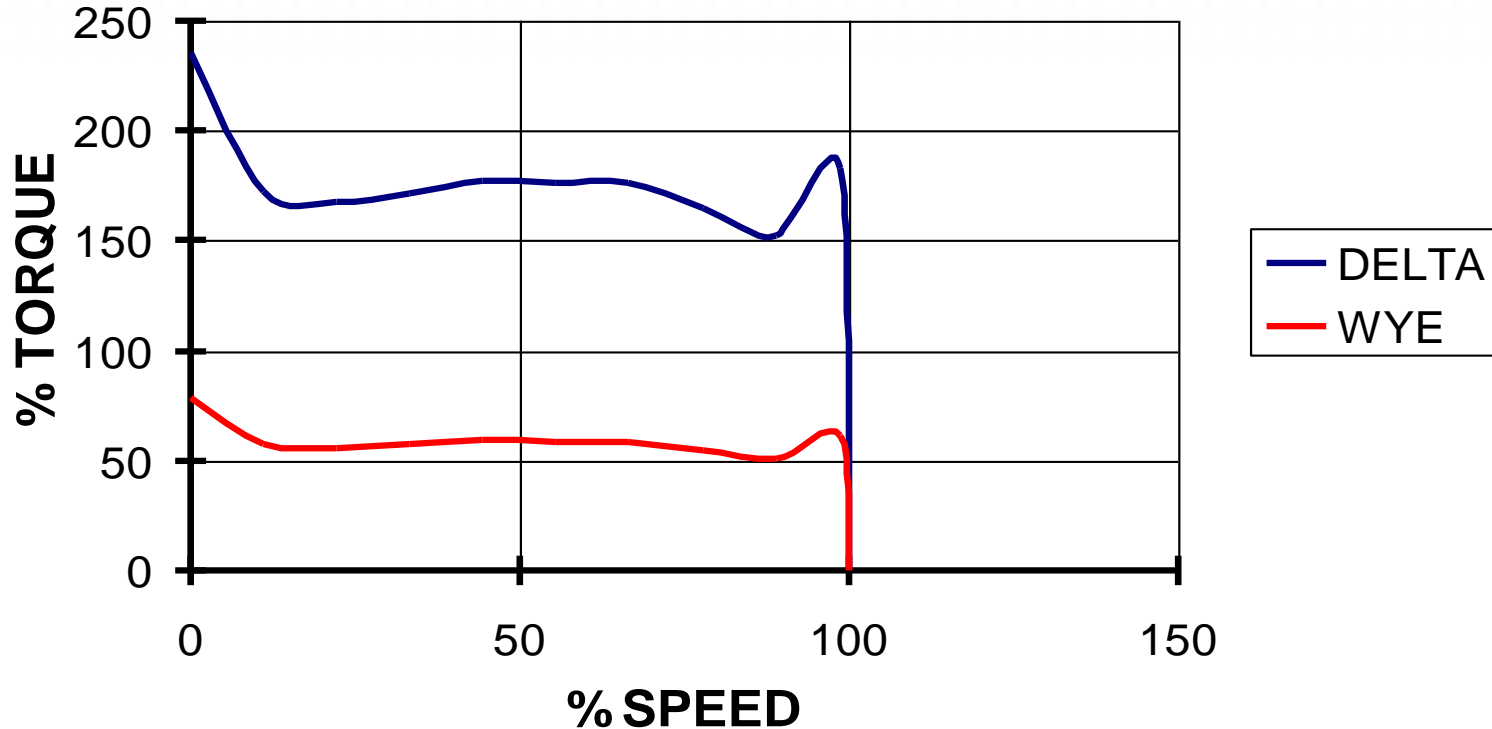

What is the starting voltage applied to the motor?

What does motor current do?

# Starting Method

## Wye Start - Delta Run

STANDARD 6 LEAD

Y START – DELTA RUN

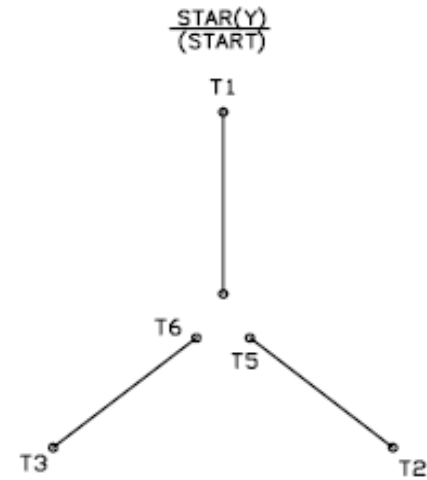
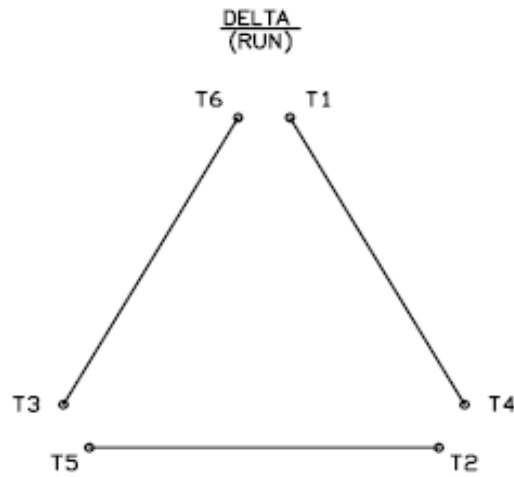

# Starting Methods

## Current Limiting Soft-Start (250% FLA)

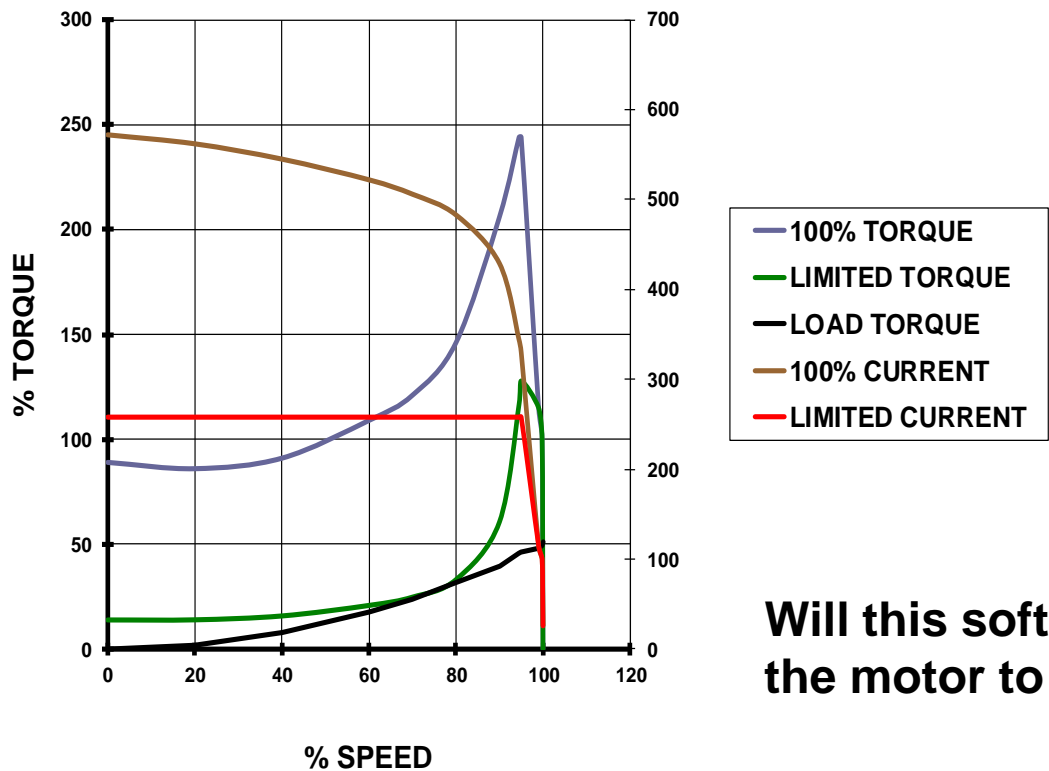

**Will this soft-start accelerate the motor to full load speed?**

# Starting Methods

## Variable Frequency Drive

- Motor operates in the range from 0-100% torque continuously
- Motor operates from 110%-150% torque intermittently
- Current is proportional to load
- No high starting current

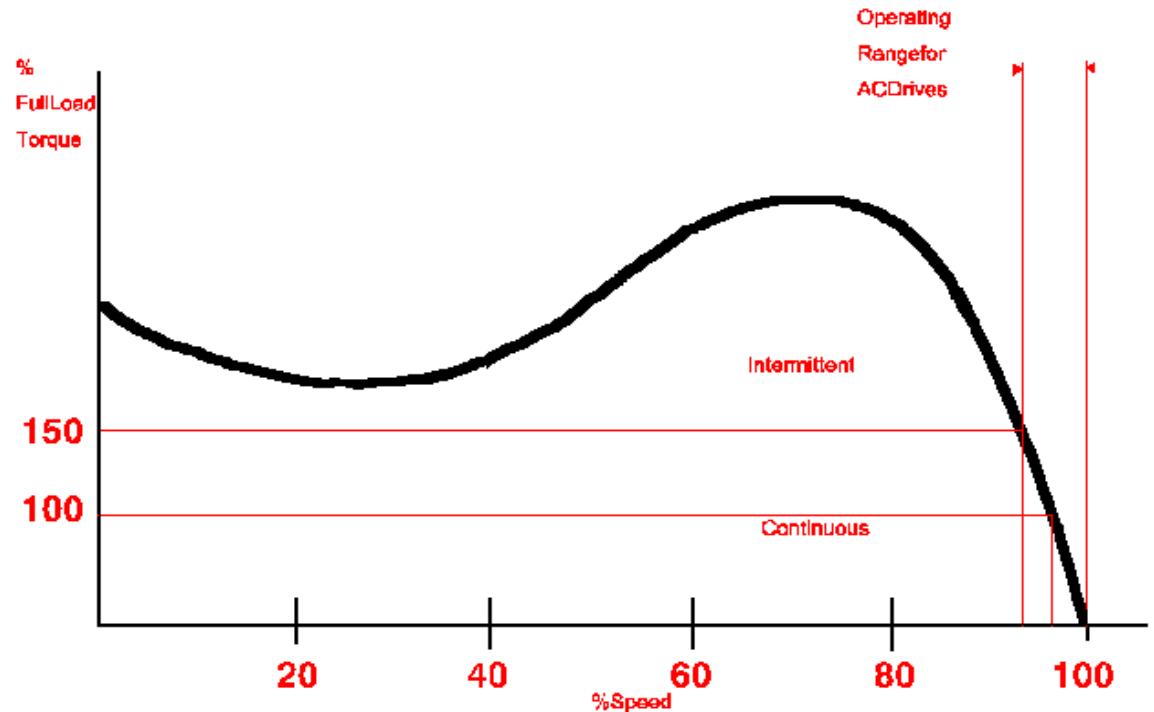

# Starting Methods

## Variable Frequency Drive

Variable Frequency: As the frequency changes, the speed torque curve is shifted. The motor always operates on the right side of the curve.

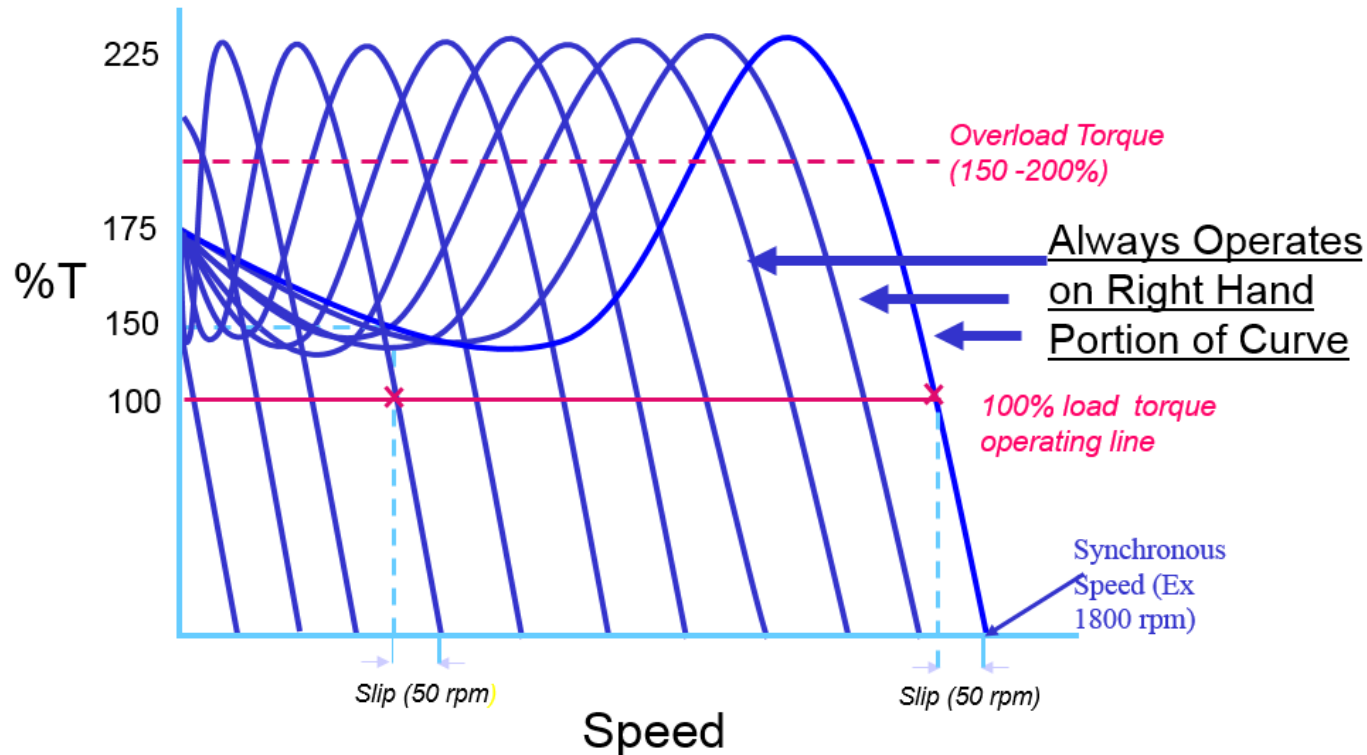

# Motor Efficiency

# Motor Efficiency

- **Almost 30% of all electricity generated in the United States is used to run electric motors.<sup>(1)</sup>**
- **For industrial companies, electric motor-driven systems consume 63% of the electricity used. <sup>(1)</sup>**
- **The cost of electricity to run an electric motor represents over 97% of its lifetime cost.**

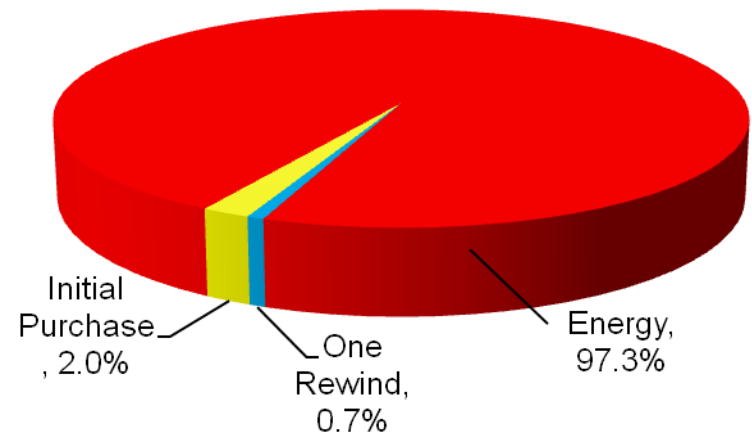

**Lifetime Cost of a Motor**

<sup>(1)</sup> Department of Energy - Market Opportunities Assessment 2002

# Energy Cost

- Cost of 100 hp motor around \$5000
- Energy cost is about \$0.07/kW-hr
- Cost to run the motor for one day

$$100 \text{ hp} * 0.746 \text{ kW/hp} * 0.07 \text{ \$/kW-hr} * 24 \text{ hrs} =$$

**\$125/day**

# of days for energy cost = purchase price?

**40 Days!**



# Induction Motors

- Workhorse of Industrial and Commercial Applications
- Motor efficiency regulated by US DOE, Canada - NRCAN, EU
  - › EPA Act effective 1997
  - › EISA effective 2010
  - › **Integral Motor Rule effective 12-2015 or 6-2016**
  - › **Small Motor Rule effective 3-2015**

# New: Integral HP Motor Rule

- Replaces Energy Independence & Security Act of 2007
- Expected to take effect 24 months after Final Rule (~May 2016)
- Most motors will be covered at Premium Efficiency levels (IE3)

# Compare IHP Rule to EISA

Motor Type	EISA	New Integral HP Rule
1-200 HP Subtype I	Premium Efficient NEMA MG 1, Table 12-12	Premium Efficient NEMA MG 1, Table 12-12
1-200 HP Subtype II	Energy Efficient NEMA MG 1, Table 12-11	Premium Efficient NEMA MG 1, Table 12-12
201-500 HP	Energy Efficient NEMA MG 1, Table 12-11	Premium Efficient NEMA MG 1, Table 12-12
56 Frame Enclosed	Exempt	Premium Efficient NEMA MG 1, Table 12-12
Custom Configurations	Exempt	Premium Efficient NEMA MG 1, Table 12-12
1-200 HP Fire Pump Motors	Energy Efficient NEMA MG 1, Table 12-11	Energy Efficient NEMA MG 1, Table 12-11

# Motors covered under IHP Rule

The motors regulated under expanded scope meet the following nine characteristics:

1. Is a single speed motor
2. Is rated for continuous duty
3. Squirrel cage rotor
4. 3-Phase line power
5. Has 2-, 4-, 6-, or 8-pole configuration
6. Is rated 600 volts or less
7. Has a three or four-digit NEMA frame size (or IEC metric equivalent) or an enclosed 56 NEMA frame size (or IEC metric equivalent)
8. 1 – 500 HP
9. NEMA design A, B or C or IEC design N or H electric motor

# Motors added previously not covered by EISA

- What is covered:
  - › NEMA Design A motors from 201-500 HP
  - › Electric motors with moisture-resistant windings, sealed or encapsulated windings
  - › Partial electric motors
  - › Totally-enclosed non-ventilated (TENV) electric motors
  - › Immersible electric motors
  - › Integral brake electric motors
  - › Non-integral electric brake motors
  - › Electric motors with non-standard endshields or flanges
  - › Electric motors with non-standard base or mounting feet
  - › Electric motors with special shafts
  - › Vertical hollow shaft electric motors
  - › Vertical medium and high thrust solid shaft electric motors
  - › Electric motors with sleeve bearings
  - › Electric motors with thrust bearings

# Motors not covered under IHP rule

- What is not covered:
  - › Single phase motors (Small Motor Rule)
  - › DC motors
  - › Two digit frames (42 – 48)
  - › Multi-speed motors
  - › Medium voltage motors
  - › TEAO motors
  - › Submersible motors
  - › Water-cooled motors
  - › Intermittent duty motors
  - › Stator-rotor sets
  - › Design D motors

# New: Small Motor Rule

- Passed in 2010
- Covers ¼ - 3 HP 2, 4, 6 pole
- Open Drip Proof – General Purpose only
- 42, 48 , 56 Frame
- Both Single and Three Phase
- Specific DOE Average Efficiency Assignments (Not NEMA nominal)
- Effective March 9, 2015

# Motor Efficiency and Losses

$$\text{Motor Efficiency} = \frac{\text{Output}}{\text{Input}} = \frac{\text{Input} - \text{Losses}}{\text{Input}} = \frac{\text{Shaft Power Out}}{\text{Electrical Power In}}$$

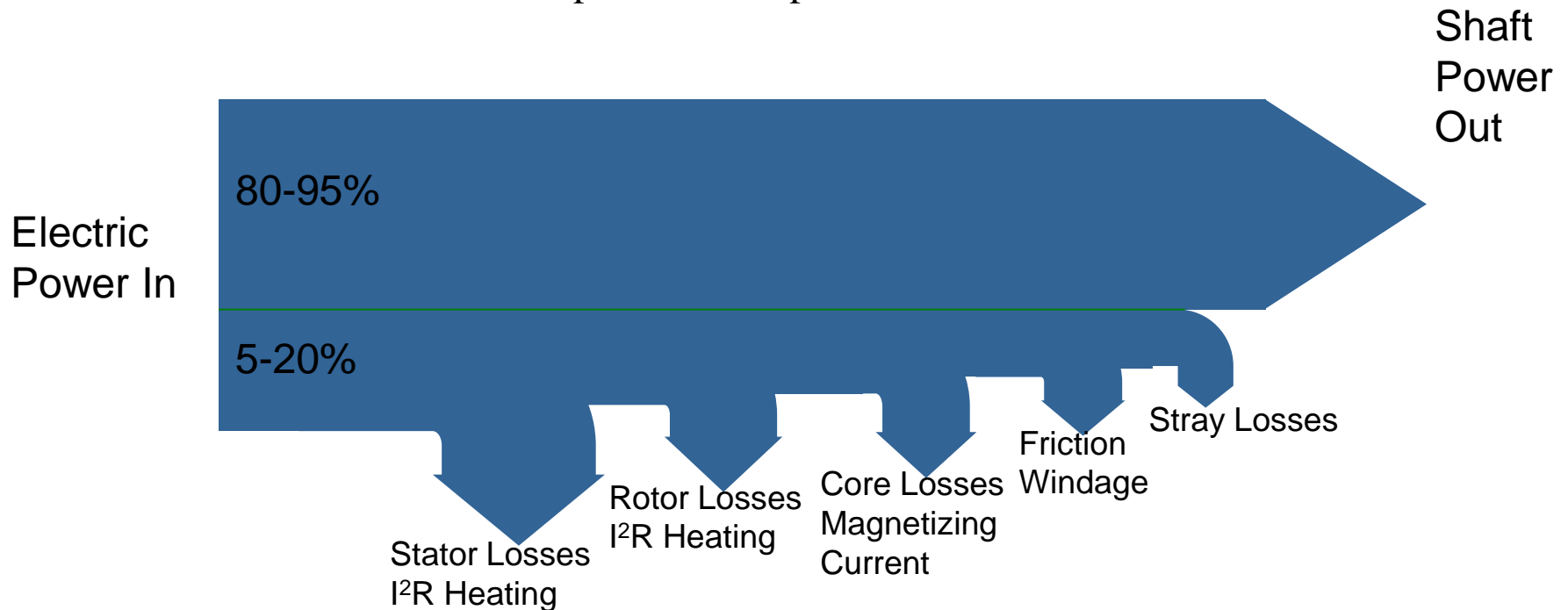



# Energy Efficient Motor Design

- Additional active material
  - › Winding (copper)
  - › Rotor core
  - › Stator core
- Improved electrical steel
- Thinner laminations
- Fan design (low loss)
- Manufacturing processes - quality assured
- Optimized material utilization - experience design

Older Motor --- very thick stator laminations

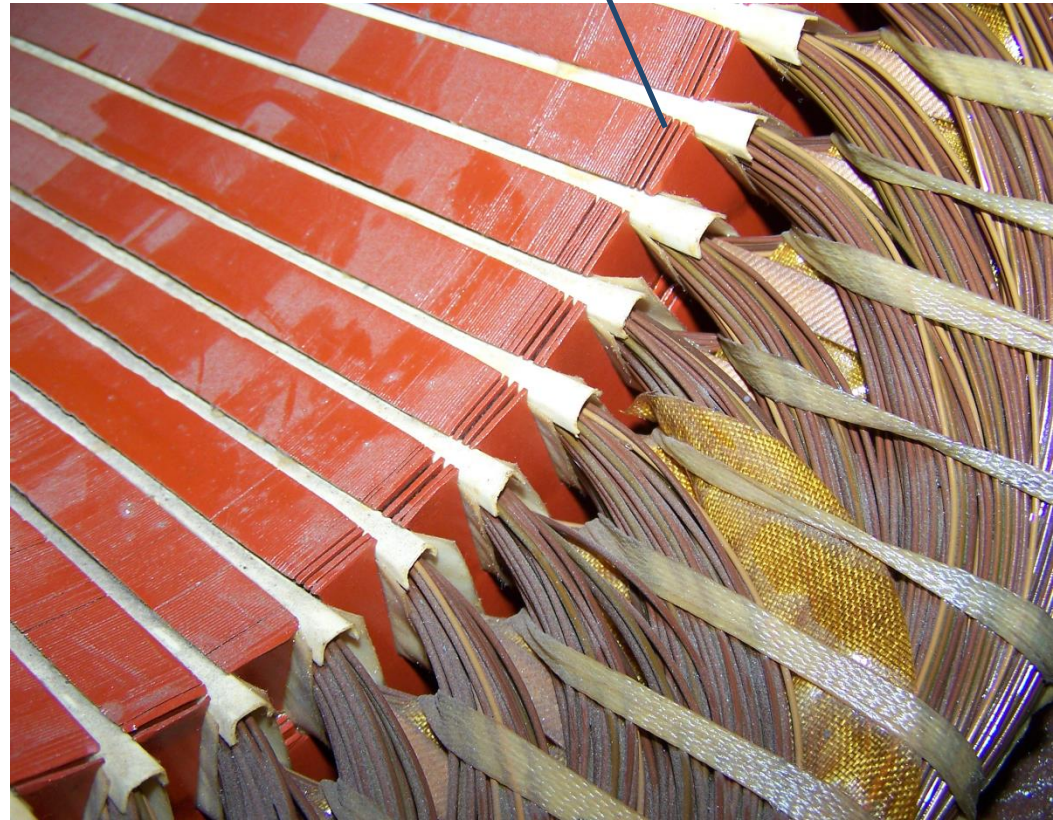

# Reduction of Losses

- Losses in an A-C motor & how to reduce them
  - › Core loss - better magnet steel - longer stack - thinner laminations
  - › Stator  $I^2R$  loss - larger diameter wire
  - › Rotor  $I^2R$  loss - larger diameter rotor bars
  - › Mechanical loss - smaller fans & better lubrication system for bearings
  - › Stray load loss - better manufacturing tolerances

# Rotor General Comparison

150 HP

1800 RPM

445 T Frame

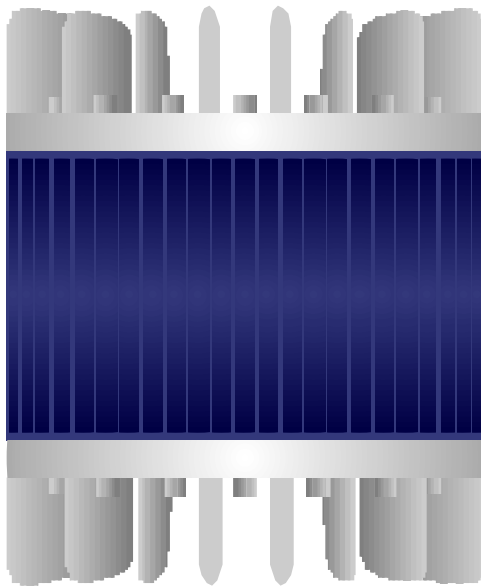

**Standard**

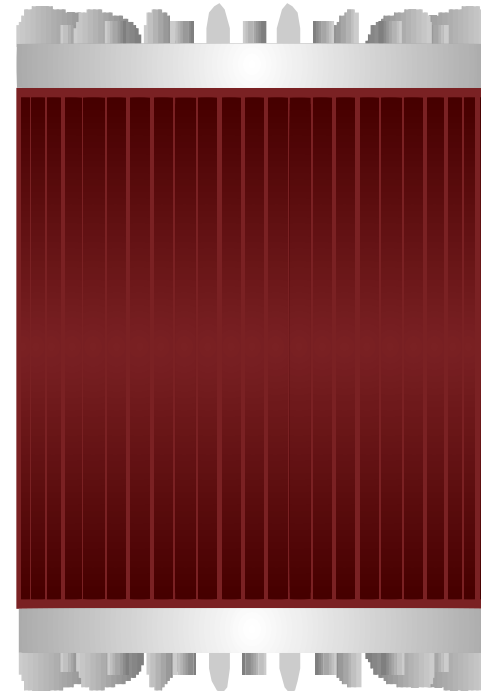

**High**

~15% more material

# “Right-size” the Motor

- Choose the correct rating for the application
  - › Oversized motors have lower efficiency and power factor
  - › Highest efficiency 75 - 100% of rated load
  - › Service factor is for short-term operation

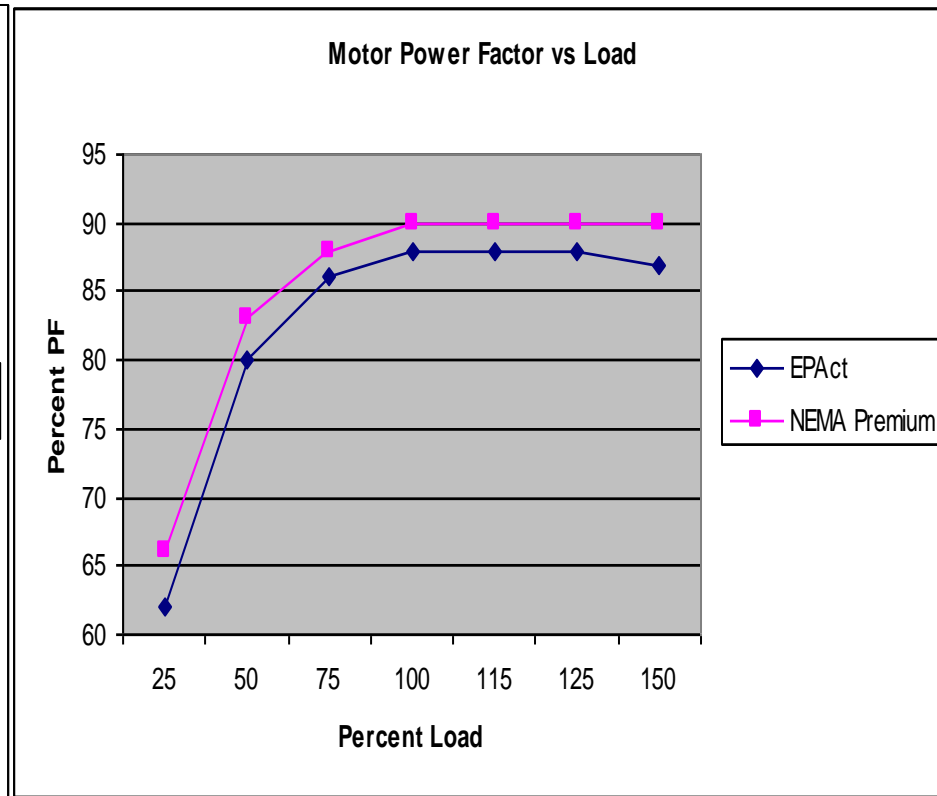
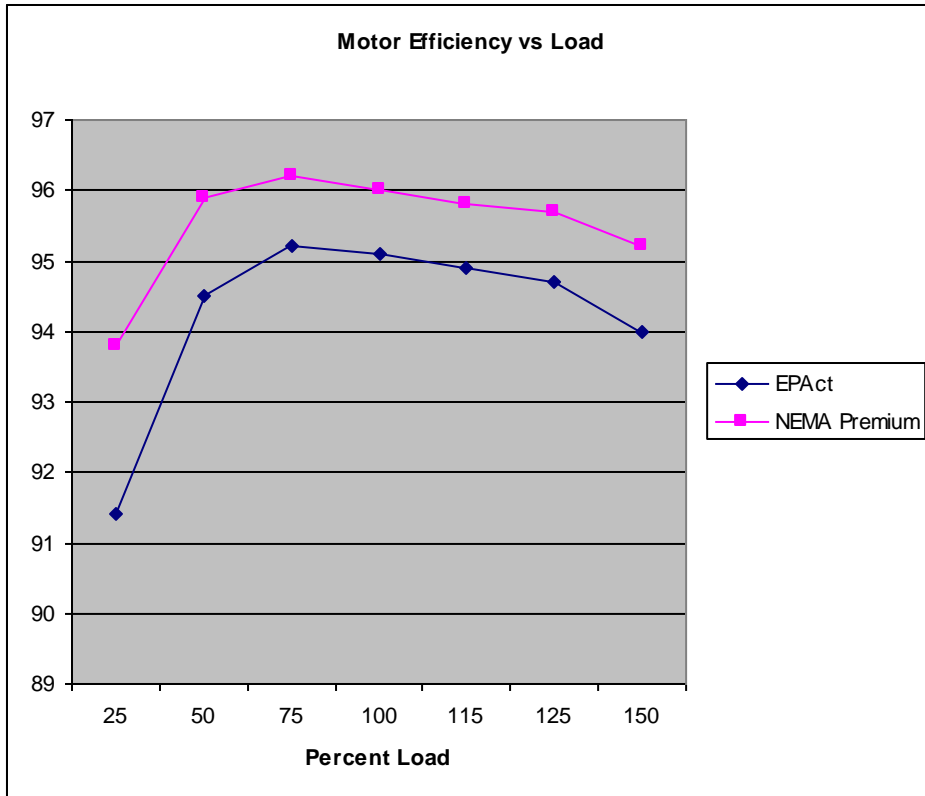

# Motor Service Factor and Temperatures

# Temperature Effect on Motor Life

## ■ Insulation life

- › Heat is the #1 cause of reduced insulation life
- › Winding insulation is rated according to its thermal capability
- › For every 10<sup>0</sup> C above rated temperature, motor life is reduced by 50%
- › For every 10<sup>0</sup> C below rated temperature, motor life increases by 2X
- › Common sources of overheating
  - Overload
  - Inadequate ventilation
  - Dirt buildup
  - Phase unbalance
  - High/Low voltage

## ■ Bearing life

- › Bearing temperatures are typically 50-75% of winding temperature
- › Temperature impact (+ 10<sup>0</sup> C = 50% life)

# Insulation Class

- B, F, or H
  - › Refers to total temperature the Insulation System is designed to withstand.
  - › Class B: 130°C
    - The 'previous' NEMA standard
  - › Class F: 155°C
    - Most common insulation class for current AC motors
  - › Class H: 180°C
    - High Ambient
    - Power Density
- Many motors today are designed with a Class F insulation system but operate at a Class B temperature rise.
  - › Results in longer insulation service life.

# Temperature Rise per NEMA MG1-2011

## 20.8.1 Machines with a 1.0 Service Factor at Rated Load

Item	Machine Part	Method of Temperature Determination	Temperature Rise, Degrees C			
			Class of Insulation System			
			A	B	F	H
a	Insulated windings					
	1. All horsepower (kW) ratings	Resistance	60	80	105	125
	2. 1500 horsepower and less	Embedded detector*	70	90	115	140
	3. Over 1500 horsepower (1120 kW)					
	a) 7000 volts and less	Embedded detector*	65	85	110	135
	b) Over 7000 volts	Embedded detector*	60	80	105	125
b	The temperatures attained by cores, squirrel-cage windings, collector rings, and miscellaneous parts (such as brushholders and brushes, etc.) shall not injure the insulation or the machine in any respect.					

## 20.8.2 Machines with a 1.15 Service Factor at Service Factor Load

Item	Machine Part	Method of Temperature Determination	Temperature Rise, Degrees C			
			Class of Insulation System			
			A	B	F	H
a	Insulated windings					
	1. All horsepower (kW) ratings	Resistance	70	90	115	135
	2. 1500 horsepower and less	Embedded detector*	80	100	125	150
	3. Over 1500 horsepower (1120 kW)					
	a) 7000 volts and less	Embedded detector*	75	95	120	145
	b) Over 7000 volts	Embedded detector*	70	90	115	135
b	The temperatures attained by cores, squirrel-cage windings, collector rings, and miscellaneous parts (such as brushholders and brushes, etc.) shall not injure the insulation or the machine in any respect.					

\*Embedded detectors are located within the slot of the machine and can be either resistance elements or thermocouples. For machines equipped with embedded detectors, this method shall be used to demonstrate conformity with the standard. (See 20.27.)



# Temperature Rise & Insulation Class Summary

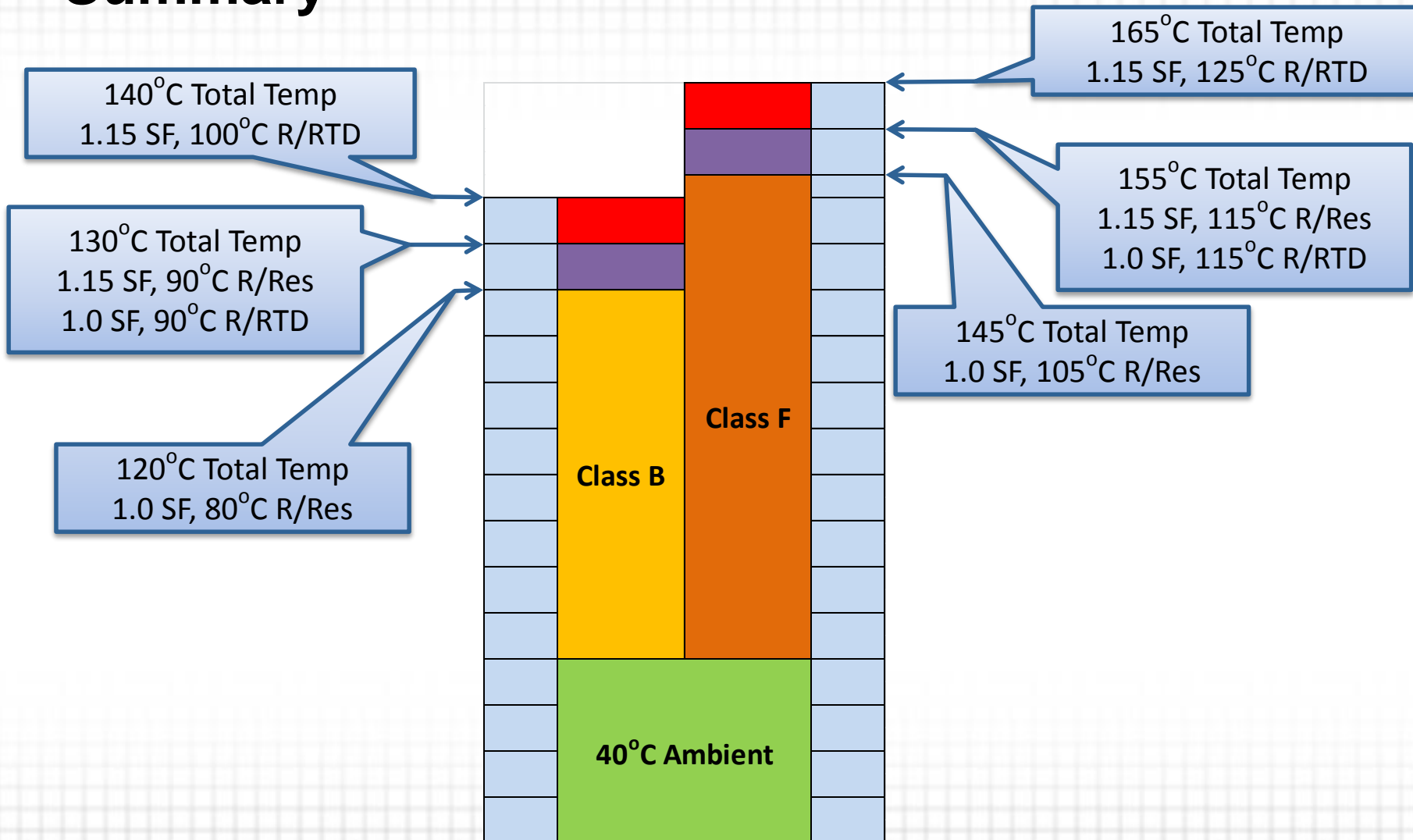

# Temperature Rise & Increased Ambient

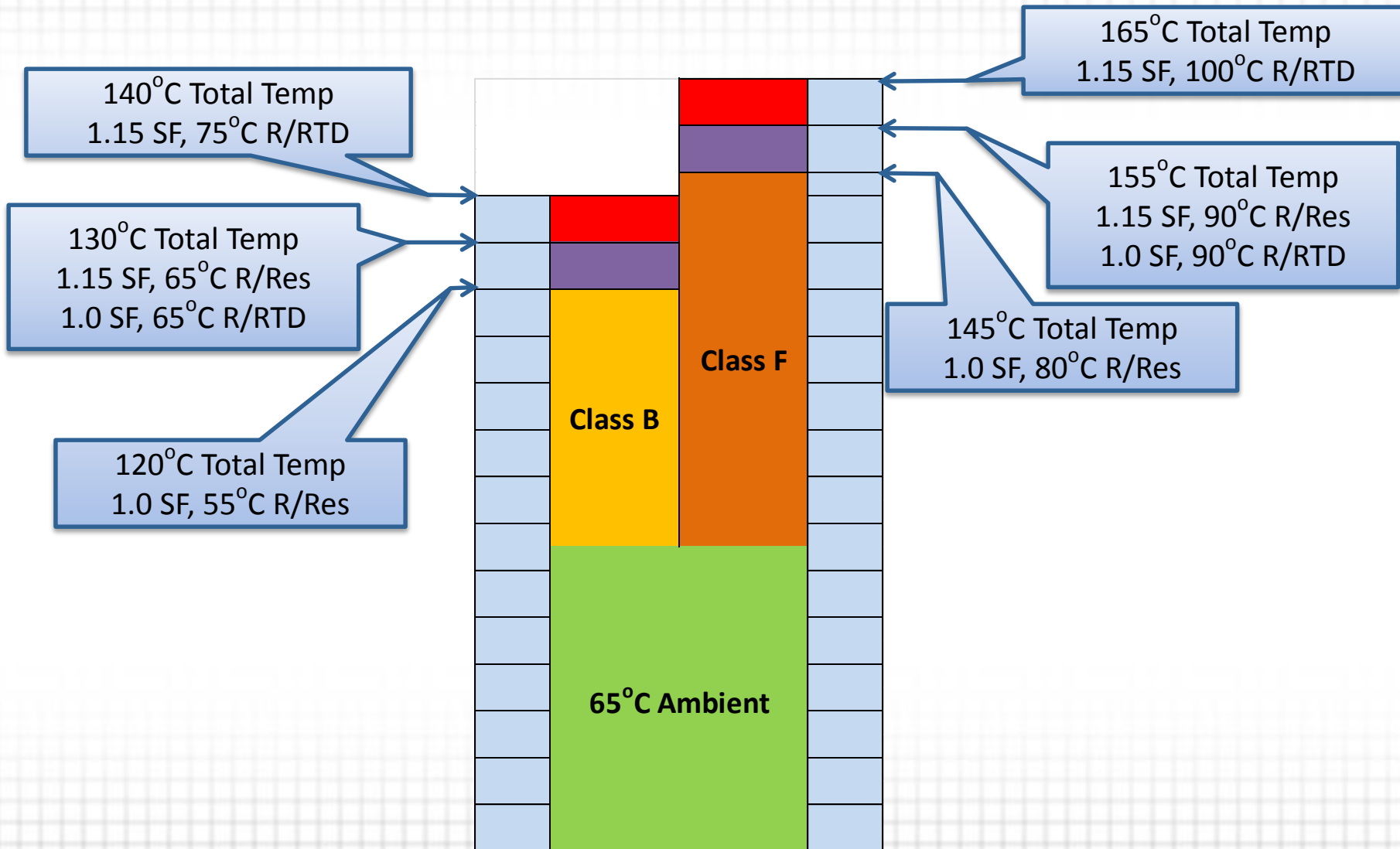

# Effect of Altitude on Temperature Rise

## NEMA MG 1 - 2011

### 20.8.4 Temperature Rise for Altitudes Greater than 3300 Feet (1000 Meters)

For machines which operate under prevailing barometric pressure and which are designed not to exceed the specified temperature rise at altitudes from 3300 feet (1000 meters) to 13200 feet (4000 meters), the temperature rises, as checked by tests at low altitudes, shall be less than those listed in 20.8.1 and 20.8.2 by 1 percent of the specified temperature rise for each 330 feet (100 meters) of altitude in excess of 3300 feet (1000 meters).

Example: 6600 ft altitude

$$1 - \frac{6,600 - 3,300}{33,000} = 0.9$$

$$80 \times 0.9 = 72$$

**Therefore, motor must be sized for 72°C Rise by Res  
at full load for B Rise**

# Motor Standards

# Motor Standards

- NEMA MG-1
- IEEE-841

# NEMA Standards

- National Electrical Manufacturers Association (NEMA)
  - › ANSI/NEMA MG-1, 2011
    - The standard for electric motors and generators in North America.
    - “Bible” for Manufacturers selling motors in North America.
    - Establishes standards for motor dimensions, construction, testing and performance.
    - Establishes standard frame sizes.

# NEMA Frame Sizes

- ANSI/NEMA MG-1, Section 1, Part 4: Dimensions, Tolerances and Mounting – Frame Sizes
  - › For two digit frames, the frame size is the D-dimension in inches x 16
  - › For Three and Four digit frame, the first two digits of the frame size is the D-dimension in inches x 4
  - › The third and fourth digit is the value of 2F in inches from table 4-2

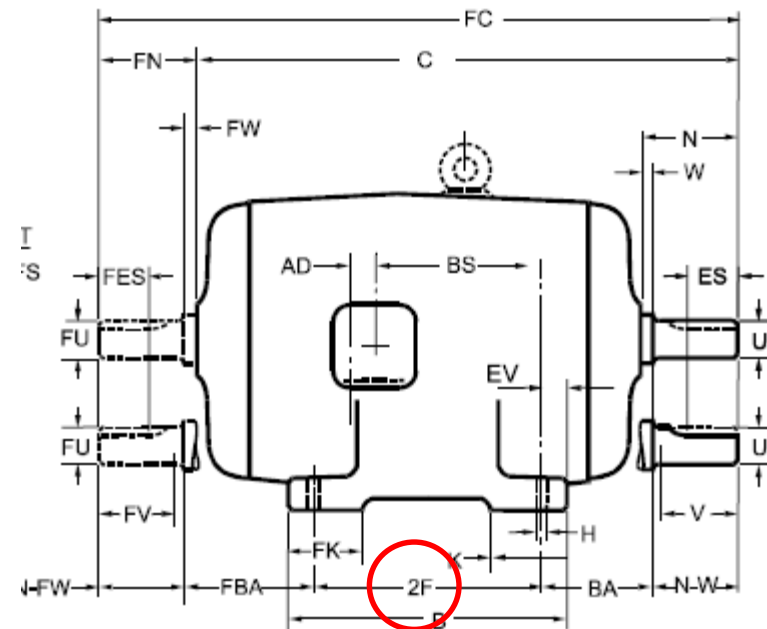
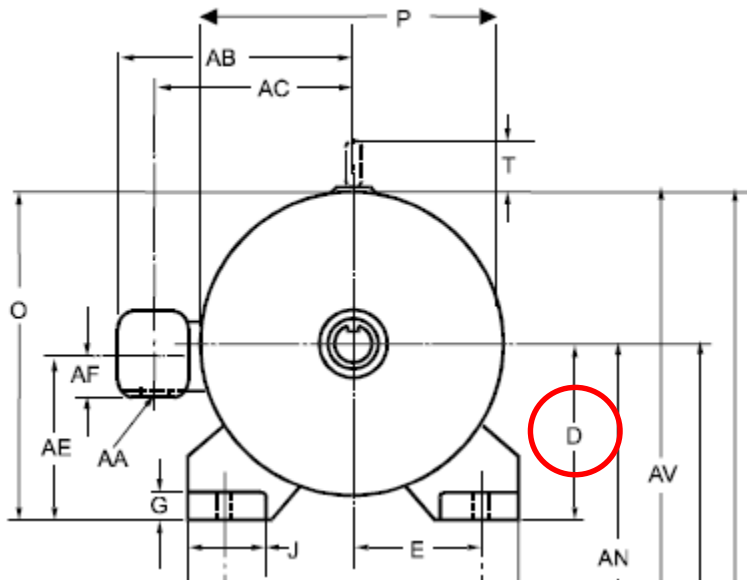

# NEMA Frame Sizes

What is shaft height of a NEMA 286T Frame?

$D = 7.00''$

What is the distance between bolt holes in feet?

$2F = 11''$

Table 4-2  
MACHINE FRAME NUMBERING

Frame Number Series	D	Third/Fourth Digit in Frame Number						
		1	2	3	4	5	6	7
2 F Dimensions								
140	3.50	3.00	3.50	4.00	4.50	5.00	5.50	6.25
160	4.00	3.50	4.00	4.50	5.00	5.50	6.25	7.00
180	4.50	4.00	4.50	5.00	5.50	6.25	7.00	8.00
200	5.00	4.50	5.00	5.50	6.50	7.00	8.00	9.00
210	5.25	4.50	5.00	5.50	6.25	7.00	8.00	9.00
220	5.50	5.00	5.50	6.25	6.75	7.50	9.00	10.00
250	6.25	5.50	6.25	7.00	8.25	9.00	10.00	11.00
280	7.00	6.25	7.00	8.00	9.50	10.00	11.00	12.50
320	8.00	7.00	8.00	9.00	10.50	11.00	12.00	14.00
360	9.00	8.00	9.00	10.00	11.25	12.25	14.00	16.00
400	10.00	9.00	10.00	11.00	12.25	13.75	16.00	18.00
440	11.00	10.00	11.00	12.50	14.50	16.50	18.00	20.00
500	12.50	11.00	12.50	14.00	16.00	18.00	20.00	22.00
580	14.50	12.50	14.00	16.00	18.00	20.00	22.00	25.00
680	17.00	16.00	18.00	20.00	22.00	25.00	28.00	32.00

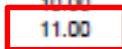
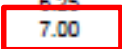



# Speed vs Torque

## NEMA MG 1- 20.10

### 20.10.1 Standard Torque

The torques, with rated voltage and frequency applied, shall be not less than the following:

Torques	Percent of Rated Full-Load Torque
Locked-rotor*	60
Pull-up*	60
Breakdown*	175

### 20.10.2 High Torque

When specified, the torques with rated voltage and frequency applied, shall not be less than the following:

Torques	Percent of Rated Full-load Torque
Locked-rotor	200
Pull-up	150
Breakdown	190

### 20.10.3 Motor Torques When Customer Specifies A Custom Load Curve

When the customer specifies a load curve, the torques may be lower than those specified in 20.10.1 provided the motor developed torque exceeds the load torque by a minimum of 10% of the rated full-load torque at any speed up to that at which breakdown occurs, with starting conditions as specified by the customer ( refer to 20.14.2.3 ).

# IEEE Standard 841-2009

*Severe Duty, TEFC, Squirrel Cage Motors  
Up to and Including 370 KW (500 HP)*

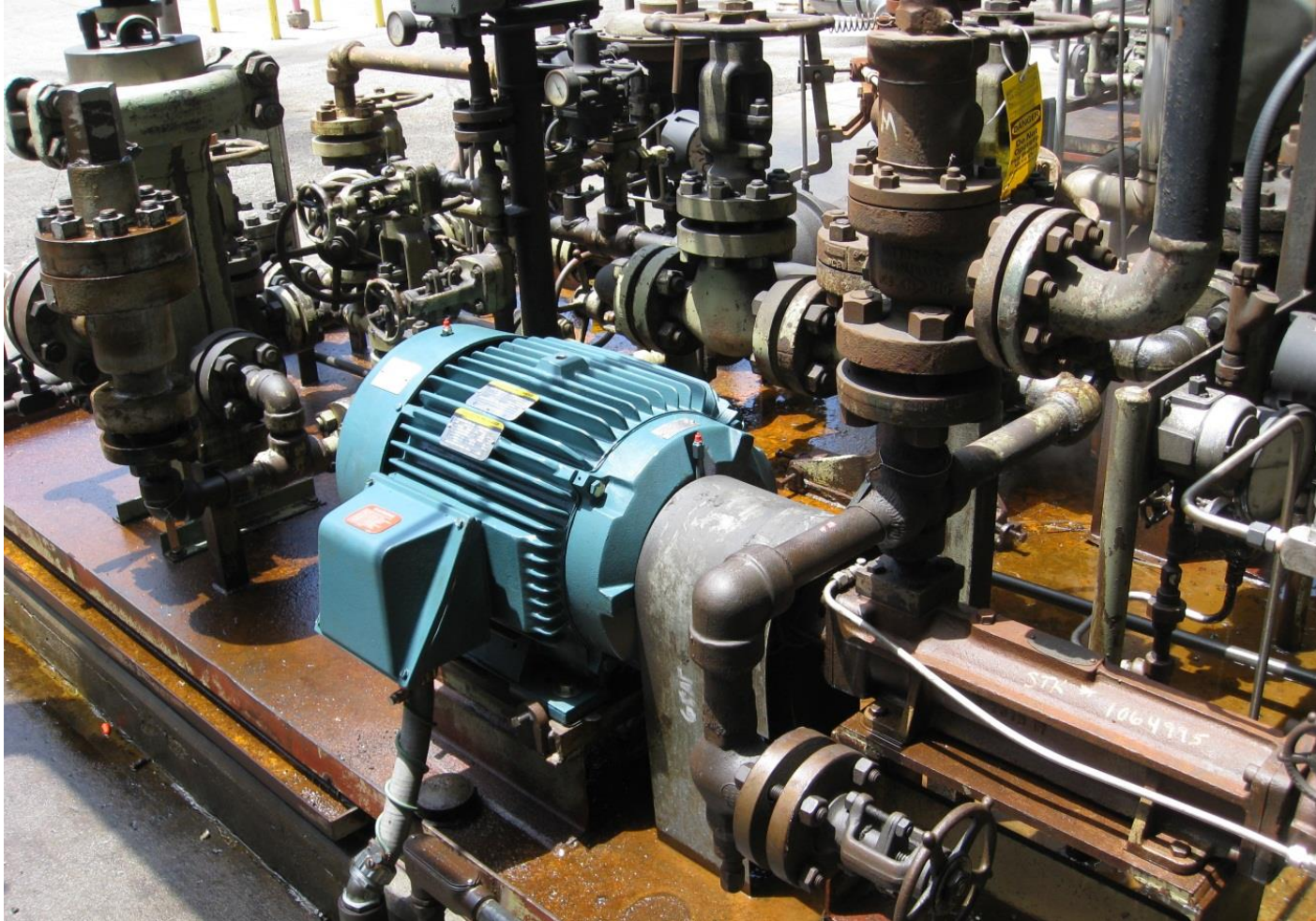

# Purpose of IEEE 841

- Define an Industry Acceptable Severe Duty Motor
- Eliminate Individual User Specs
- Readily Available Feature Rich Motors
- Reliability Focus by Defining:
  - › Mechanical and electrical performance
  - › Insulation systems
  - › Corrosion protection
  - › Testing



# History of IEEE 841

- 1986 – IEEE RP 841 – IAS Petro-Chemical Committee
  - › 250HP and Below
  - › 600V and below
  - › Severe duty
  - › High efficiency
- 1994 - IEEE 841
  - › Increased ratings to 500 HP or less
  - › Increased voltage up to 4000V
  - › Added TEFC in the title
- 2001 – IEEE 841
  - › Included the IAS Pulp and Paper Committee in the working group
  - › Added Metric Units
  - › Data Exchange – Added PIP data sheet
- IEEE 841-2009
  - › Premium Efficient
  - › Added Class 1, Division 2 as a “Usual service condition”
  - › Increased use of metric equivalents
  - › IP 55 for all ratings

# IEEE 841 Key Requirements

- Premium Efficient
- TEFC (TENV)
- 500 HP and Below
- 4000V and Below
- NEMA Frames 143T and Larger
- Severe Duty

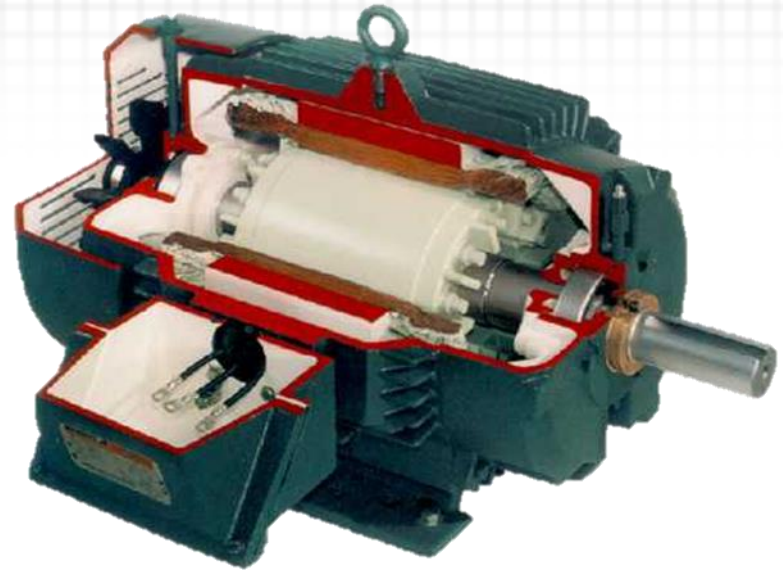

# IEEE 841 Key Requirements

- Usual Service Conditions
  - › -25°C to +40°C ambient
  - › Maximum altitude = 1000M
  - › Humid, chemical (corrosive), or salty atmospheres
  - › Full voltage starting
  - › Class I, Division 2 atmosphere



# IEEE 841 Key Requirements

- NEMA Frame assignments
- 2, 4, 6, and 8 pole only
- IP55
- NEMA Design B
- If on ASD, consult manufacturer
- Class F Insulation
- Form Wound, Sealed Insulation for 2300V and above.

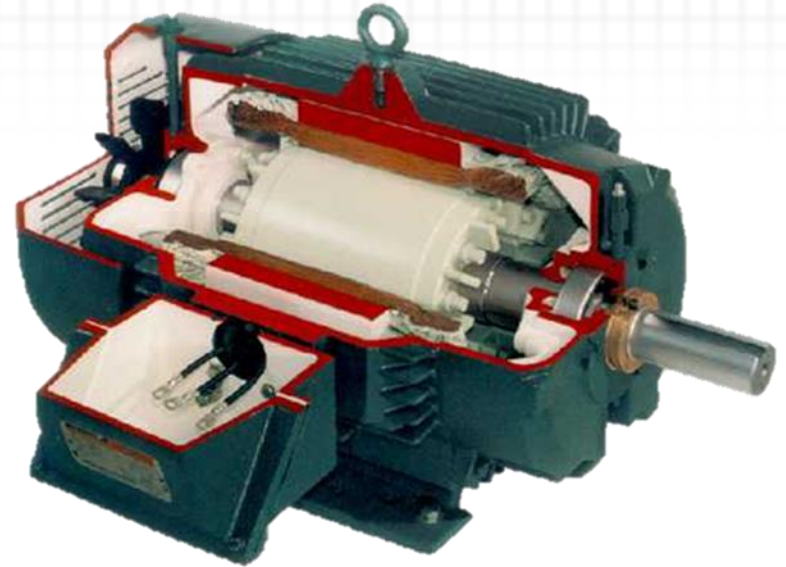

# IEEE 841 Key Requirements

- B Rise by Resistance at FL
- Max 200°C Surface Temps
- Anti-friction Bearings
  - › 45°C rise (50°C on 2P)
- Copper or Aluminum Rotor Cage
- “T” or “TS” Shaft Extensions
- Cast Iron Construction
- Coplanar feet within 0.005 in
- Maximum 1.5 draft angle at feet
- Non-sparking fan (Bronze alloy or conductive plastic)

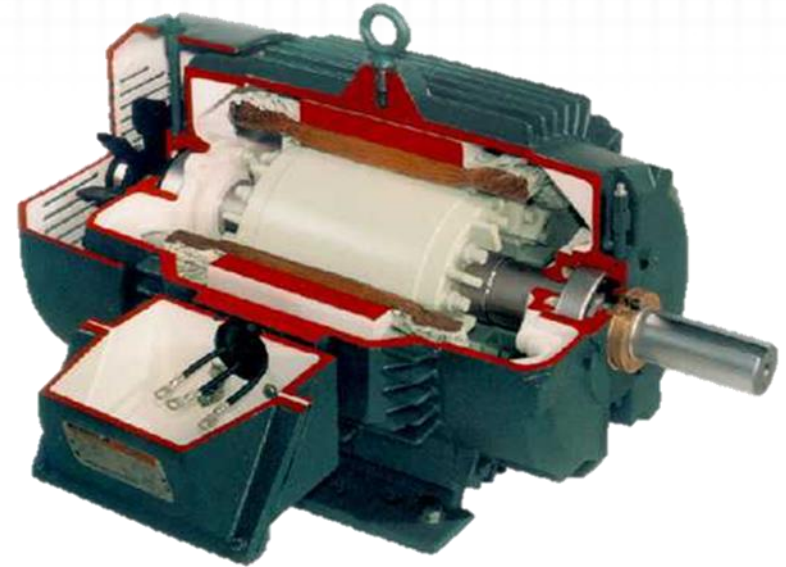



# IEEE 841 Key Requirements

- Main Terminal Box
  - › Cast Iron
    - Max 600V
    - Max 445T
    - Defined Volume
  - › NEMA Type II
    - Above 600V or
    - Above 445T

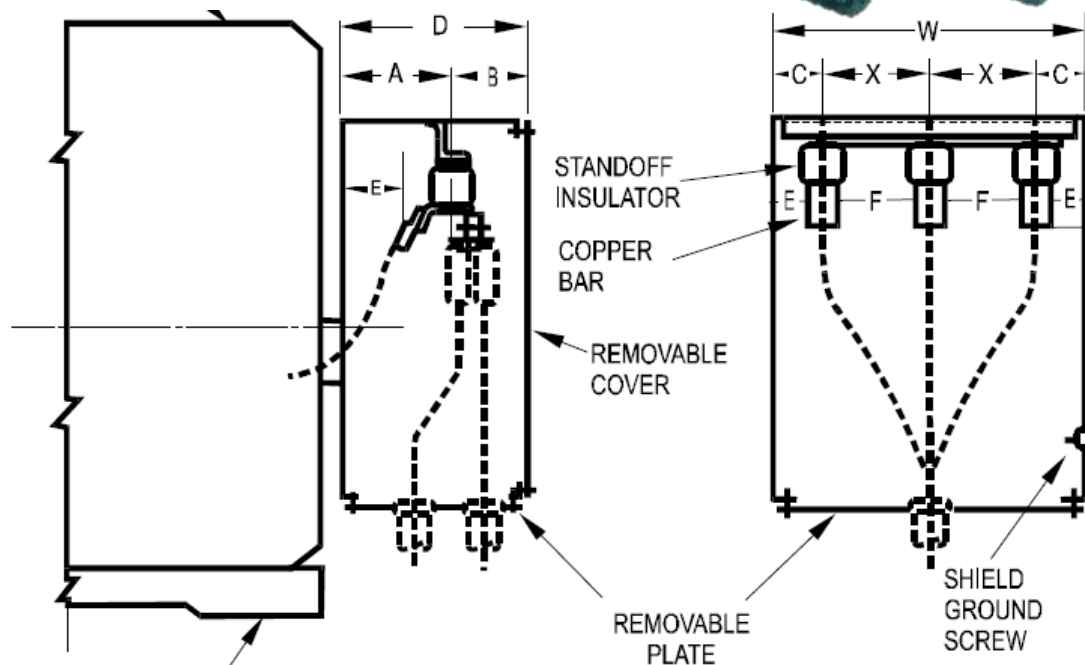

# IEEE 841 Key Requirements

- Main Terminal Box
  - › Barrier at Frame
  - › Ground Lug
  - › 3 Leads
    - Some allowance for 2/phase
  - › Copper Alloy, Seamless Compression Type Lugs

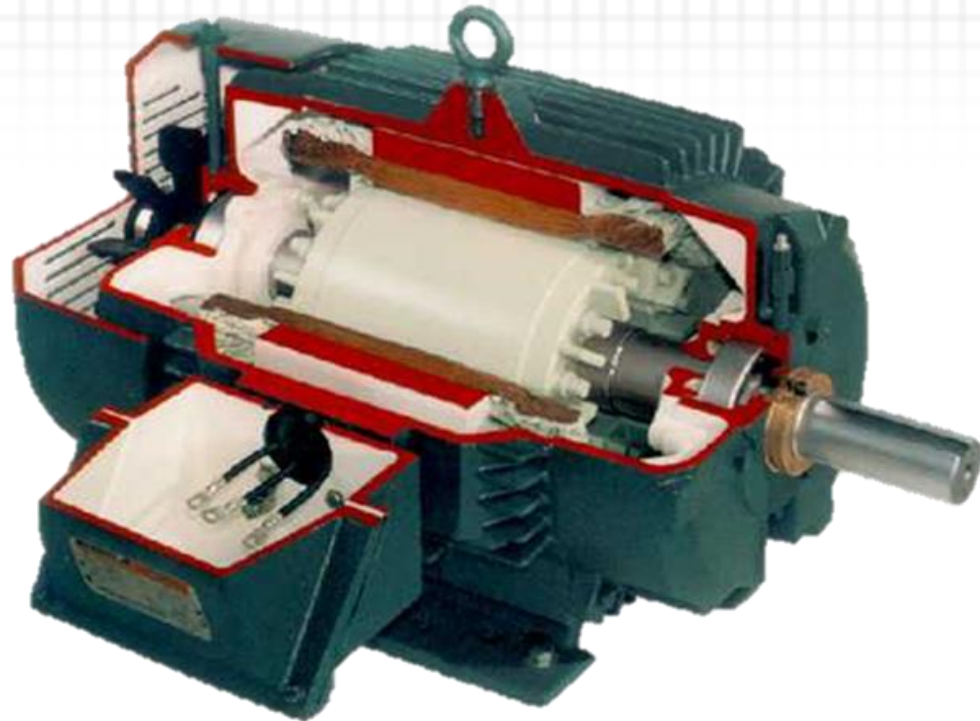

# IEEE 841 Key Requirements

- Automatic Drains
  - › All Frames
  - › Terminal Boxes Above 600V and Above 445T Frames
- Blind Hole for Eyebolt
- 90 dBA Sound Power
- Vibration - Unfiltered
  - › 0.08 in/s – 2P, 4P, and 6P
  - › 0.06 in/s – 8P
  - › 0.06 in/s - Axial
- Vibration – 2n & 2f
  - › 0.05 in/s

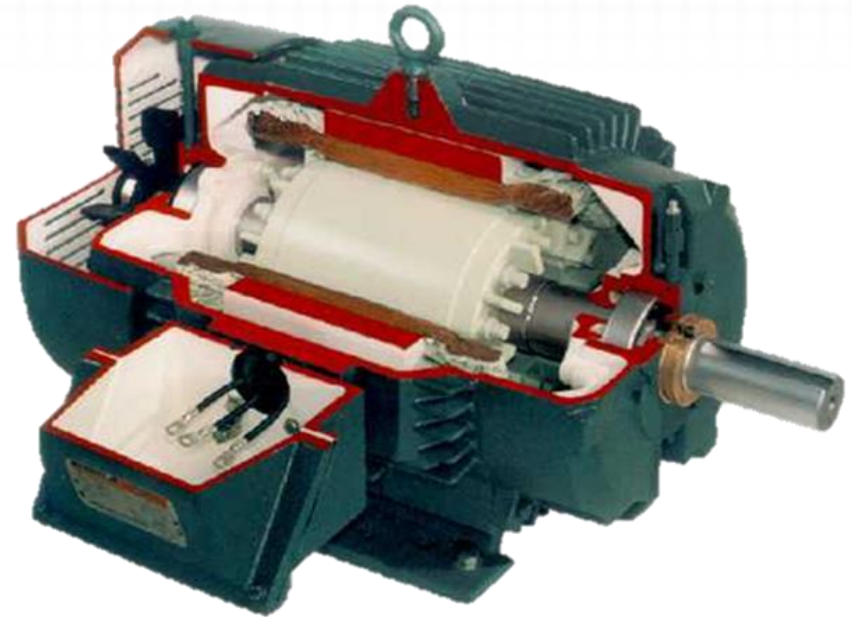

# IEEE 841 Key Requirements

- Corrosion Resistance
  - › 96 Hr. Salt Spray Type Test
    - Frame
    - Endshields
    - Fan Covers
    - Terminal Housings
  - › 720 Hr. Salt Spray Type Test
    - Nameplate
  - › Internal Corrosion Resistance
    - Stator, Rotor, and Shaft
  - › Assembly
    - Corrosion Preventative to Frame to Endshield Fits
    - Lubricant Added to Threaded Surfaces

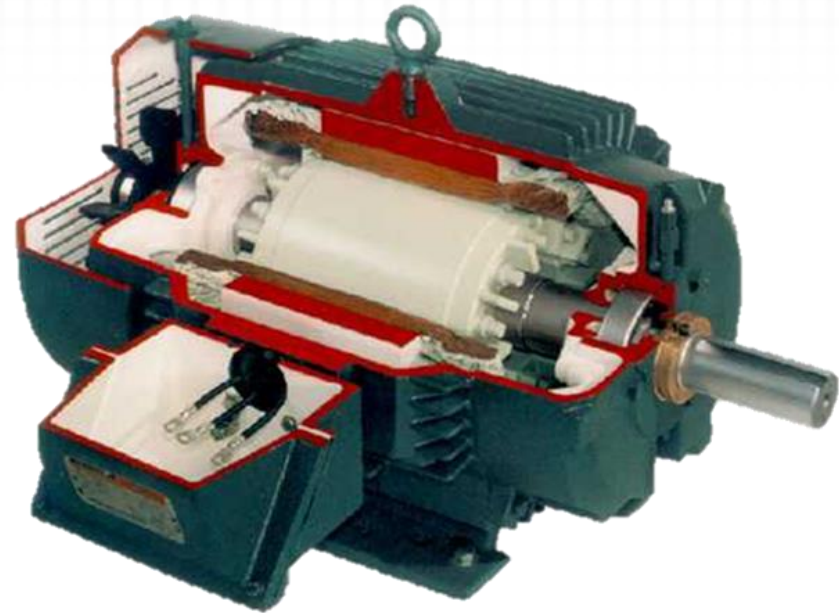

# IEEE 841 Testing

## 9.4 Test information supplied with motor

Winding resistance; no load current, voltage, and speed; and **five unfiltered vibration readings (velocity)** shall be supplied with the motor at the time of shipment. Vibration measurements shall include two readings, perpendicular to each other, in the radial plane on both ends of the motor (near each bearing) plus one axial reading.

**Typical report of test form for routine tests**

Name of Manufacturer \_\_\_\_\_  
 Address of Manufacturer \_\_\_\_\_ Date of Test \_\_\_\_\_  
 \_\_\_\_\_ Manufacturer's Order No. \_\_\_\_\_  
 Purchaser \_\_\_\_\_ Purchaser's Order No. \_\_\_\_\_

**Nameplate Data**

Rated hp/kW	Service Factor	Rated Speed r/min	Phase	Frequency Hz	Volts	Amperes

Type	Frame	(Temp Rise by method Indicated)	(Ambient temp and Insulation Class)	Time Rating	Design Letter	Code Letter for Locked kVA/hp

**Test Characteristics**

Serial No.	No Load					Locked Rotor				Wound Rotor Open-Circuit Voltage	High Potential Test Voltage	Stator Winding Resistance Between Terminals	
	Volts	Frequency Hz	Speed r/min	A m-peres	Kilo-watts*	Volts	Fre-quency Hz	Am-peres	Kilo-watts*			Ohms	Temp in °C

\*If measured, optional.

# APPLICATION CONSIDERATIONS: HAZARDOUS LOCATIONS

# Hazardous Locations:

- Areas where concentrations of combustible gasses, vapors, dusts, fibers and flyings can be present



# The basics- Hazardous Areas

- Hazardous Locations are areas where concentrations of combustible gasses, vapors, dusts, fibers can be present some of the time.
  - › Class 1: Explosive Gas/Vapor
  - › Class 2: Explosive Dust
  - › Class 3: Fibers
- Areas with these hazards present are classified as to the risk, based on how close you are to the source of release, and what that substance being released is.
  - › Division 1: Hazard is present during normal operation
  - › Division 2: Hazard is present during abnormal operation



# Hazardous Area Classification

<b>Division 1</b> Where ignitable concentrations of flammable gasses or liquids can exist all or the time or some of the time under normal operating conditions	<b>Zone 0</b> Where ignitable concentrations of flammable gasses, vapors or liquids are present continuously or for long periods of time under normal operating conditions.
	<b>Zone 1</b> Where ignitable concentrations of flammable gasses, vapors or liquids are likely to exist under normal operating conditions.
<b>Division 2</b> Where ignitable concentrations of flammable gasses or liquids are not likely to exist under normal operating conditions	<b>Zone 2</b> Where ignitable concentrations of flammable gasses, vapors or liquids are not likely to exist under normal operating conditions.

# Hazardous Area Classification

<b>Standard</b>	<b>Flammable Material Present Continuously</b>	<b>Flammable Material Present Intermittently</b>	<b>Flammable Material Present Abnormally</b>
<b>US NEC 500 CA CEC Annex J</b>	<b>Division 1</b>		<b>Division 2</b>
<b>US Classes</b>	<b>Further classified as Class I for GAS, Class II for DUST and Class III for FIBRES and FLYINGS</b>		

# Explosive Gas Equipment Grouping

Hazardous materials from an explosive standpoint typically have a temperature associated with their ignition.

<b>Typical Gas</b>	<b>US (NEC 505) CA (CEC Section 18) EU IEC</b>	<b>US (NEC 500) CA (CEC Annex J)</b>
<b>Acetylene</b>	<b>Group IIC</b>	<b>Class I / Group A</b>
<b>Hydrogen</b>	<b>Group (IIB + H<sub>2</sub>)</b>	<b>Class I / Group B</b>
<b>Ethylene</b>	<b>Group IIB</b>	<b>Class I / Group C</b>
<b>Propane</b>	<b>Group IIA</b>	<b>Class I / Group D</b>
<b>Methane</b>	<b>Group I *</b>	<b>Mining *</b>

\* Not within the scope of NEC. Under the jurisdiction of MSHA. Not within the scope of CEC.

# Temperature Class Markings

Temperature	US (NEC 505) CA (CEC Section 18) EU IEC	US (NEC 500) CA (CEC Annex J)
450° C	T1	T1
300° C	T2	T2
280° C	-	T2A
260° C	-	T2B
230° C	-	T2C
215° C	-	T2D
200° C	T3	T3

Temperature	US (NEC 505) CA (CEC Section 18) EU IEC	US (NEC 500) CA (CEC Annex J)
180° C	-	T3A
165° C	-	T3B
160° C	-	T3C
135° C	T4	T4
120° C	-	T4A
100° C	T5	T5
85° C	T6	T6

Temperature Classes are not used for Dust per US NEC 506 , EU and IEC. Actual temperature is shown in degrees Celsius as “ T \_ \_ \_ ° C” (i.e. T120° C)

# Customer Responsibilities

- It is the responsibility of the Customer identify and select the proper Hazardous Area classification (i.e. Division, Class, Group and Temp Code) for equipment to meet the requirements of each installation.
- Baldor & ABB can advise what listing and approvals our motors carry, but cannot evaluate nor recommend what motors may be suitable for use in hazardous environments.

# Protection Concepts

For hazardous areas there are several protection concepts offered:

- Division 1 and Zone 1 : If the risk of exposure is likely the motor construction is based on a special motor enclosure that will contain the explosion
- Division 2 and Zone 2: When the risk of exposure is not likely, the motor construction is close to an ordinary location motor that minimizes the risk of sparking.

# Motors Operating in Potentially Explosive Atmospheres

- Hazardous duty motors are certified for specific applications in specific environments.
- They are not as interchangeable as ordinary locations motors.
- Because of their certification they may have limitations on their design flexibility.

# Explosion Proof (DIV 1)



Similar design considerations for Division 1 and Ex d :

- Special motor design
  - › Frame
  - › End Plates
  - › Conduit Box
- Used within the electrical design rating specified
- External surface temperatures are kept below specified ignition temperatures





# Non Sparking (DIV 2)



## Design considerations for Division 2

- Open or Enclosed Motor construction is close to that of an ordinary location motor
- No sparks can occur that would ignite the flammable material.
- Used within the electrical design rating specified
- Internal and external surface temperatures are kept below specified ignition temperatures

# Hazardous Location Nameplates

 <b>LISTED</b> CLASS I GROUP D CLASS I ZONE I GROUP - IIA ELECTRIC MOTOR FOR HAZARDOUS LOCATIONS			
NO.		CC	XX
SER #	F1205250002		
SPEC	200-230		
CAT. NO.	9.6-9		
H.P.	1725	T. CODE	56YZ
VOLTS	60		
AMPS	3		
R.P.M.	1.15		
HZ	K	PH	F CLASS X
SER. F.	80	DES	X CODE X
RATING	6205		
FRAME	6203	NEMA NOM EFF	XX %
USABLE @ 208V	OPSB	A PF	B %
SAMPLE ONLY			
BALDOR ELECTRIC CO. FORT SMITH, AR. U.S.A.		NP0015XPSL	

- Hazardous location motors require a nameplate showing the Hazardous Location Classification and Certification.
- Motor nameplates that carry the hazardous certifications may only be changed/modified at the manufacturer's plant.

# Application Considerations: Using VFD's on Induction Motors

# Adjustable Speed Applications

- Centrifugal Pumps
- Centrifugal Fans/Blowers
- Centrifugal Compressors
- Conveyors
- Agitators
- Screw pumps

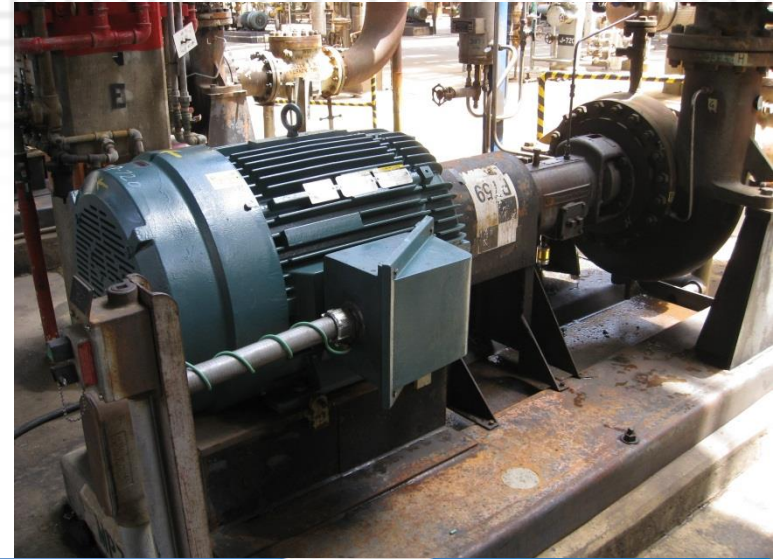

# Why use VFD's?

- Affinity Pump/Fan Laws apply
  - › Flow is Directly Proportional to Speed
  - › Pressure varies as Square of Speed
  - › HP varies as Cube of Speed

Speed	100%	90%	80%	70%	60%	50%	40%	30%
Volume	100%	90%	80%	70%	60%	50%	40%	30%
Pressure	100%	81%	64%	49%	36%	25%	16%	9%
HP Req'd	100%	73%	51%	34%	22%	13%	6%	3%

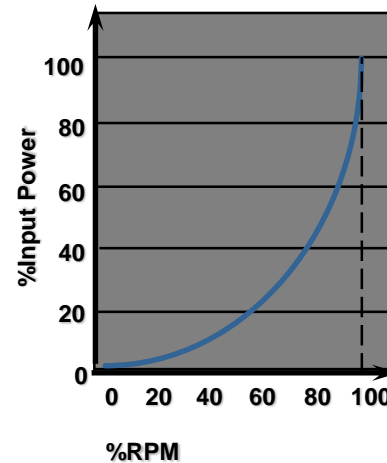
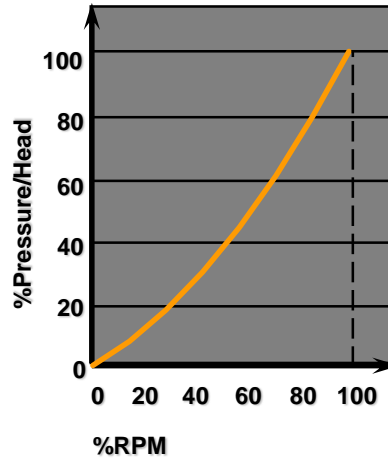
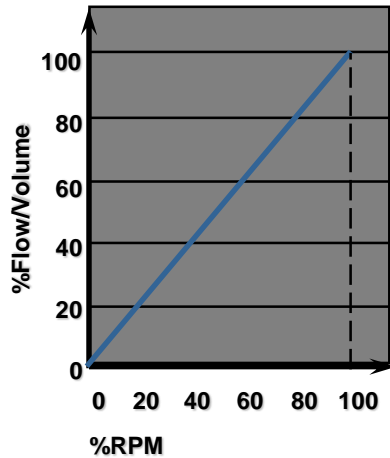

# Considerations for Motors Used on VFD's

- Modern Variable Frequency Drives (VFD) are common throughout industry
- Industrial motor manufacturers use different terms to signify the applicability of their motors for use on VFD's:
  - › “Inverter Ready”
  - › “Inverter Duty”
  - › “Inverter Capable”
- These terms are common applied to “General Purpose” motors that may run on sine wave or Inverter waveforms
- Does not really reference a standard
- Most motors will run on VFD's....Some longer than others

# Considerations for Motors Used on VFD's

- Three aspects of motor and application that typically are concern when operating on VFD
  - › Load Characteristics: Constant Torque/Variable Torque
  - › Minimum Speed/Turn Down Ratio
  - › Stator Insulation
  - › Bearing Fluting

# Considerations for Motors Used on VFD's

- Load Characteristics:
  - › Constant Torque/Variable Torque
  - › Speed Range
    - Less cooling as motor slows
    - CT load at FL AMPS
    - Motor Temp concern
    - At 50% speed the motor current (temp) of CT load much higher than VT load
  - › Typical Constant torque loads:
    - Conveyors
    - PD pumps
    - Screw conveyors
  - › Typical Variable torque loads:
    - Fans
    - Centrifugal pumps
    - Agitators

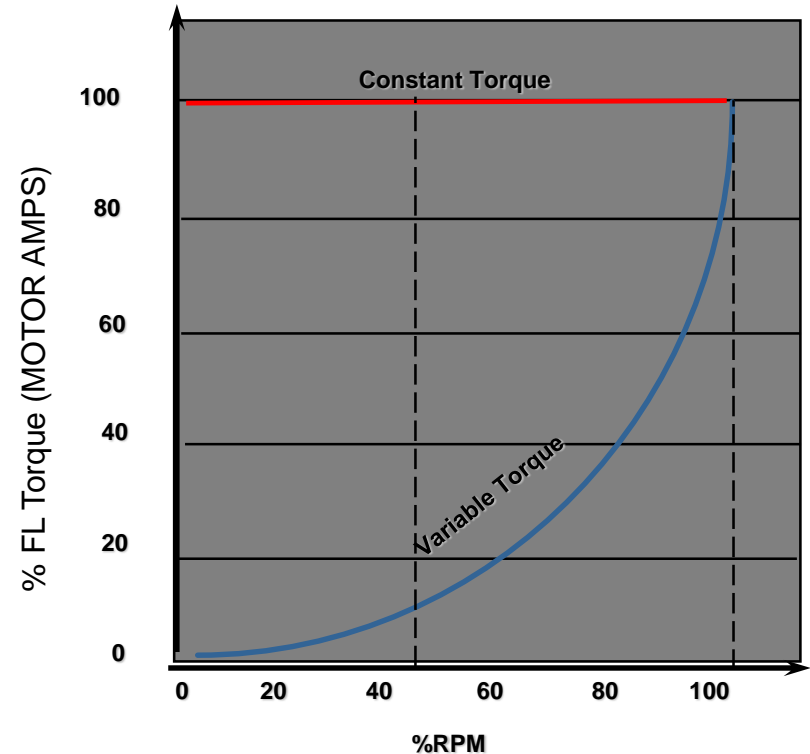



# Considerations for Motors Used on VFD's

- Stator Issues –
  - › Impedance mismatch between drive and motor
  - › Carrier frequency / switching frequency
  - › **Reflected waveform** can cause voltage doubling at the motor
  - › **dV/dT** – Rise time of IGBT's
  - › Voltage spikes
- Insulation Failure
  - › Highest voltage stress occurs between the turns in the first one or two coils in a phase group
- Insure motor meets requirements of NEMA MG-1, Part 31.4.4.2
  - › Voltage Stress, Suitable for:
    - 3.1 PU @ 0.1  $\mu$ S – Max 600V
    - 2.04 PU @ 1  $\mu$ S – Above 600V
- Load reactor
- Output filters



# Considerations for Motors Used on VFD's

- Special considerations: Shaft voltage build-up/Common mode
  - › Voltage build-up of 5-30VDC on the shaft is possible
  - › This will either bleed away or flash to ground
  - › Typical flash point is bearings
  - › This will pit the bearing and the race

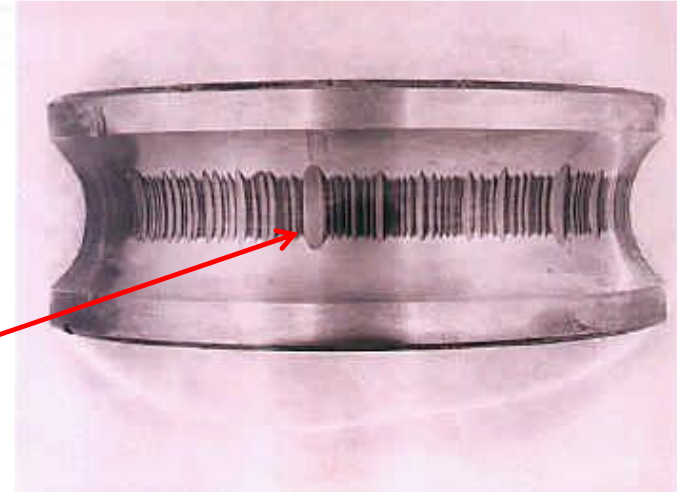

- Common solutions include
  - › Utilize proper grounding and cabling techniques
  - › Decrease carrier frequency from drive
  - › Insulate bearings
  - › Utilize shaft grounding brush

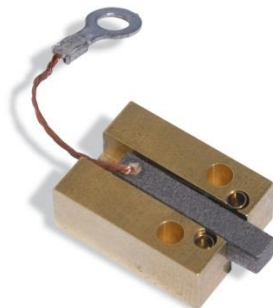

# Proper Cable Selection

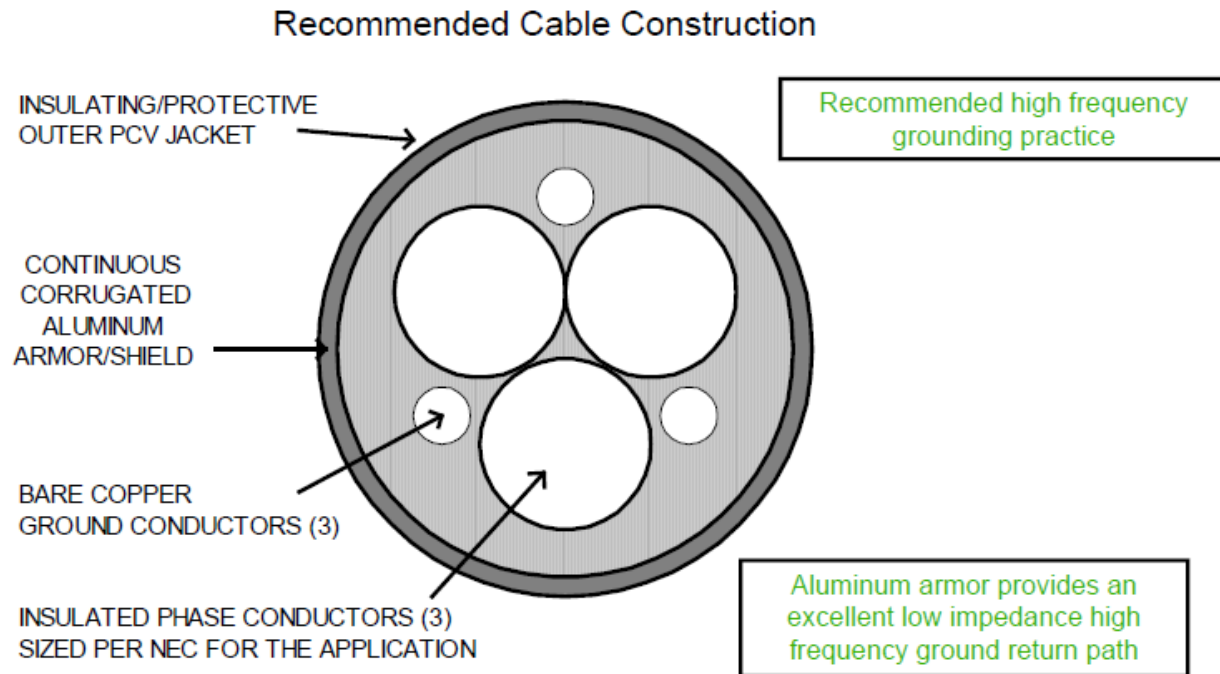

# Proper Grounding

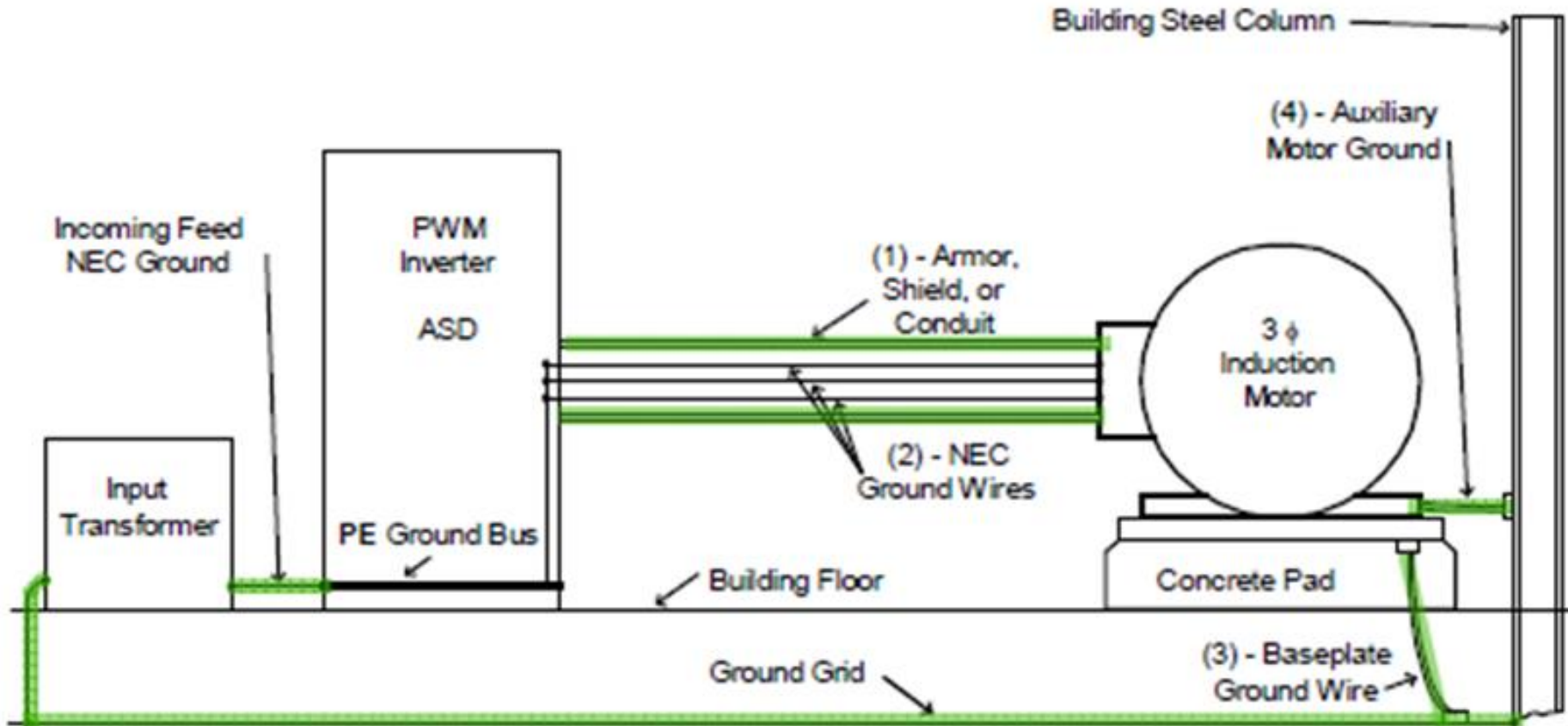

# Considerations for Motors Used on VFD's

- VFD's can be a significant non-linear load on a power system which can result in:
- Harmonic Current Distortion —
  - › Added heating in transformers and cables, reduces available capacity
  - › May stimulate a PF correction resonance condition
    - Excessive voltage
    - Overheating of capacitors
    - Tripping of protection equipment
    - Shutdown / damage to electronic equipment
  - › May cause telephone or electronic interference
- Best solution for harmonics is often use of an Ultra-Low Harmonics drive with LCL Filter and active front end.

# Common Failure Mode of Motors

# Common Bearing Failure Modes

- Electrical erosion (shaft currents)
- Inadequate lubrication / contamination
- Damage from vibration
- Damage caused by improper installation and set-up (mounting)
- Misalignment

# Effects of Electrical Erosion

- Effects on the raceway
  - › Local melting of the metal surfaces
  - › Small craters of re-hardened material are formed
  - › Small particles of melted material break loose
  - › Softer material below yields risk for spalling

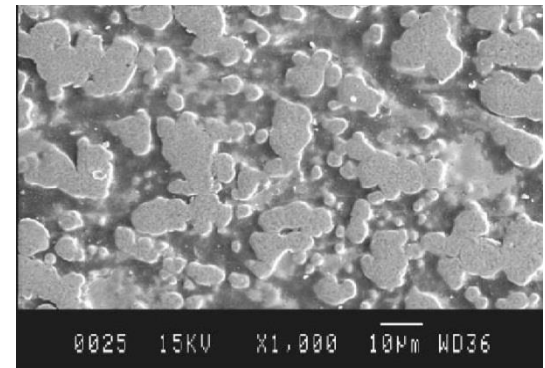
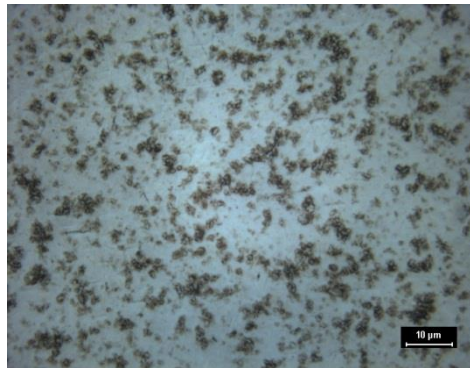



# Effects of Electrical Erosion

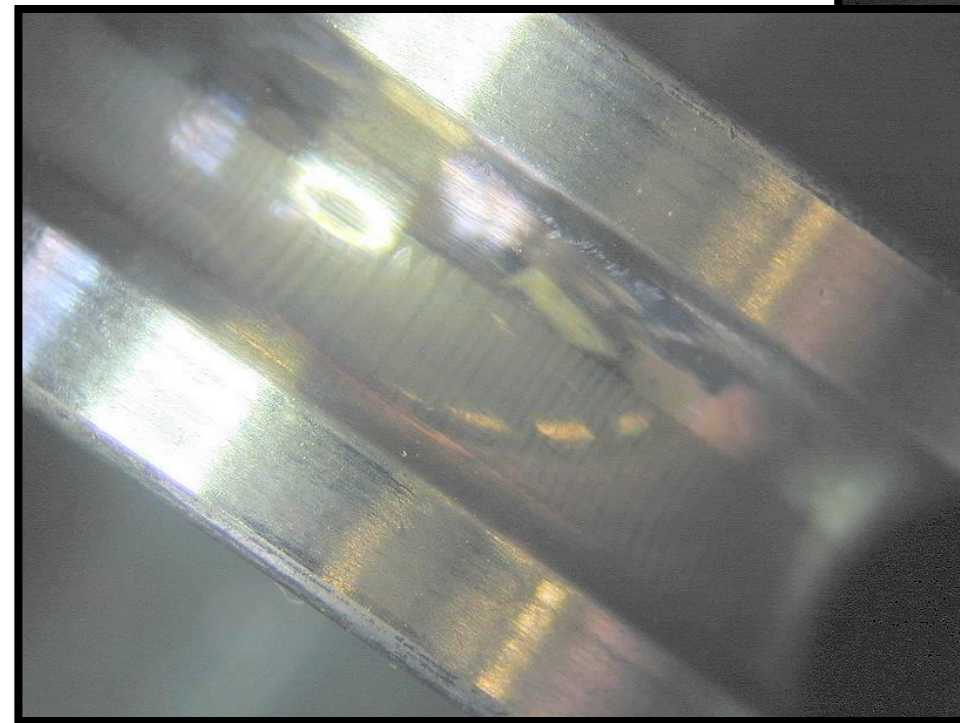
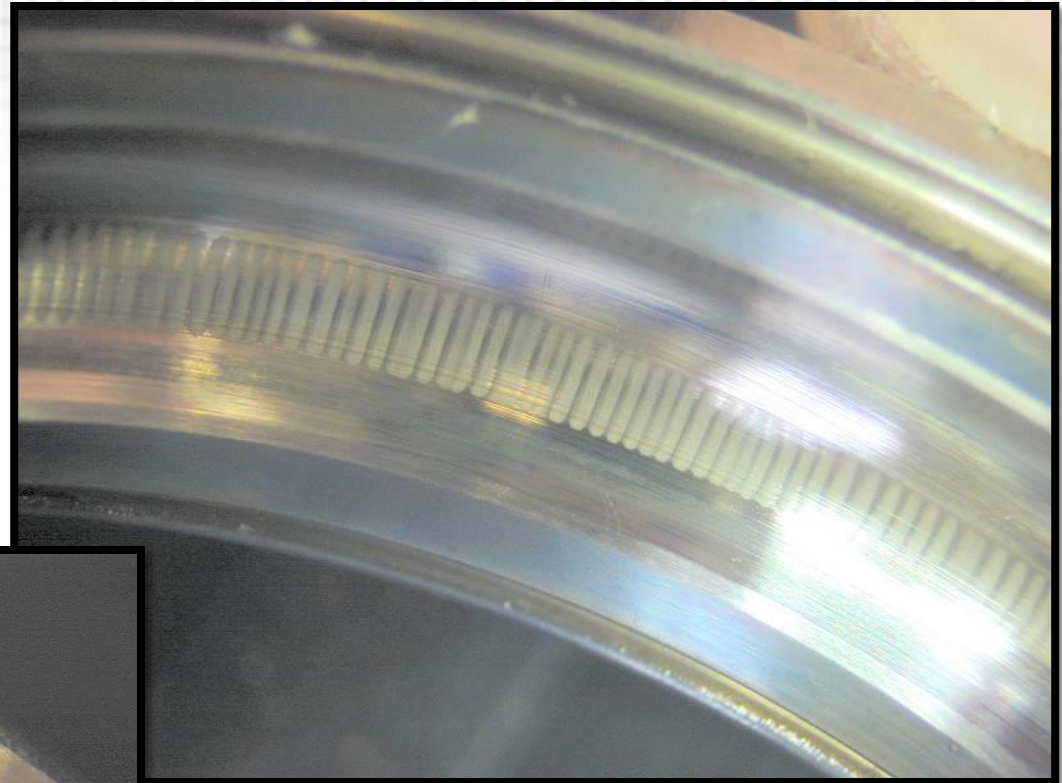
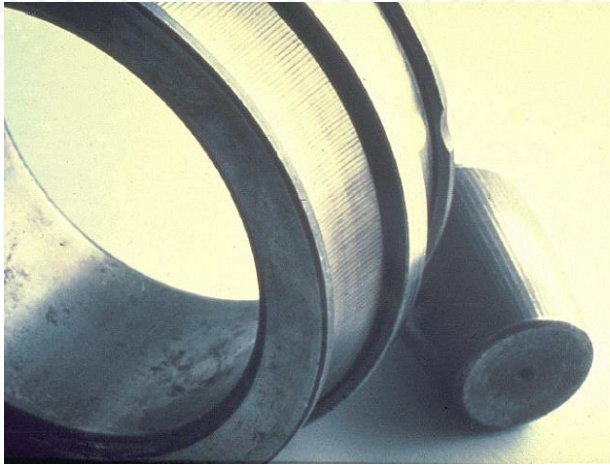

- Effects on the raceway
  - › Fluting

# Inadequate Lubrication & Contamination

## Abrasive wear

- Metal to metal contact due to inadequate lubrication.
- Surface wear, glazing, frosting.
- Leads to cracks and eventually spalling.



# Inadequate Lubrication & Contamination

## ■ Corrective action

- Check motor manual
- Check re-greasing interval
- If contaminated: check sealing
- A lubricant with a higher viscosity may be required
- A grease with different additives or temperature range may be required



# Grease Compatibility

	Aluminum Complex	Barium	Bentonite Clay	Calcium	Calcium 12-hydroxy	Calcium Complex	Calcium Sulfonate	Lithium	Lithium 12-Hydroxy	Lithium Complex	Polyurea	Sodium
Aluminum Complex	C	I	I	I	C	I	B	I	I	C	I	I
Barium	I	C	I	I	C	I	B	I	I	I	I	I
Bentonite Clay	I	I	C	C	C	I	B	I	I	I	I	I
Calcium	I	I	C	C	C	B	I	C	B	B	I	I
Calcium 12-hydroxy	C	C	C	C	C	B	NA	C	C	C	I	I
Calcium Complex	I	I	I	B	B	C	C	I	I	C	B	I
Calcium Sulfonate	B	B	B	I	NA	C	C	C	C	C	B	I
Lithium	I	I	I	C	C	I	C	C	C	C	I	B
Lithium 12-Hydroxy	I	I	I	B	C	I	C	C	C	C	I	I
Lithium Complex	C	I	I	B	C	C	C	C	C	C	I	B
Polyurea	I	I	I	I	I	B	B	I	I	I	C	I
Sodium	I	I	I	I	I	I	I	B	I	B	I	C

**C = Usually Compatible**

**B = Borderline**

**I = Incompatible**

# Failure Causes of Electric Motors

Motors fail for a variety of reasons

Rotor  
Porosity  
End Ring Separation  
Delamination

Stator  
Turn to turn short  
Coil head punch through  
Rotor drops into stator  
(bearing failure)\*

Bearings  
Contamination Ingress  
Lack of lube/ mixing lube  
Vibration

EPRI study of 6000 utility motors

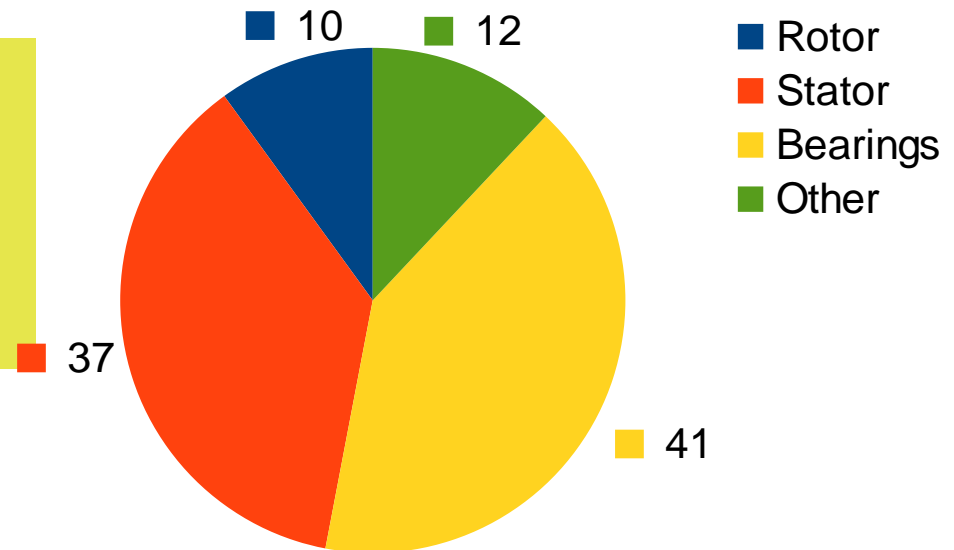

But, with proper maintenance, the majority of these issues can be virtually eliminated

# Bearing Lubrication Failures

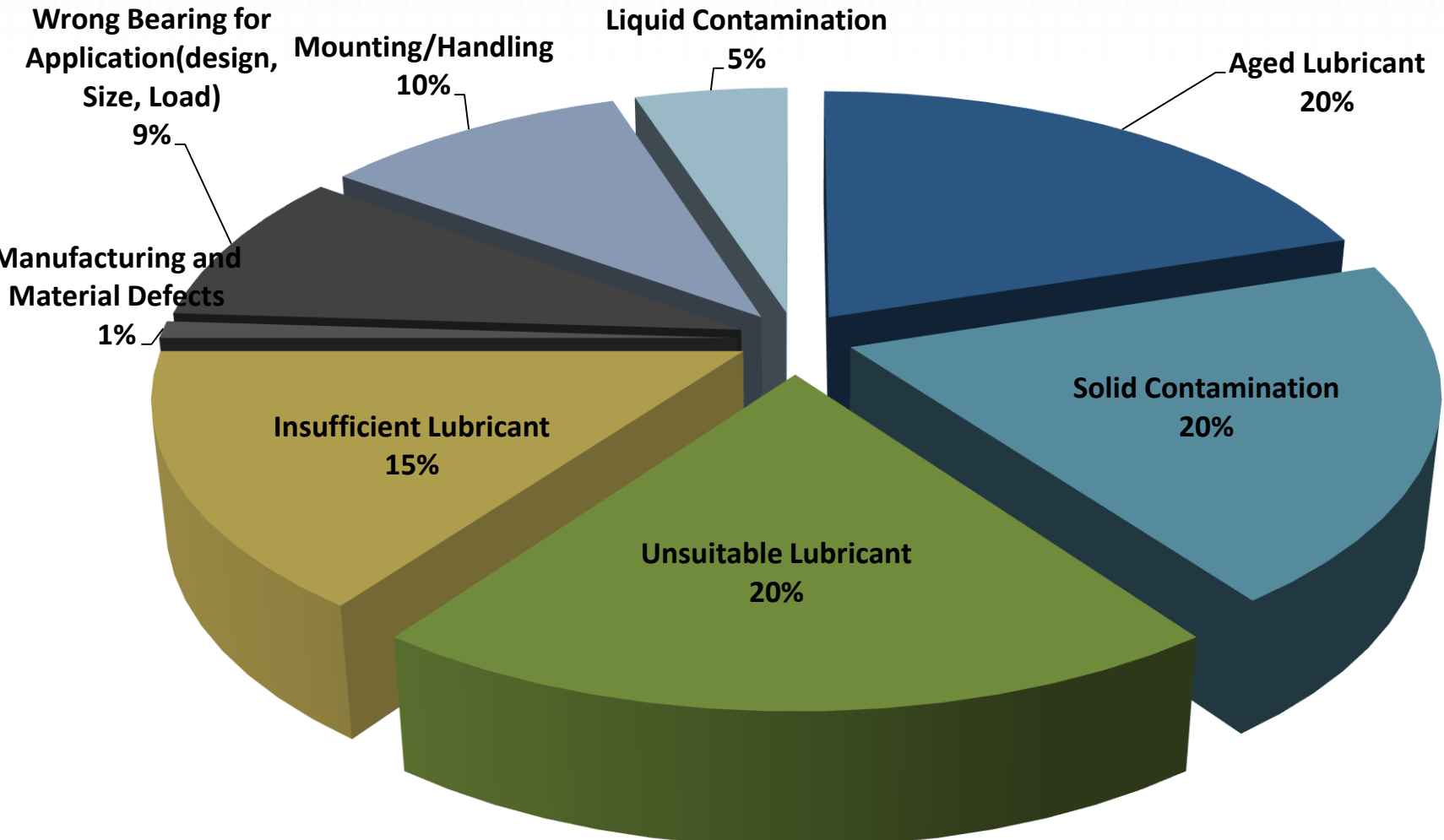

**(55% of all premature bearing failures are lubricant related)**

# AC Motor Components

# AC Motor Components

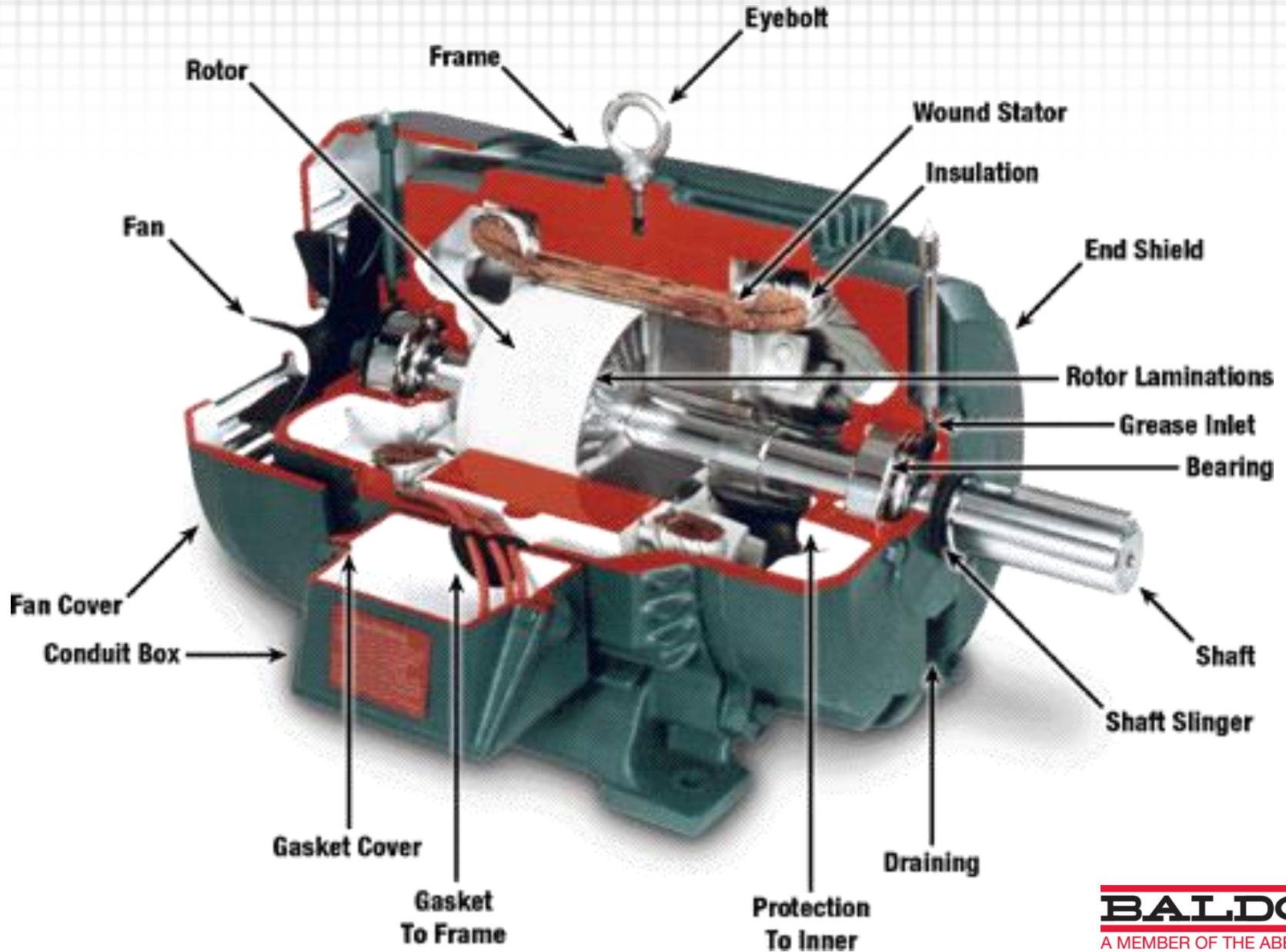



# AC Motor Components

## Above NEMA Frame AC Motors: Built for Reliable Performance

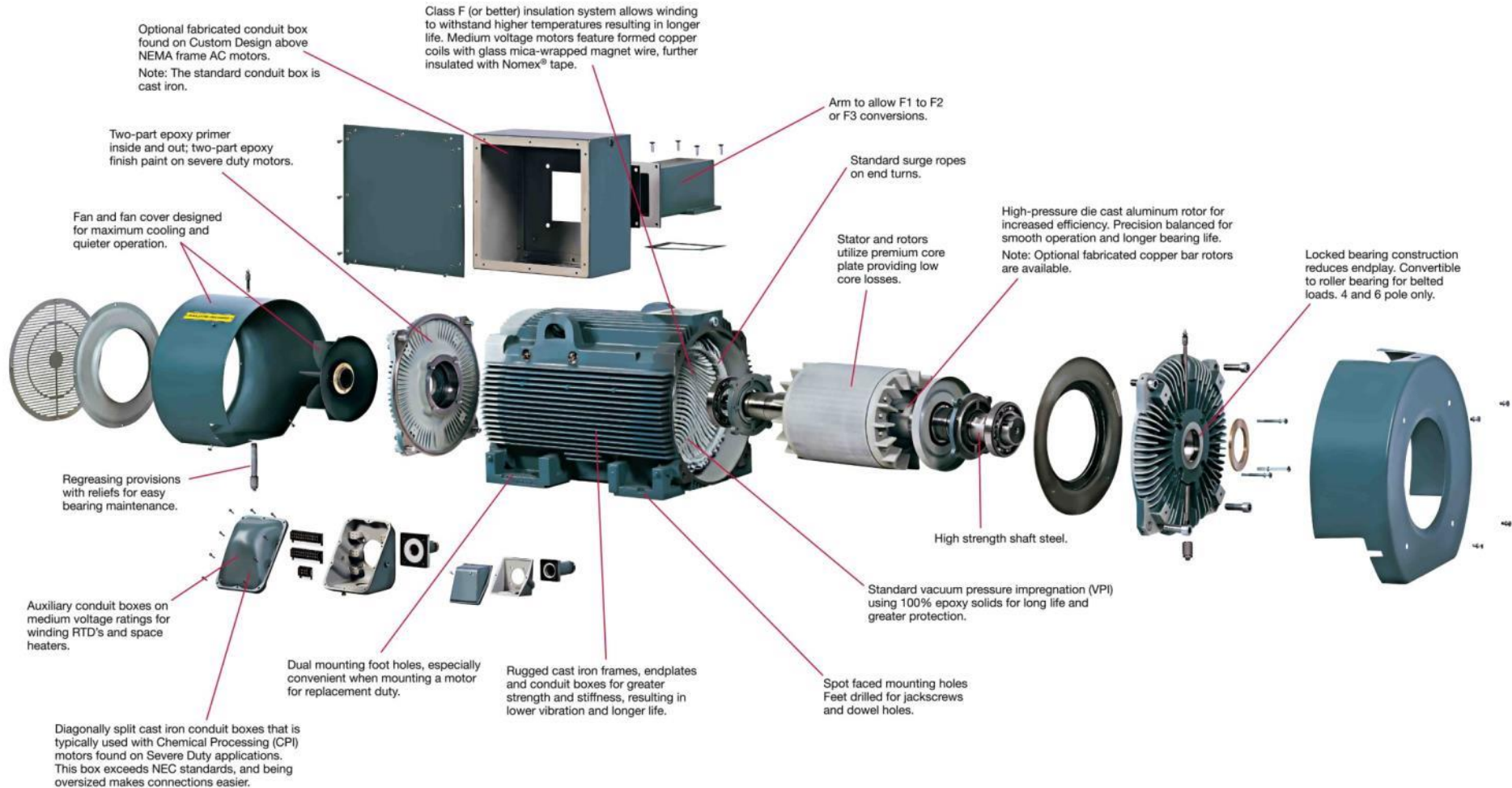

# Two Basic Parts of any AC Motor

- Stator - contains windings in electrical steel – and is pressed into the frame of motor
- The stator is not mechanically connected to the load
- Rotor and Shaft - rotating unit mounted on bearings and provides mechanical power transmission
- The rotor and shaft are mechanically connected to the load



# What is Electrical Steel?

- A special cold rolled steel with an insulating coating on both sides (also called lamination steel).
- It has relatively low losses (in a motor this is called core loss).
- Mixture of ~ 3- 6% silicon.
- Very efficient at generating/concentrating magnetic fields per given current flow.

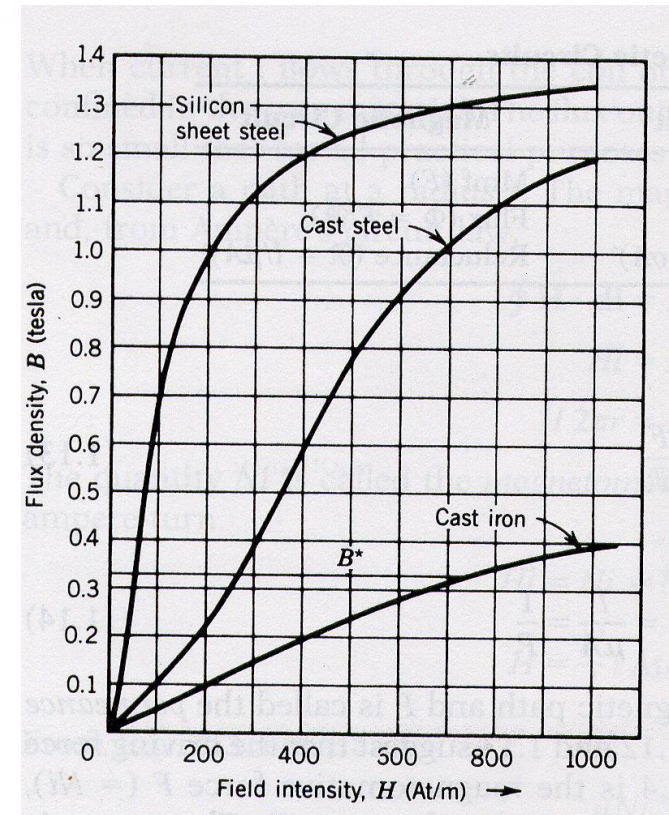

# Why use Laminations?

- Eddy currents are induced in any conductor when rotated in magnetic field.
- These currents are affected by the resistance of the material.
- Laminations must be insulated from each other to minimize losses.
- The electrical steel has a special inorganic coating which insulates each lamination from each other.
- Optimizing the design, metal & mfg. process is critical to performance.

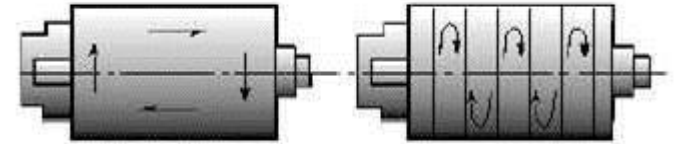

## Solid Core

Low resistance  
Large eddy currents  
Higher core losses

## Laminated Core

High resistance  
Small eddy currents  
Lower core losses

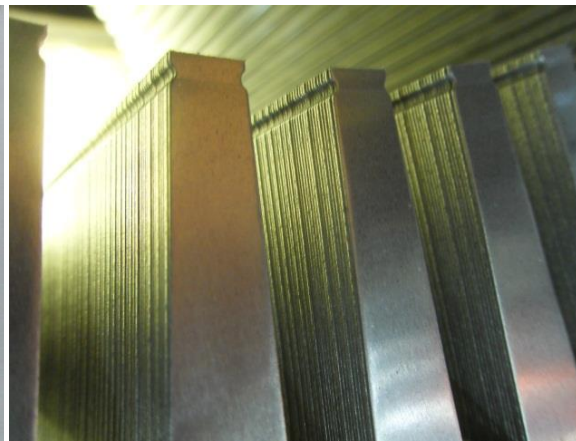
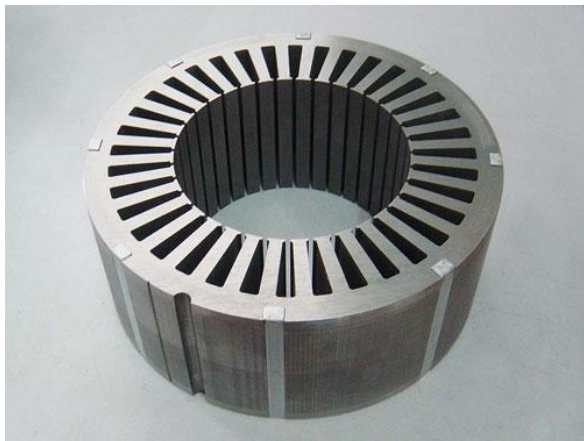
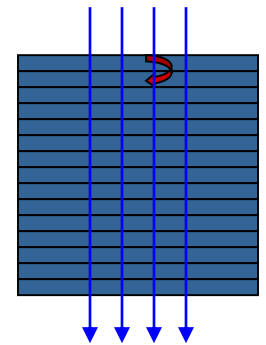
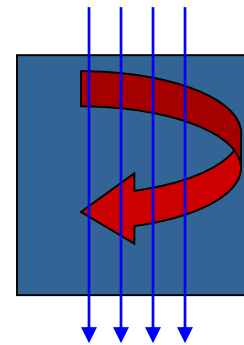

# Stator Construction

- The stator and rotor laminations are stamped from rolls of electrical steel.
- The stator laminations are stacked and then welded together to form a solid mass.



# Stator Cores

- Stator cores are manufactured in two basic types.
- Solid cores are used in TEFC motors.
  - › Cooled by heat transfer to the cast iron frame.
- Ducted cores are used in open motors (DPG, WP11) and in large enclosed motors such as TEAAC and TEWAC.
  - › Cooled by air circulation through the core ducts.

Solid



Ducted

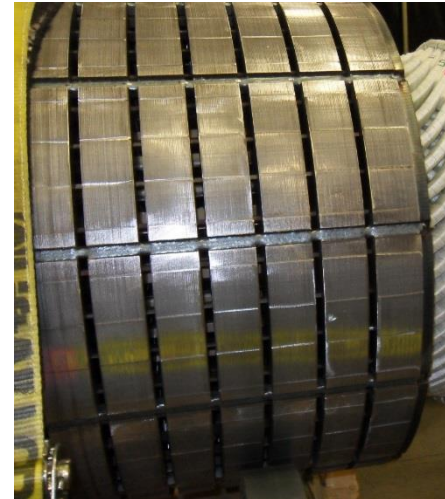

# Motor Stator Windings

- Stator windings create the rotating magnetic field required to make the shaft turn.
- A complete insulation system approach is required to protect the winding from damage due to:
  - › Movement – vibration causes friction that can create shorts in the wire.
  - › Heat – The hottest spot in the motor is in the stator slots. Insulation thermal breakdown can cause shorts.
  - › Electrical – Voltage spikes and high phase to phase potential differences can breakdown insulation and cause shorts.

# Types of Windings – Random Wound

- Random wound.
  - › Round magnet wire is formed into coils.
  - › Is called ‘random wound’ because the positioning of the wires is random.
  - › The first turn of a coil may be adjacent to the last turn.
  - › This type of winding is typically used for voltages <math><1000\text{VAC}</math>.

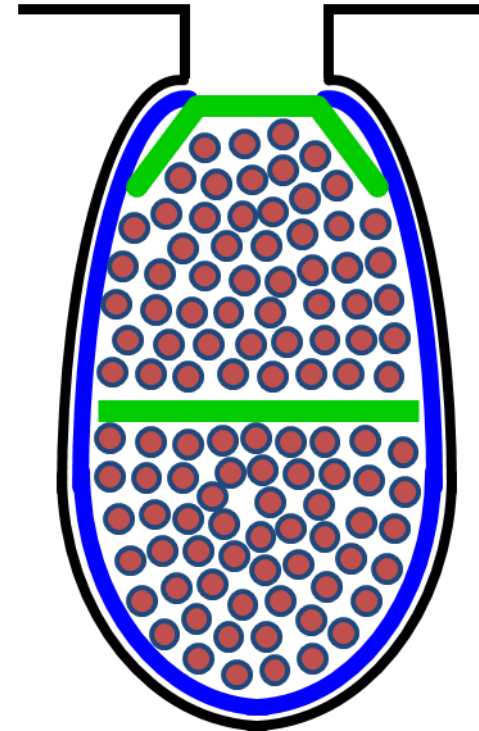



# Random Winding Construction

- Coils are wound in pole groups.
- Slot liners are installed.
- Pole groups are inserted into the stator.
- Phase paper is installed.
- Slot wedges are installed.
- Pole groups are connected to form phase groups.
- Leads are attached to phase groups.
- Winding is tightly laced together.



# Random Winding Construction

Key random winding components include:

- Slot liners – Nomex paper
- Random wound coils
- Slot wedges – Nomex paper
- Phase paper – Nomex paper
- Lacing
- 100% solids epoxy resin
  - › Dipped and baked
  - › Vacuum Pressure Impregnated



# Types of Windings – Form Wound

- Form wound.
  - › Rectangular wire is formed into coils.
  - › Is called ‘form wound’ because the coil shape must be formed to fit the stator slots.
  - › The positioning of the wires is sequential – the first turn of a coil is adjacent to the second, the second turn is adjacent to the third, etc.
  - › This type of winding is typically used for voltages >1000VAC.
  - › Is sometimes used on large motors at lower voltages.

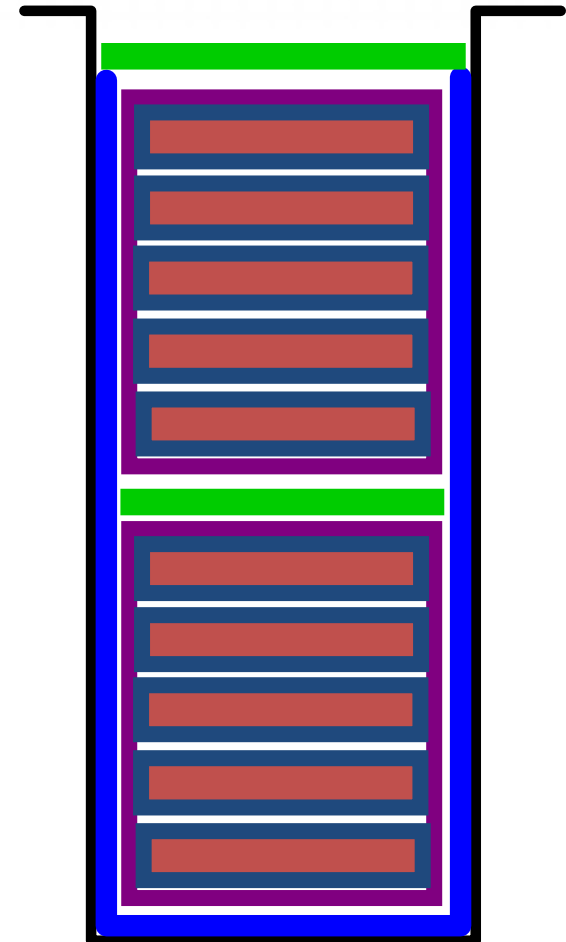

# Form Winding Construction



- Individual coils are wound in 'racetrack' oval shape.
- Coils shape is formed by machine.
- Coils are taped to provide ground wall insulation.



# Form Winding Construction

- Slot liners are installed.
- Individual coils are inserted into the stator.
- Individual coils are series connected to form pole groups.
- Pole groups are connected to form phase groups.
- Leads are installed.
- Blocking is installed.
- Surge rope or insulated metallic surge ring is tightly laced to the winding.



# Form Winding Construction

Key form winding components include:

- Slot liners – Nomex paper
- Form wound coils
- Slot wedges –  
Fiberglass laminates
- Felt blocking between adjacent coils
- Coils laced to surge rope or insulated metallic surge ring.
- 100% solids epoxy resin
  - › Vacuum Pressure Impregnated



# Comparing form wound to random wound

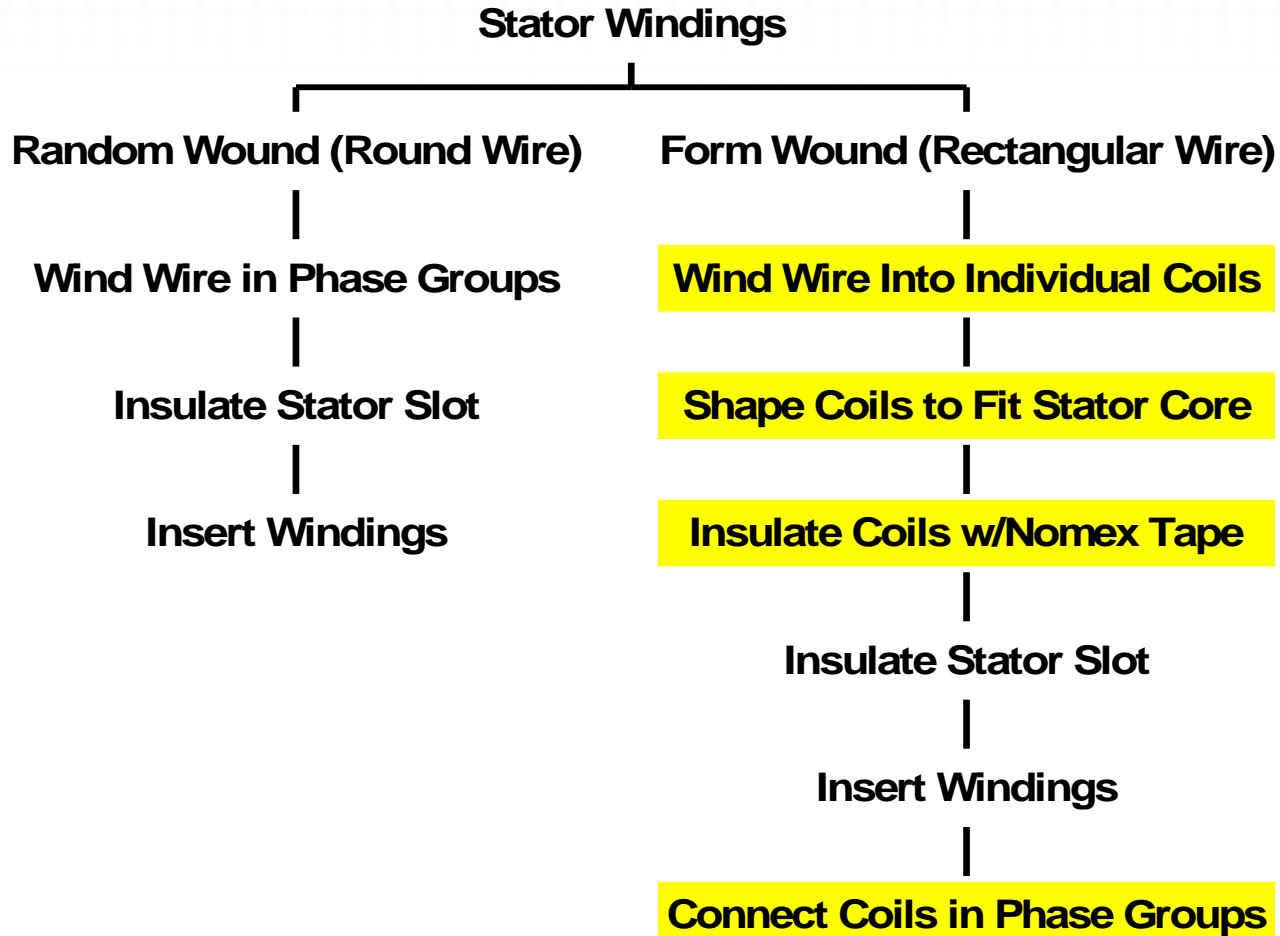

# Stator Varnish Treatment

- Stator varnish treatment seals the winding against contamination and provides mechanical strength to prevent vibration and movement. Varnish treatment can be applied by VPI or dip and bake process.





# Rotor Design: Cast Vs. Bar

## ■ Cast Rotor

- › Rotor Bars in intimate contact with laminations (Excellent Heat Dissipation)
- › Wide Variety of Slot Shapes Possible for Various Speed/Torque Characteristics

## ■ Bar Rotor

- › Rugged Construction
- › More Expensive
- › Repairable
- › Different Alloys , Different Speed/Torque Characteristics
- › Better for applications requiring a high number of starts – typically longer life

# Rotor Design: Solid Rotors

- Used on TEFC motors and some open motors.
- Cooling through surface convection.

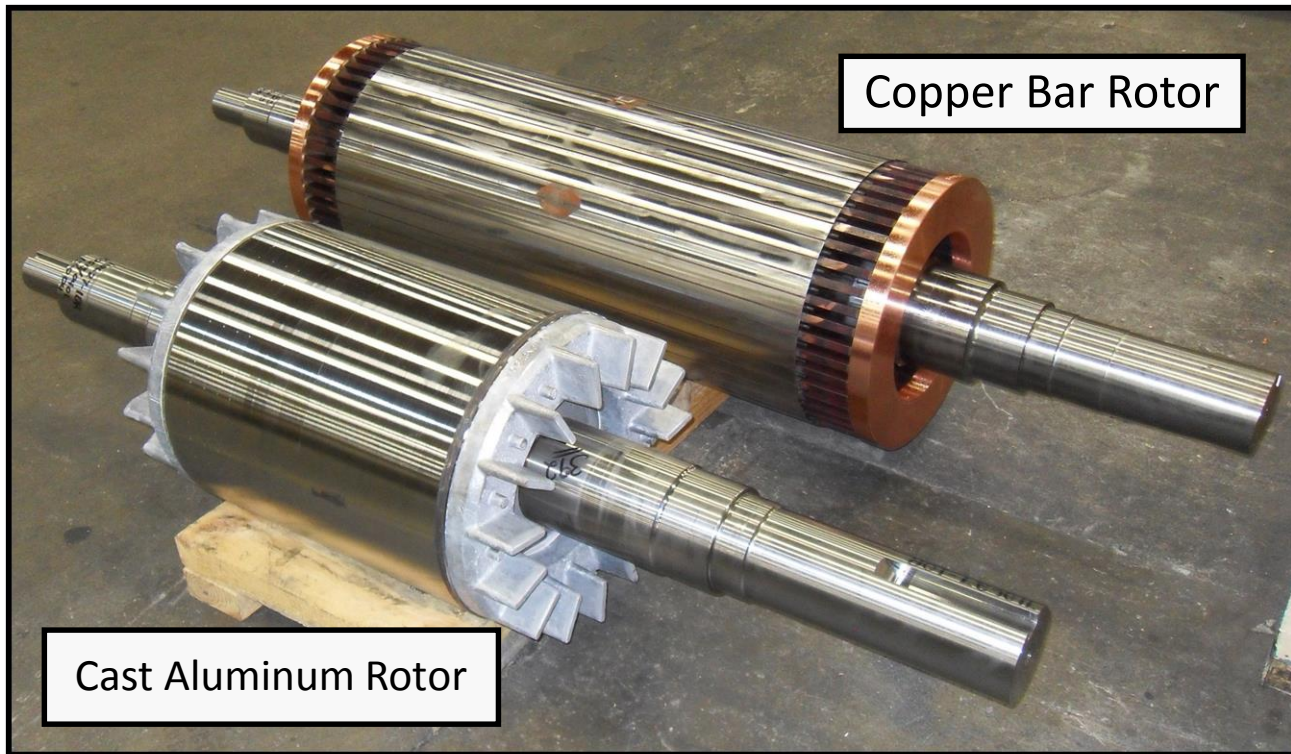

# Rotor Design: Ducted Rotors – Cast Aluminum

- Used on open motors
- Cooling provided by air flow through ducts
- Air flows into axial ducts
- Air flows out of radial ducts
- Integral cast fans
- Integral cast balancing sprues
- Integral cast end rings

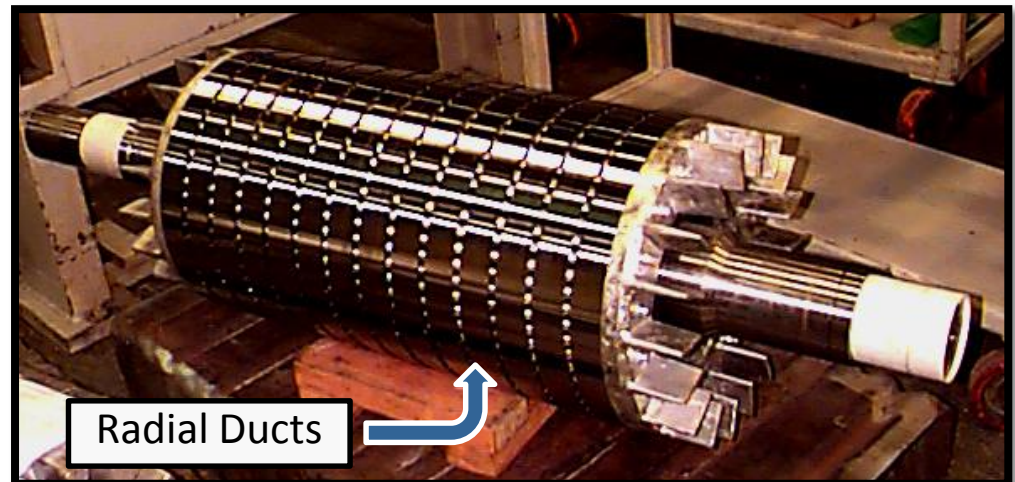
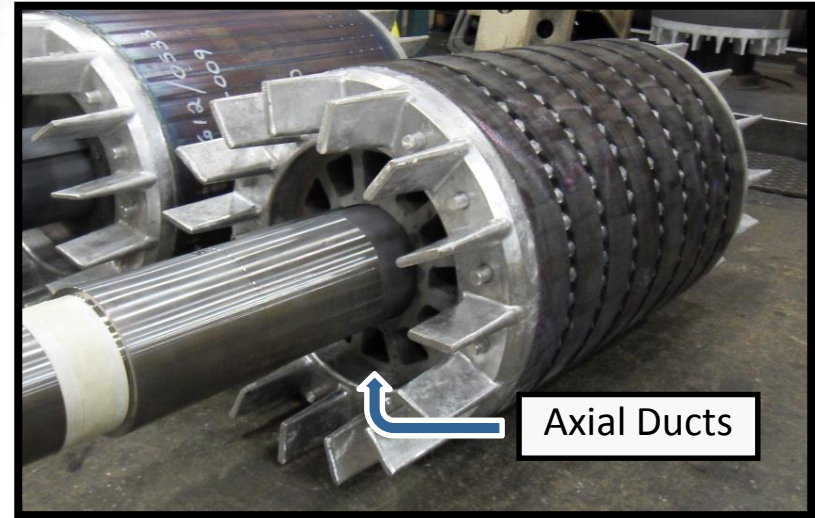

# Rotor Design: Ducted Rotor – Copper Bar

- Used on open motors
- Same cooling method as ducted cast rotor
- Separately manufactured cooling fan

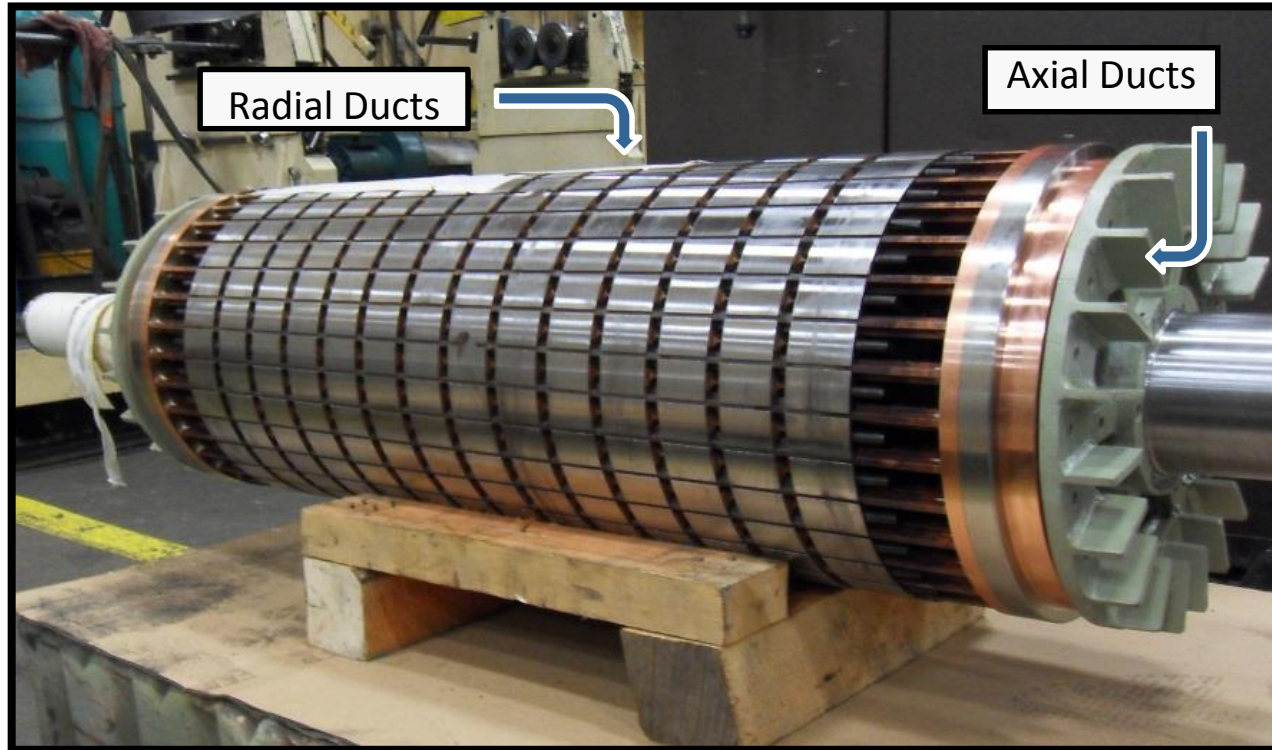

# Cast Rotor Construction

- Laminations and end ring molds are stacked on an arbor to form a tooling assembly.
- Completed tooling assembly is placed in a oven for preheating.
- Preheating ensures quality castings by reducing thermal stress and voids during the casting process.

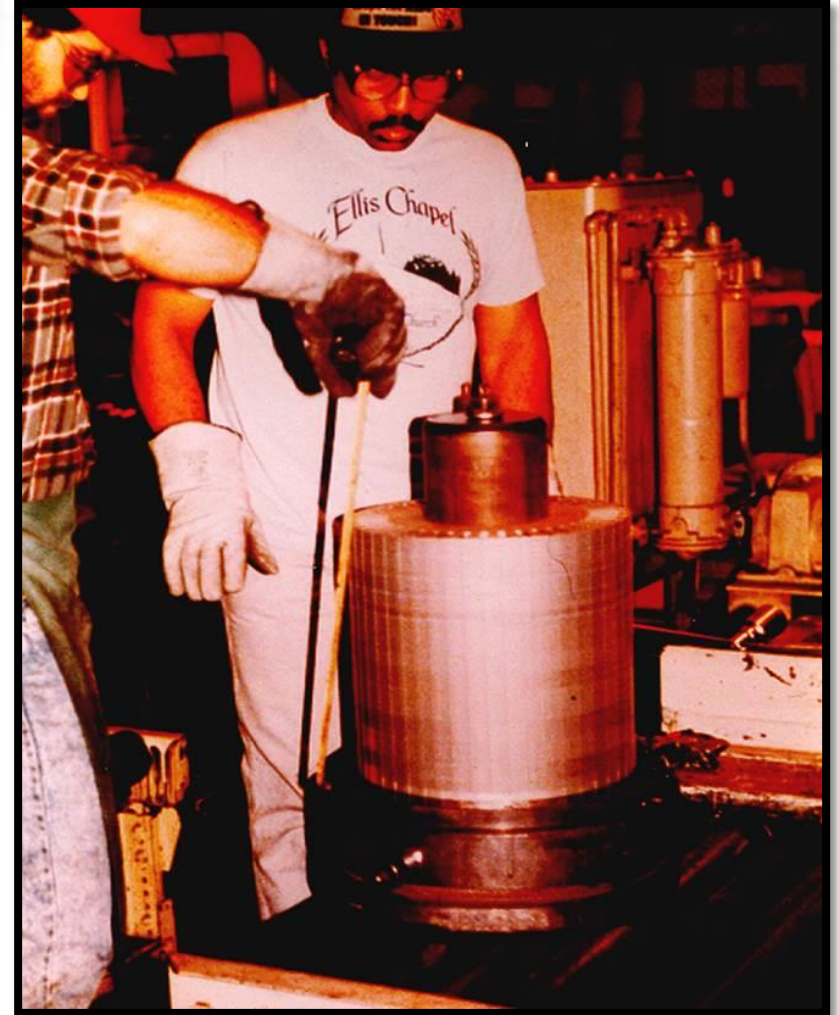

# Cast Rotor Construction

- Molten aluminum at over 1200 ° F is poured into the shot well in the bottom of the casting machine.
- The tooling assembly is then placed over the well and pressed together.
- The casting machine door is closed and the aluminum is injected under pressure into the tooling assembly.
- Vent holes in the top of the mold allow for escape of gases.

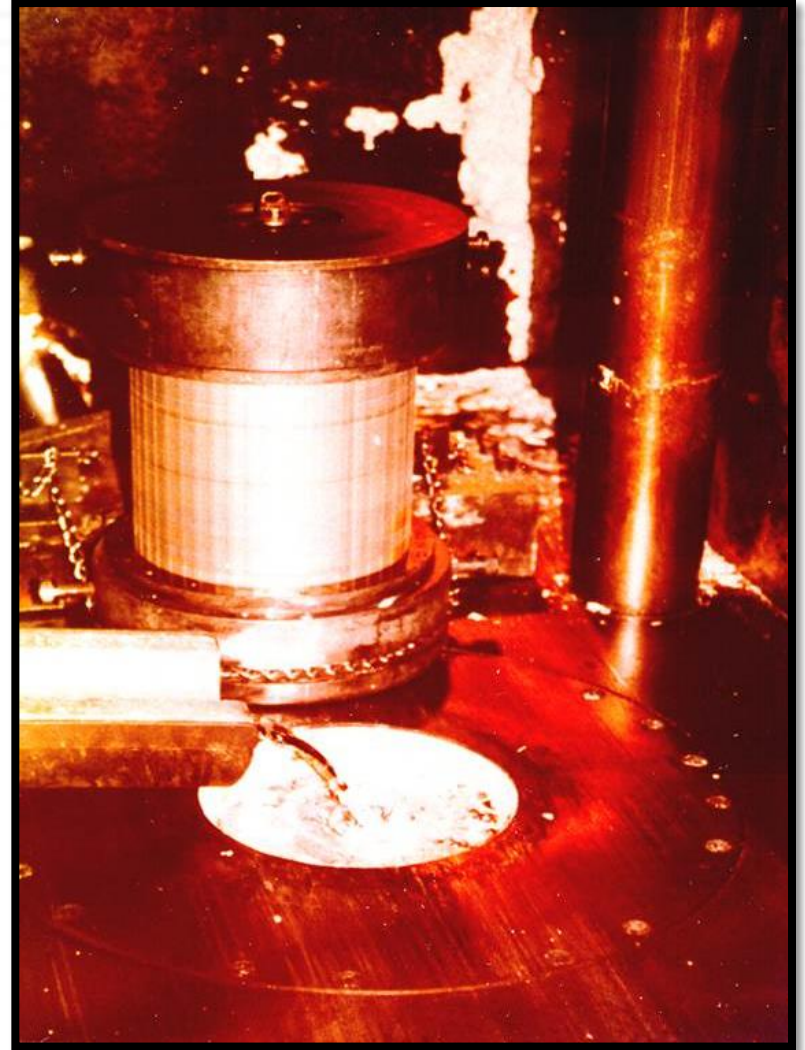

# Cast Rotor Construction

- The tooling assembly is removed from the casting machine and the lower and upper molds are removed.
- At this point the core is now held together by the bars and end rings which are cast into one continuous piece.
- The extra aluminum or flashing is then removed from the rotor by using a file or hand grinder.



# Copper Bar Rotor Construction

- Basic components are short circuit rings, bars, and laminations.

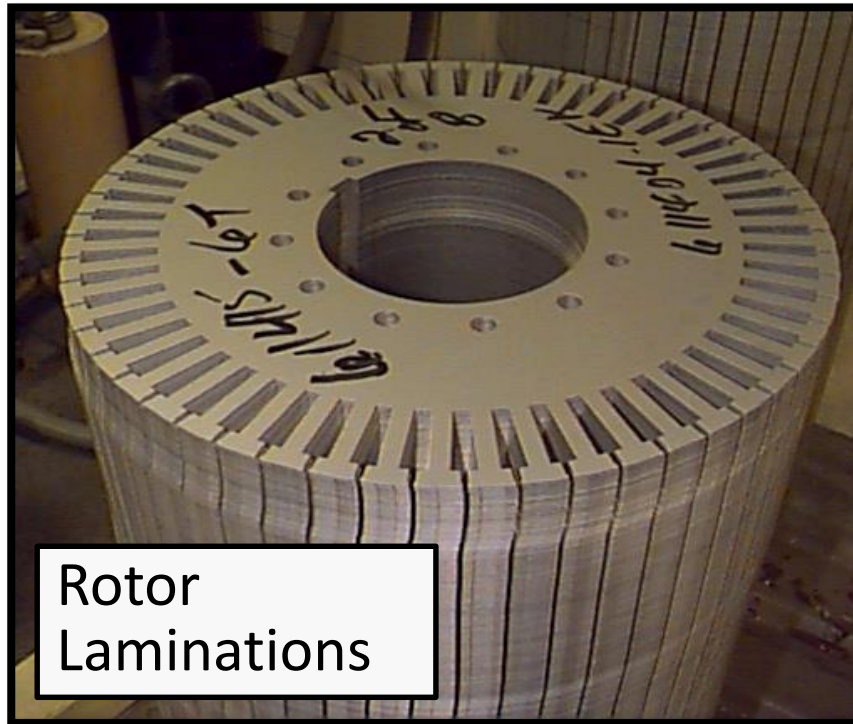

Rotor Laminations

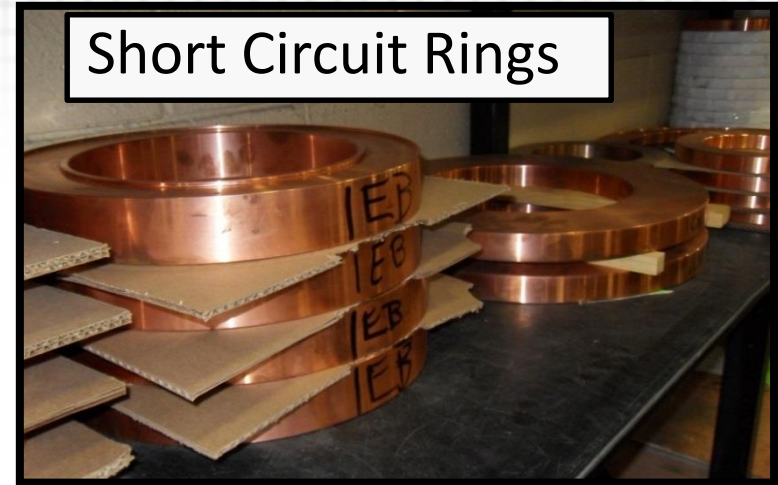

Short Circuit Rings

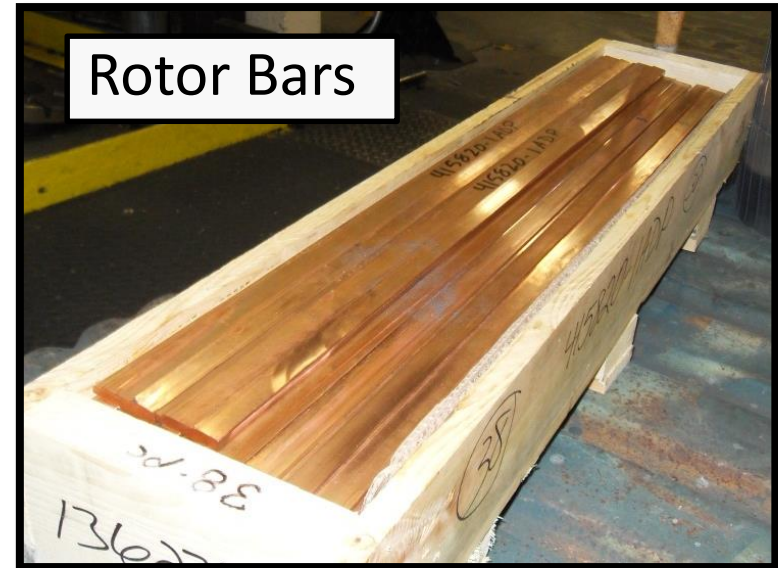

Rotor Bars



# Copper Bar Rotor Construction

- Laminations are stacked on an arbor.
- End plates are installed.
- Lamination stack is put under pressure.
- Studs are installed and torqued to hold lamination stack together.

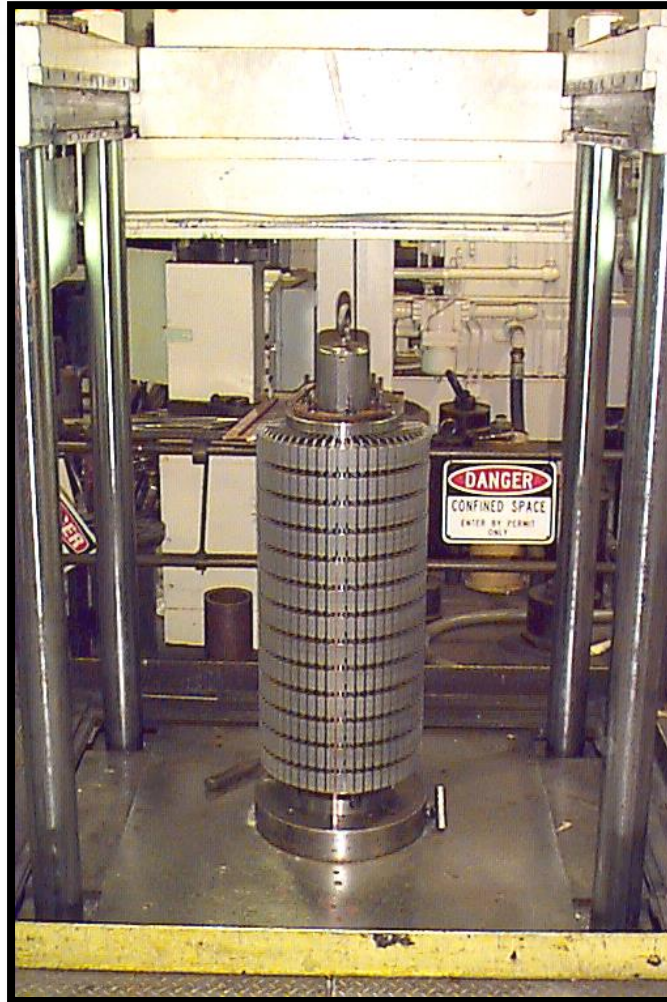

# Copper Bar Rotor Construction

- Rotor bars are inserted into the lamination stack and pinned into place.

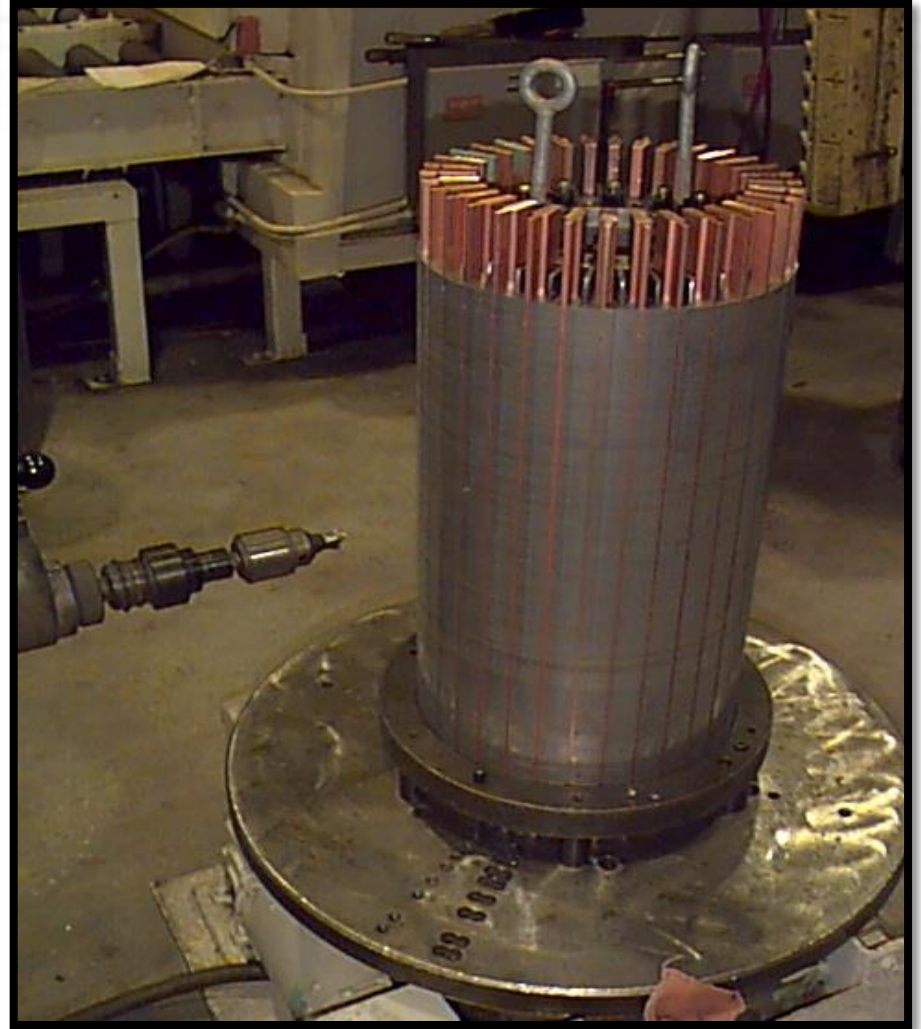

# Copper Bar Rotor Construction



- The rotor is placed on a rotating base.
- Flux and silver solder is placed in the end ring.
- Multiple torches combined with the rotating base ensure uniform heating.



# Rotor and Shaft Assembly

- Rotor core is heated.
- Shaft is dropped/pressed into rotor core.
- Assembly is allowed to cool vertically.



# Rotor and Shaft Assembly

- Rotor is turned in a lathe to exact size and concentricity.
- Rotor is balanced to specification.

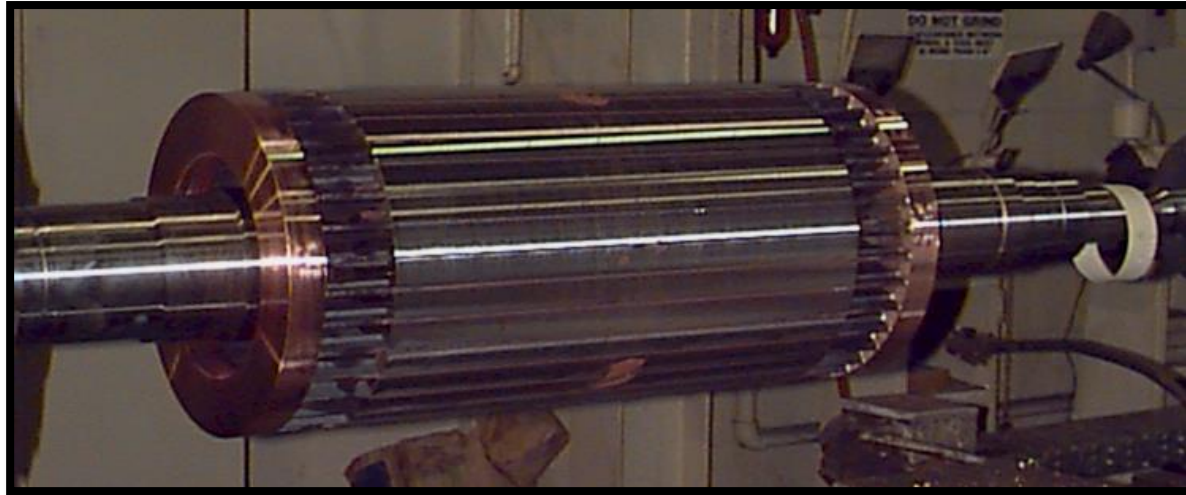

# Rotor and Shaft Assembly

- After balancing the rotor assembly is painted to provide corrosion resistance.

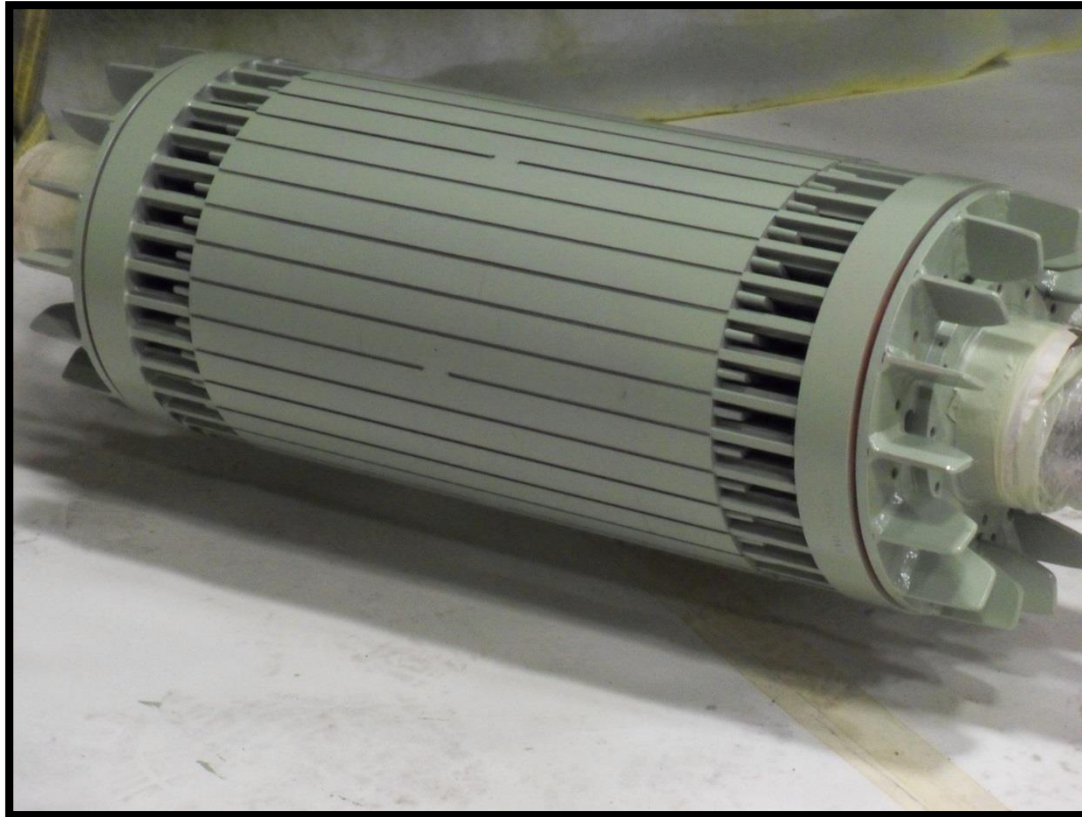

# Motor Bearings

- The purpose of motor bearings is to:
  - › support and locate the rotor.
  - › transfer thrust and radial load from the shaft to the motor frame.

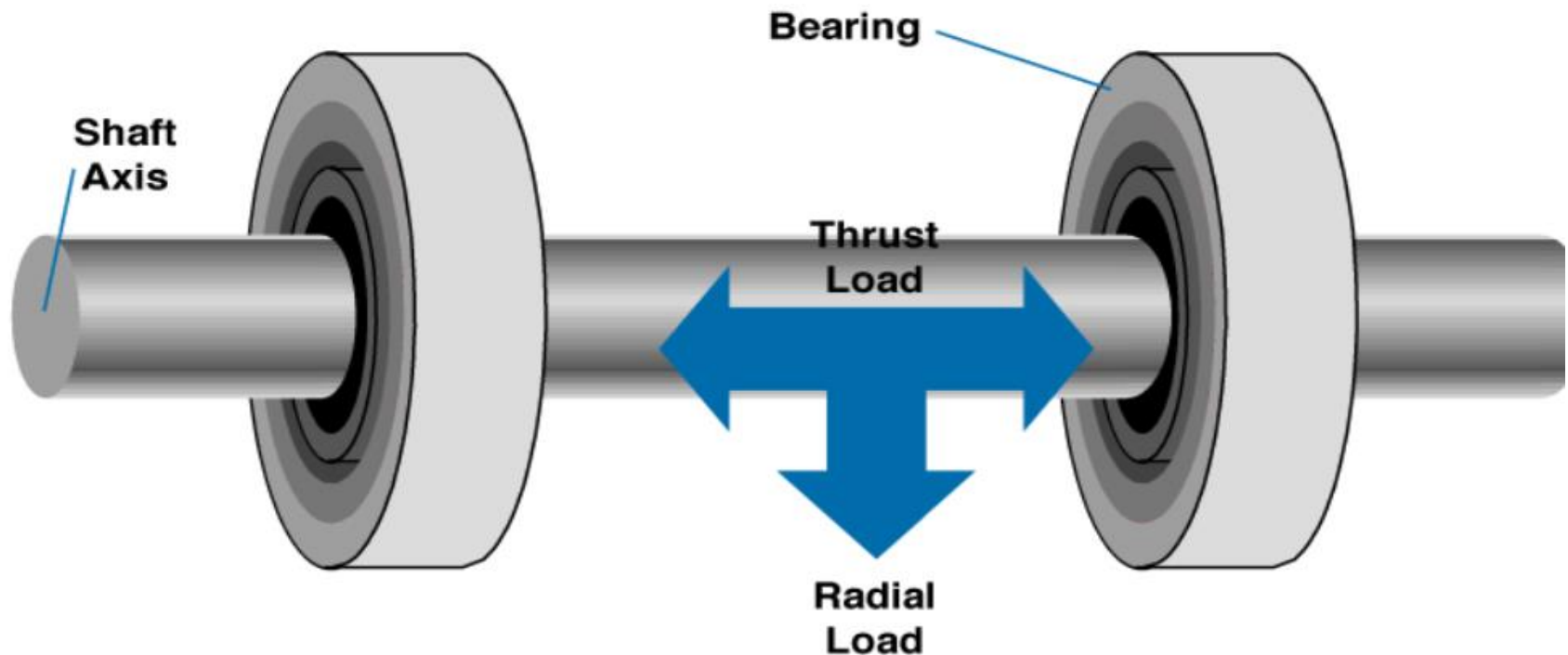

# Motor Bearings – Antifriction Bearings

- Constructed of rolling elements located between an inner and outer race.
- Usually made of hardened steel.
- Can be grease or oil lubricated.
- Are inexpensive.
- Have a finite life.
- Also known as ball or roller bearings.





# Antifriction Bearings

## Locating and non-locating bearings

- Locating bearing
  - › Positions the shaft
  - › Supports axial loads
- Non-locating bearing
  - › Accommodates thermal expansion

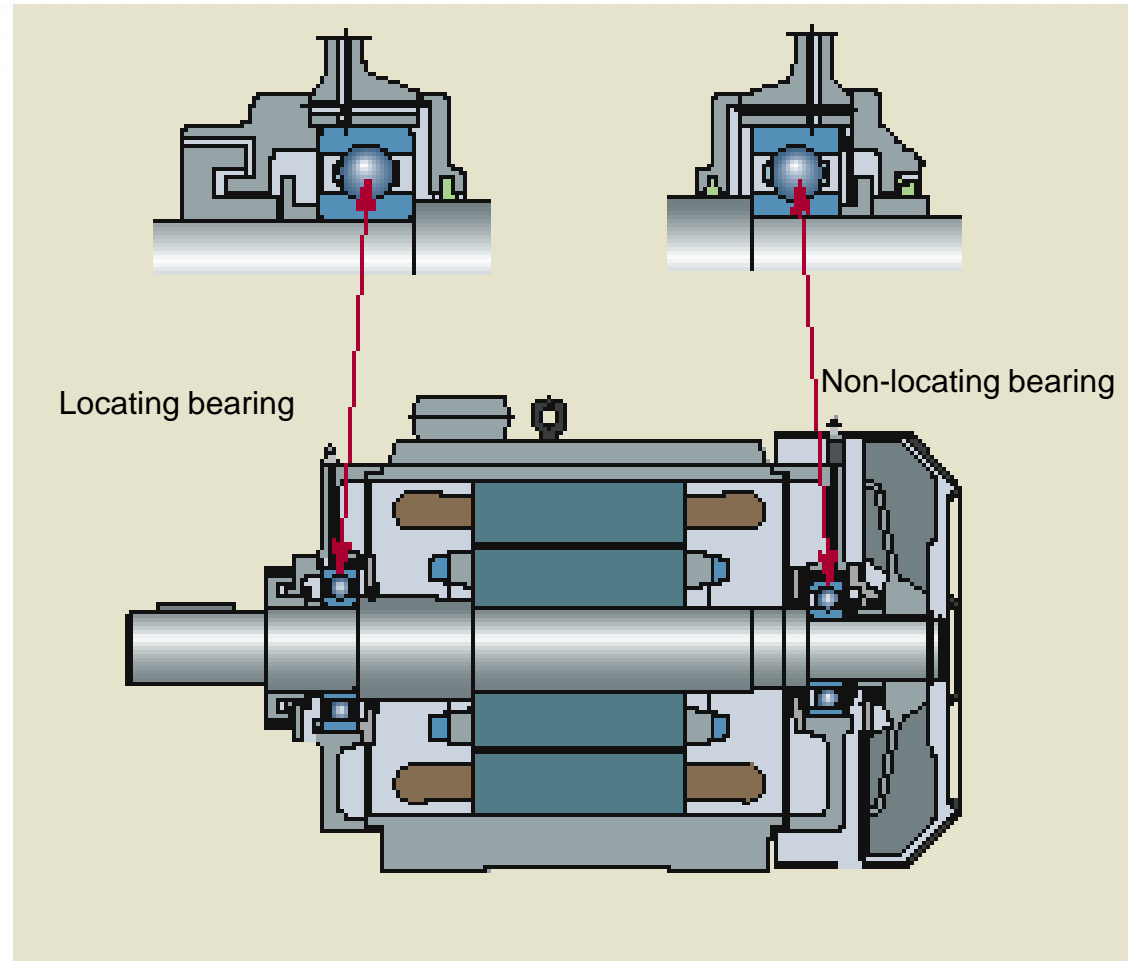

# Antifriction Bearings

## Direct coupled, low to normal load

- Two Deep Groove Ball Bearings
- Low maintenance solution
- The locating bearing is on the drive end
- The non-locating bearing is spring loaded (NDE)

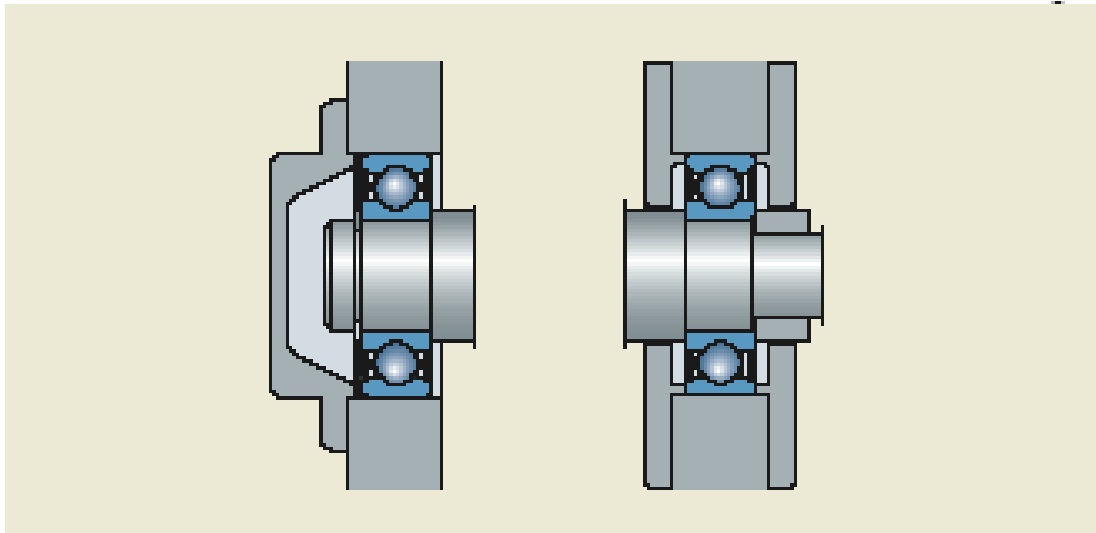

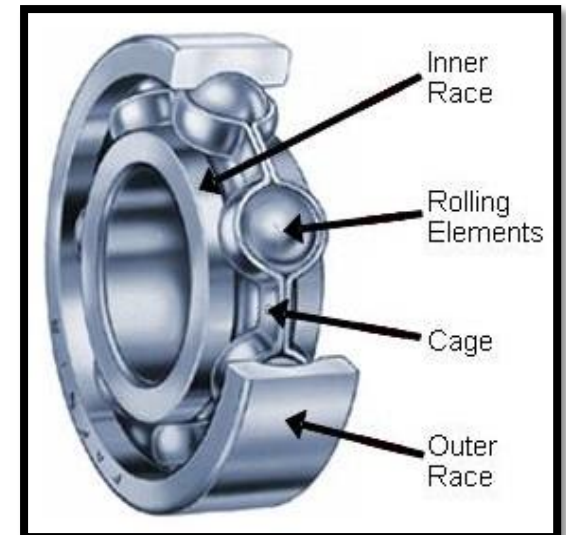

	<u>Geometry</u>	<u>Point of Contact</u>
Ball		



# Antifriction Bearings

## Belt Drive (Radial Load)

- Roller bearing on drive end
- Ball bearing on non-drive end
- The locating bearing is the non-drive end

	<u>Geometry</u>	<u>Point of Contact</u>
Cylindrical Roller		

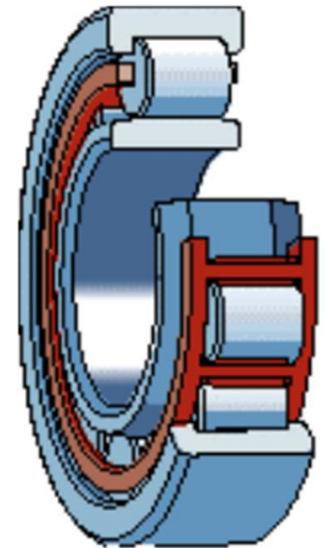
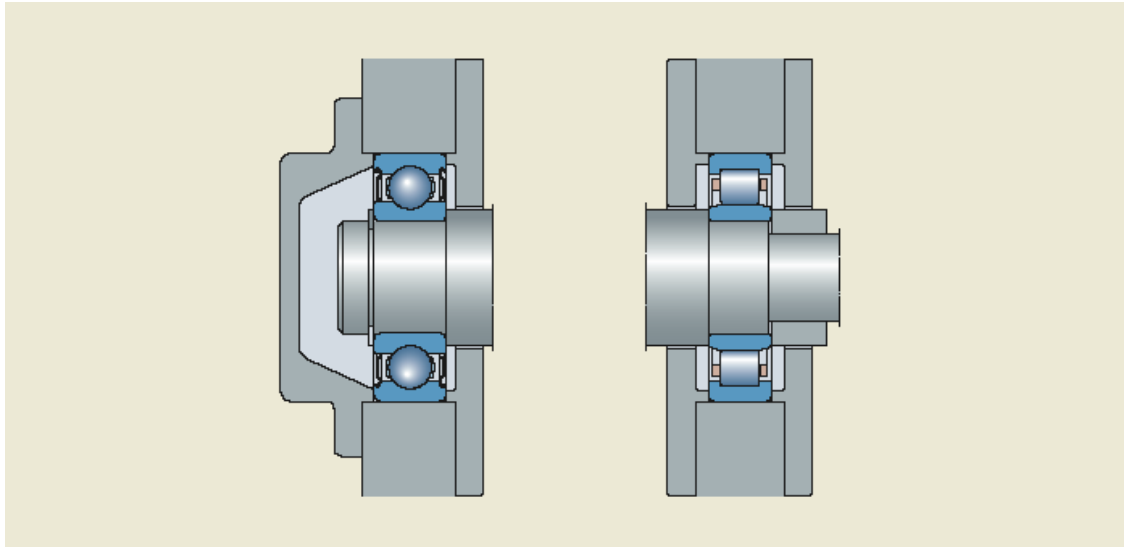

# Antifriction Bearings

## Vertical – light thrust loading

- Ball bearings both ends
- Small axial loads in both directions
- The upper bearing is spring pre-loaded

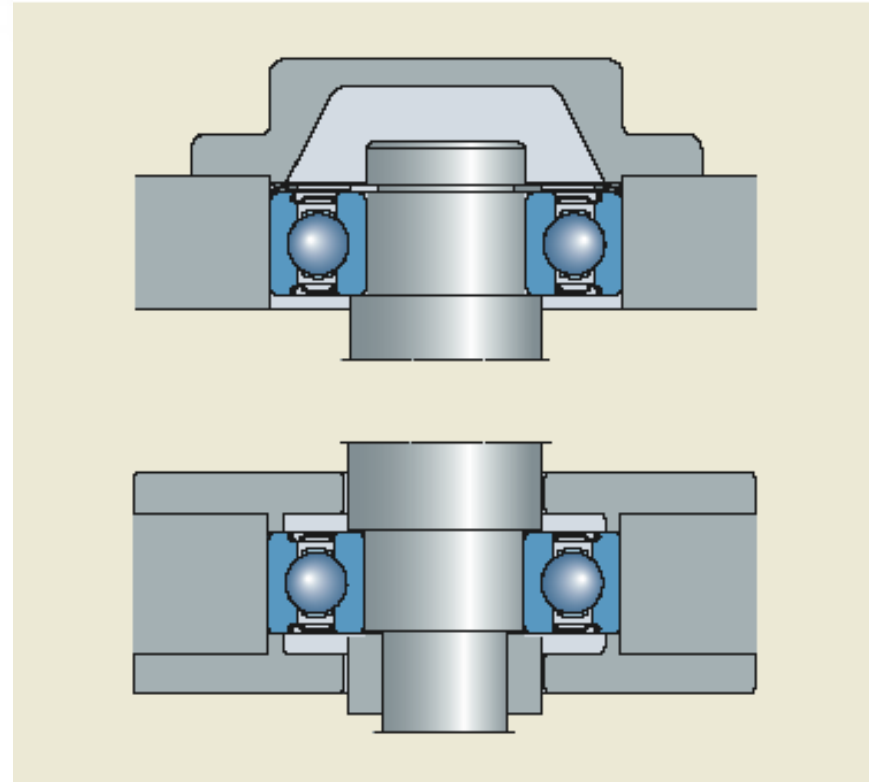

# Antifriction Bearings

## Vertical – medium to high thrust

- Angular contact thrust bearings
- Ball guide bearing
- Moderate axial loads in both directions with back to back arrangement
- Heavy axial load in one direction with tandem arrangement
- Lower bearing is spring loaded

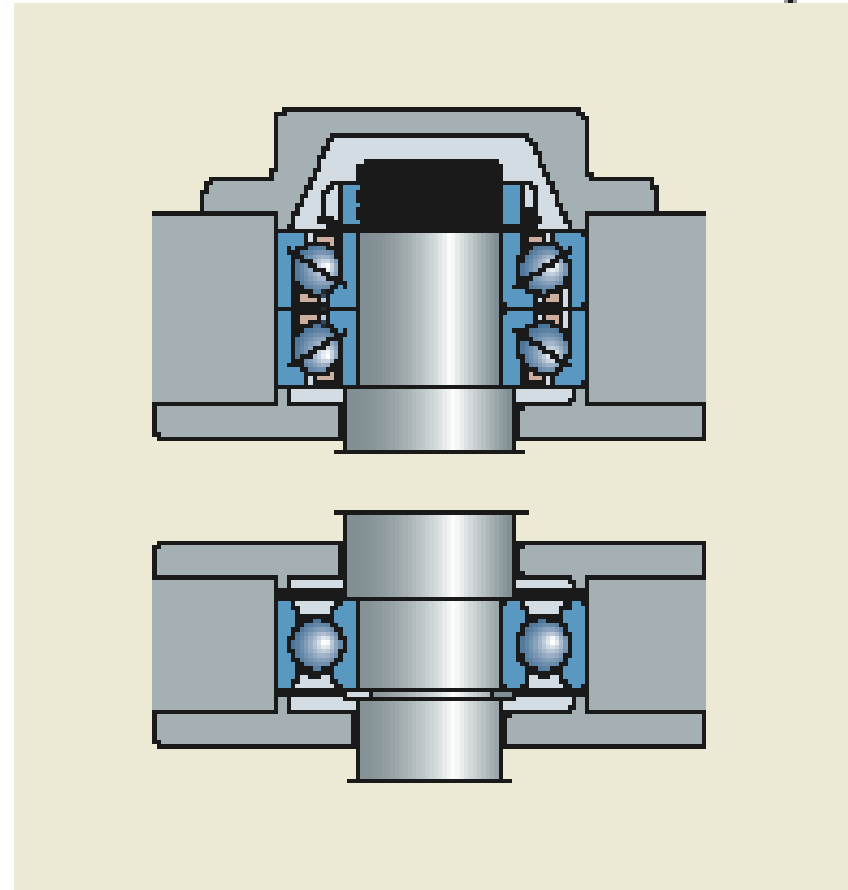

# Antifriction Bearing Lubrication

## Primary functions:

- To reduce friction by lubricating the sliding contacts within a bearing, i.e., cages, flanges, raceways, etc.

## Secondary functions:

- To protect the highly finished surfaces from corrosion
- To help seal against foreign matter (with grease pack)
- To provide a heat transfer medium.

# Antifriction Bearing Lubrication

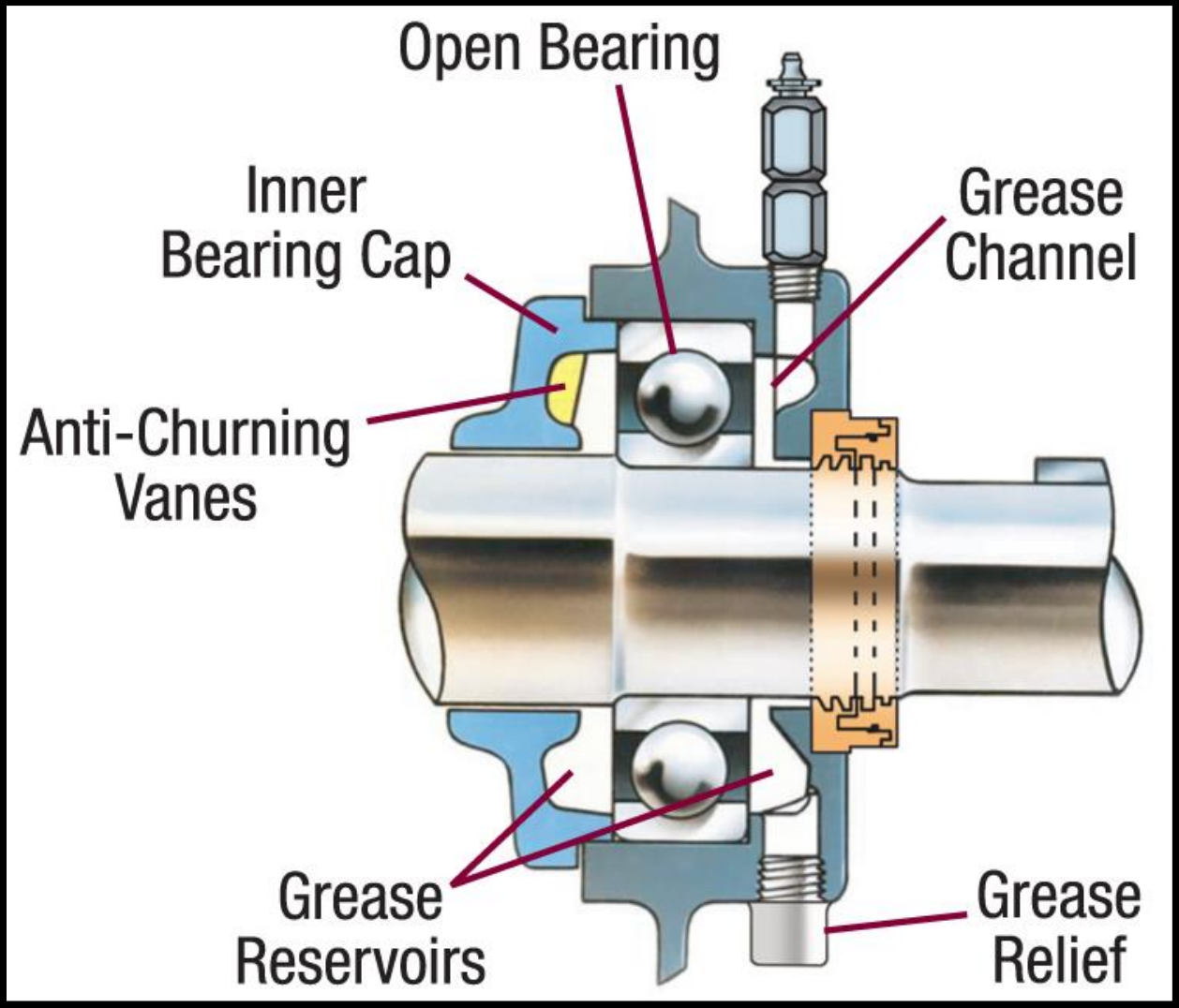

# Antifriction Bearing Lubrication

## Advantages

- Easy to apply
- Wide range of applications
- Easy to prevent leakage

## Disadvantages

- Poor heat dissipation
- Collects and retains contaminants
- Requires frequent relubrication
- Possible compatibility problems if greases are mixed

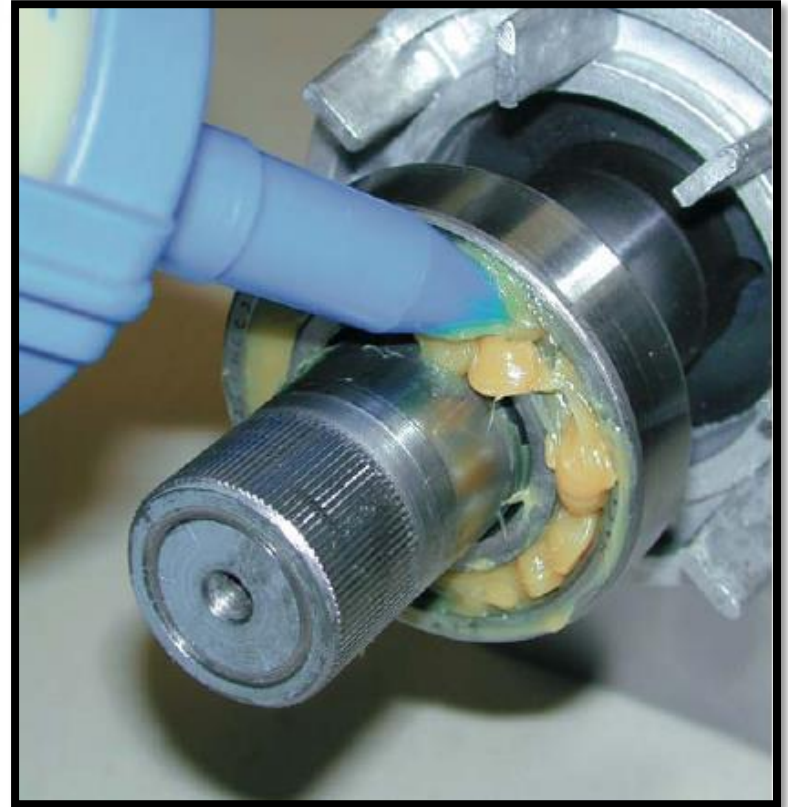



# Antifriction Bearing Lubrication

- Factors Influencing Grease Life & Re-lubrication Interval
  - › Bearing type, size, and design
  - › Operating Conditions (hrs/day, shock loading, vibration)
  - › Environment (contamination, humidity, temperature)
  - › Grease performance

Table 3-1 Service Conditions			
Standard Conditions	Eight hours per day, normal or light loading, clean ambient air at 40°C (100°F) maximum		
Severe Conditions	Twenty four hours per day operation or shock loading, vibration, ambient air containing dirt or dust at 40-50°C (104-122°F)		
Extreme Conditions	Heavy shock or vibration, ambient air containing dust, dirt or high humidity and temperature in excess of 40°C (104°F)		
Table 3-2 Relubrication Intervals			
Anti-Friction Bearings			
Speed (RPM)	Standard Conditions	Severe Conditions	Extreme Conditions
< 3,000	6 months	3 months	3 months
≥ 3,000	6 months	3 months	2 months
Roller Bearing			
< 3,000	3 months	1.5 months	1.5 months

# Antifriction Bearing Life

- The  $L_{10}$  life represents the life that 90% of an identical group of bearings will achieve before failure with identical running conditions.....
- Factors Affecting Life
  - › Contamination
  - › Improper Lubrication
  - › Application
  - › Misalignment
  - › Improper Installation
  - › Excessive Temperatures

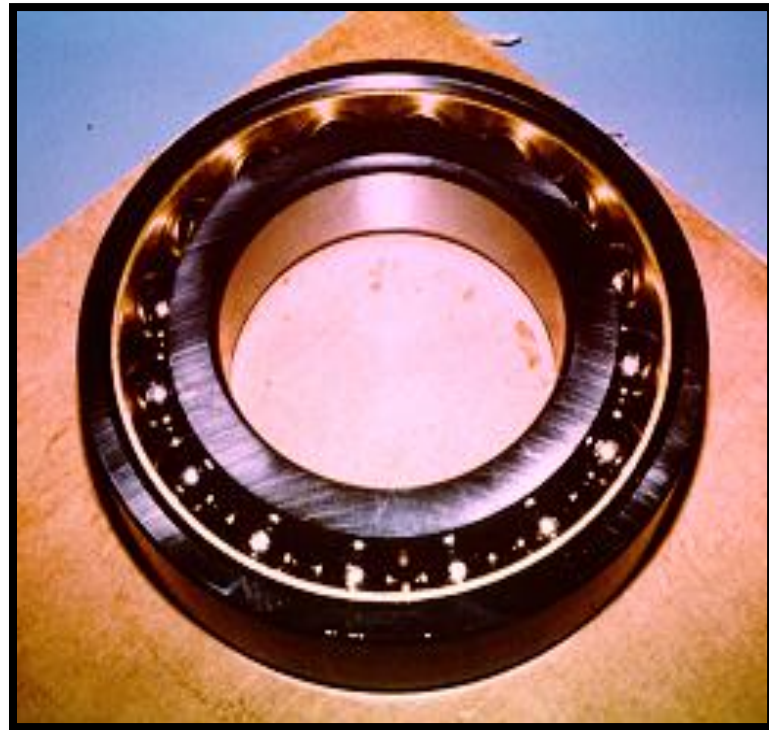

# Antifriction Bearing Life

$$L_{10} = \left( \frac{C}{P} \right)^p \quad (1)$$

$$L_{10h} = \frac{1000000}{60 \times n} \left( \frac{C}{P} \right)^p \quad (2)$$

$L_{10}$  = Basic Rating Life in millions of revolutions at 90% reliability ( $10^6$  revs).

$L_{10h}$  = Basic Rating Life in hours at 90% reliability (hr).

$C$  = Basic dynamic load rating (kN).

$P$  = Equivalent dynamic bearing load (kN).

$n$  = Operating speed (rev/min).

$p$  = Life exponent.

- Ball Bearings use 3
- Roller Bearings use 10/3

# Motor Bearings - Sleeve Bearings

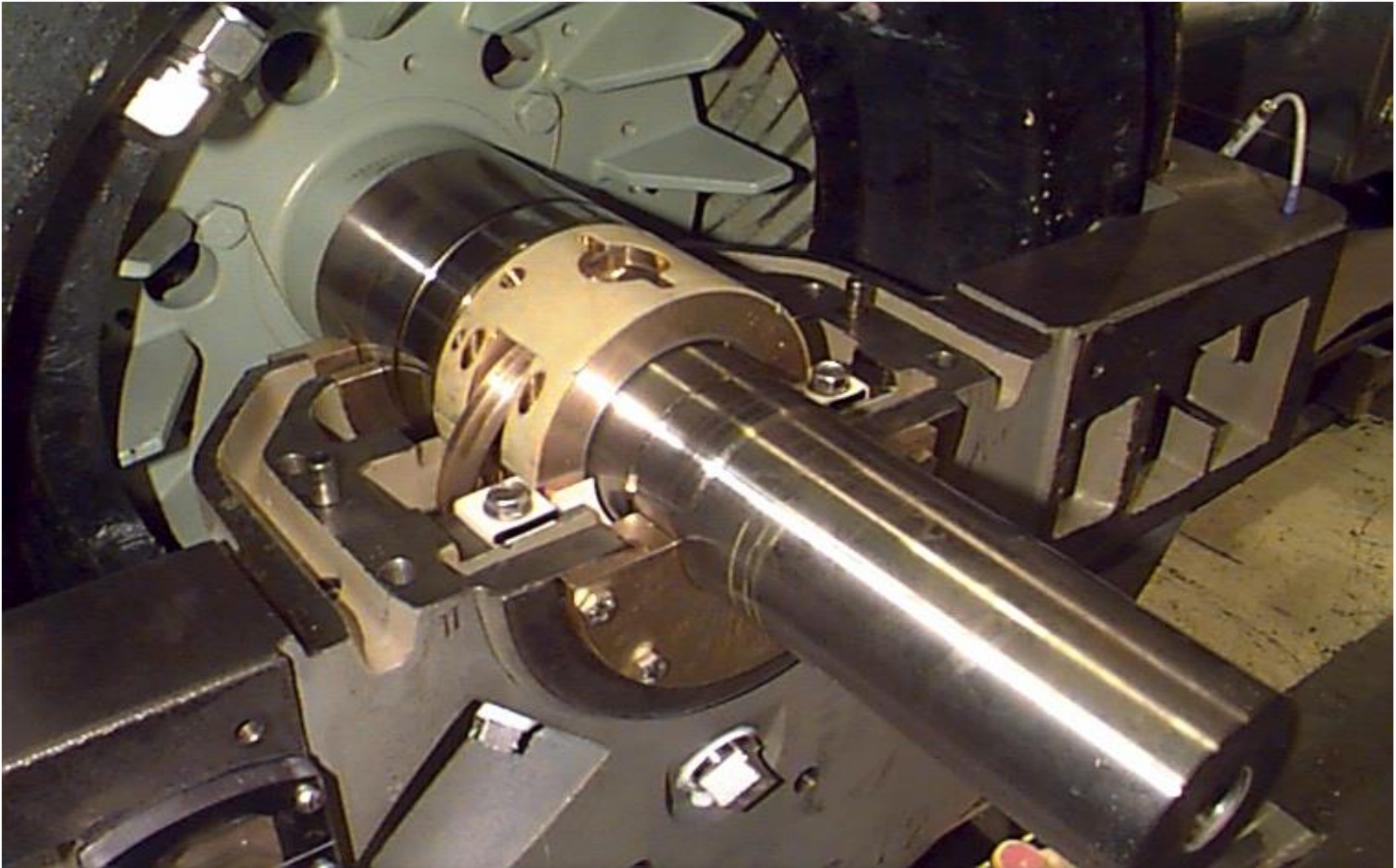

# Key Differences to Sleeve Bearings

- Sleeve journal bearings operate on the principle of hydrodynamic action.
  - › No rolling elements.
- As the shaft rotates, it builds up a wedge of oil between the bearing and shaft.
- The oil wedge supports the rotating shaft.
- Minimum operating speed required to maintain oil wedge.
- Theoretically infinite life.
- Also known as babbitt or hydrodynamic bearings.

# Sleeve Bearings – Plain Bore

- Horizontal applications.
- Most common type of sleeve bearing.
- Oil film builds up because of difference in bore size between shaft and liner.
- Bearing load is only taken in one direction vertically down.
- Oil ring lubricated.



# Sleeve Bearing – Plain Bore

- Bearing can support radial loads in multiple directions
- Can be used in horizontal applications or as guide bearing on vertical applications.
- No oil ring lubrication
  - › Must have separate forced lubrication system for horizontal applications.
  - › Requires oil bath lubrication for vertical applications.



# Sleeve Bearings – Self Aligning Horizontal Tilting Pad

- Rounded housing allows self alignment.
- Can carry radial load in multiple directions.
- Can optimized for unidirectional rotation by changing the tilting pad pivot point.
- Multiple oil wedges are created.
- No oil ring lubrication
  - › Must have separate forced lubrication system for horizontal applications.
  - › Requires oil bath lubrication for vertical applications.

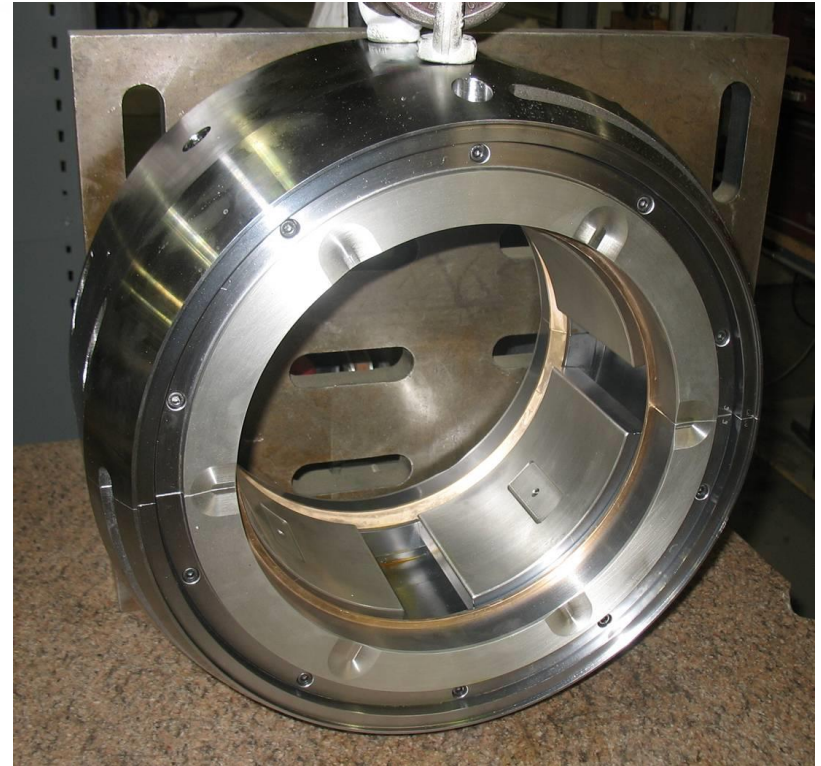



# Tilting Pad / Thrust Bearing Combination

- Bearing can support radial and axial (thrust) loads.
- Can carry radial load in multiple directions.
- Typically used in vertical pumps with high thrust.
- Oil bath lubricated.
  - › Under high speeds and loads, oil will need to be cooled by heat exchanger.
- Can be optimized for unidirectional rotation by changing the tilting pad pivot point.



# Sleeve Bearing Lubrication

- Hydrodynamic Fluid Film Lubrication: Shaft rotation builds an oil wedge to float the shaft. Shaft rides on an oil film- No metal to metal contact.
- Lubricant is light turbine oil.
- Self Lubrication – oil is drawn from the sump to the shaft with an oil ring.
- Forced Lubrication – oil is delivered to the shaft from an external pump. Also known as Flood Lubrication.
- Oil Bath – bearing is submerged in oil.

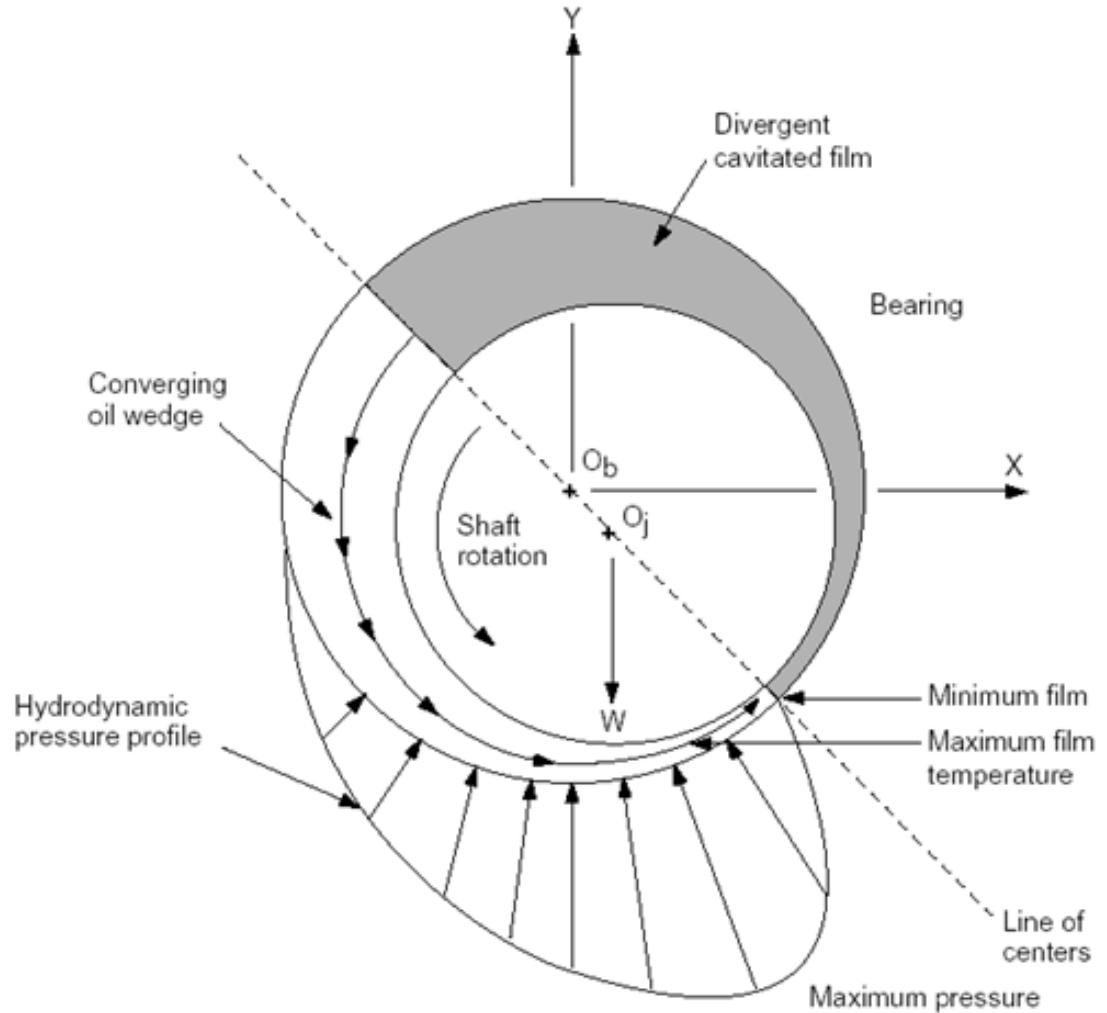

# Sleeve Bearing Lubrication – Self Lube

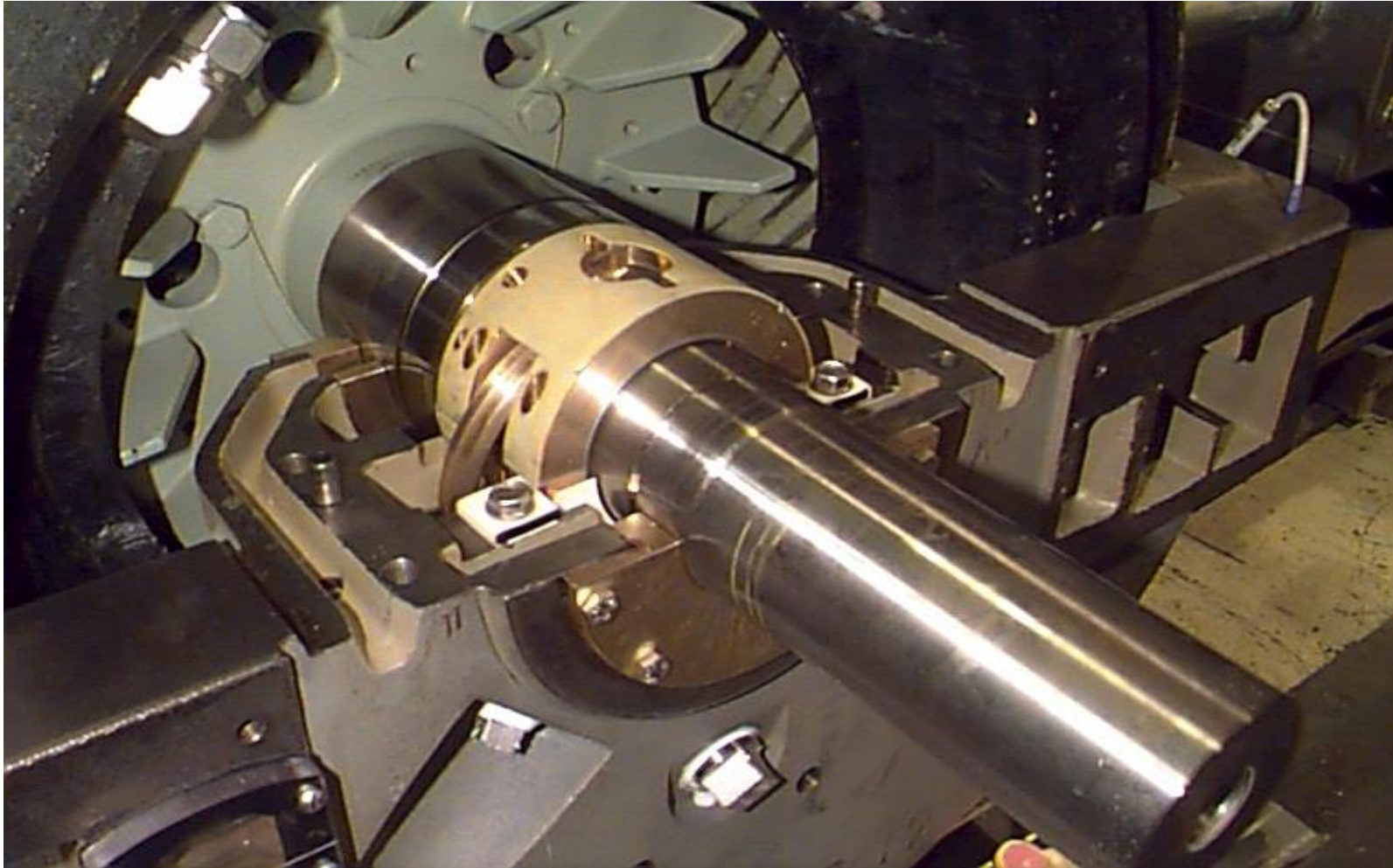

# Sleeve Bearing Lubrication – Forced Lube

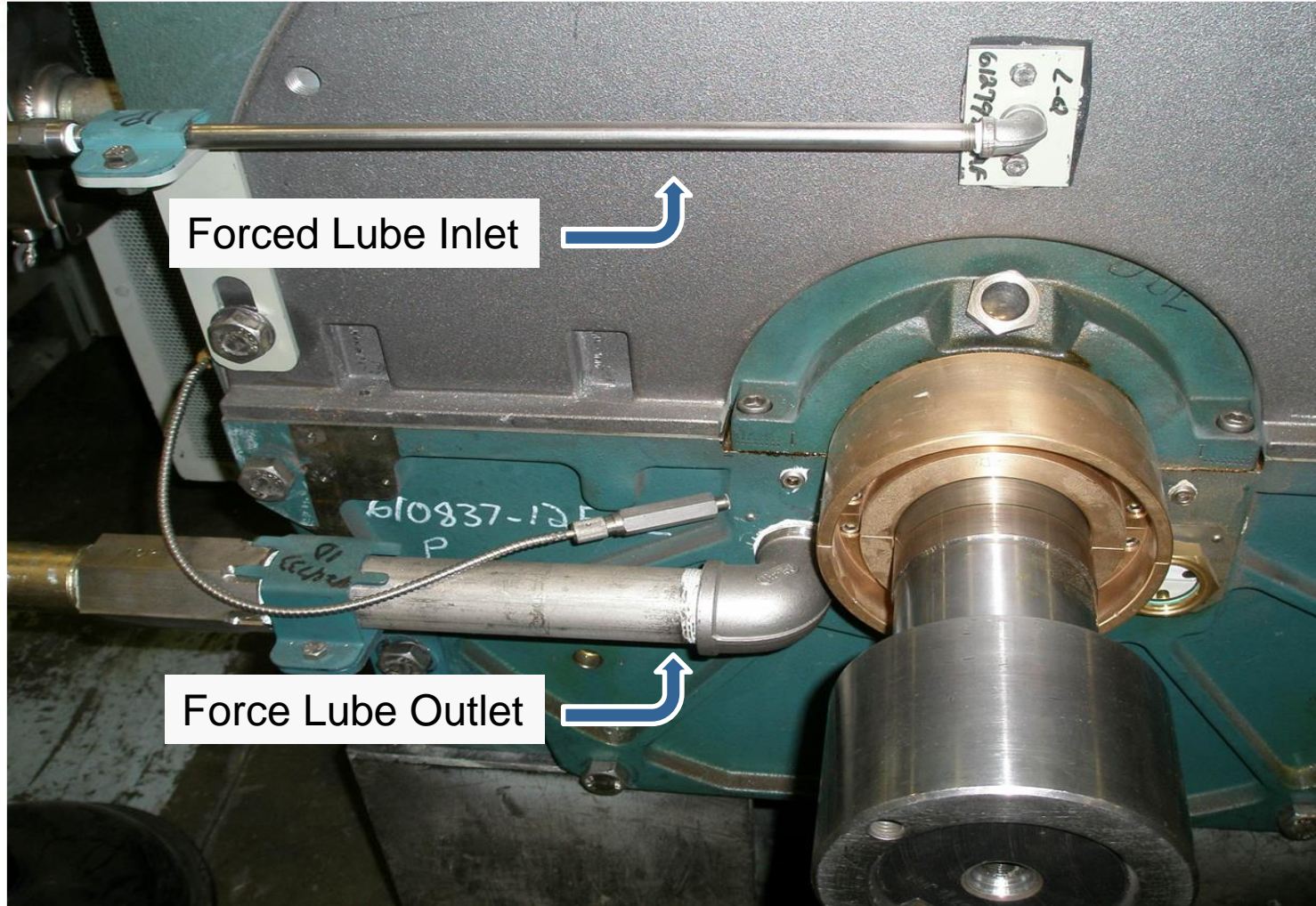

# Sleeve Bearing Lubrication - Oil Bath

- Used on vertical motors.
- Thrust pad completely in oil.
- Tilt-pad journal partially in oil.
- Cooling coils on high thrust applications.

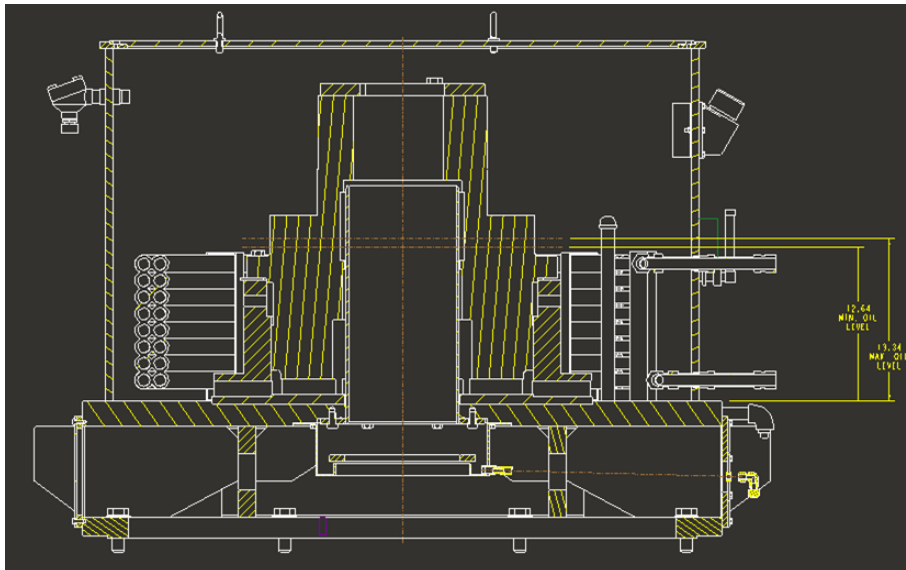
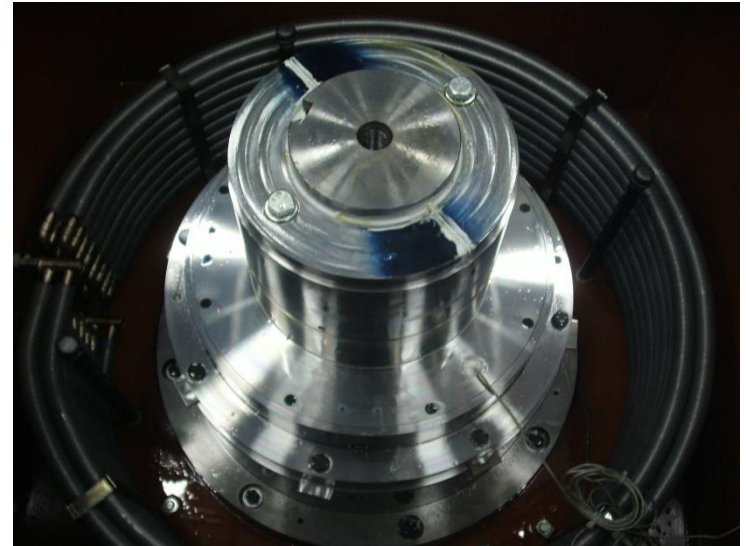

# Motor End Plates

- Motor end plates support the bearing housings.
- A secondary purpose is to prevent foreign objects from entering the motor.
- Typical construction materials are cast iron or fabricated steel.
- End Plates are also known as:
  - › End Bells
  - › End Brackets
  - › End Shields
  - › Bearing Brackets



# Motor End Plates – Antifriction Bearings

- End plates for antifriction bearings are usually one piece construction.
- Bearing housing is integral to the end plate.
- Notice the ribbed construction for added strength.

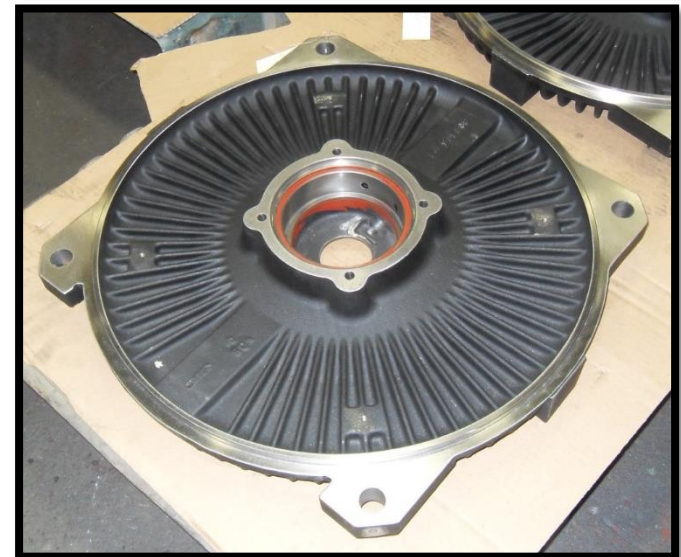

# End Plate Seals for Antifriction Bearings

- Close running fit
  - › Most basic type of seal

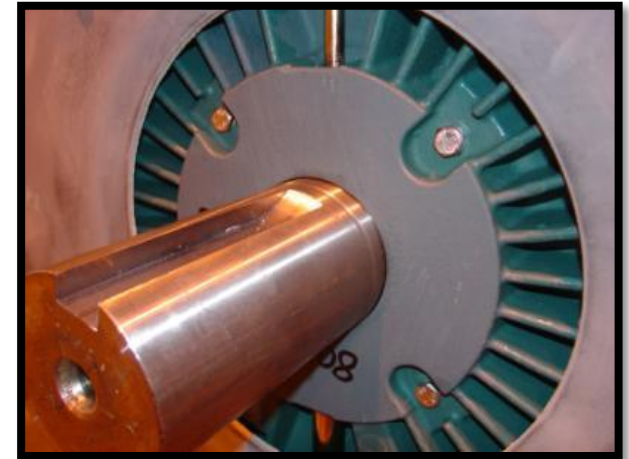
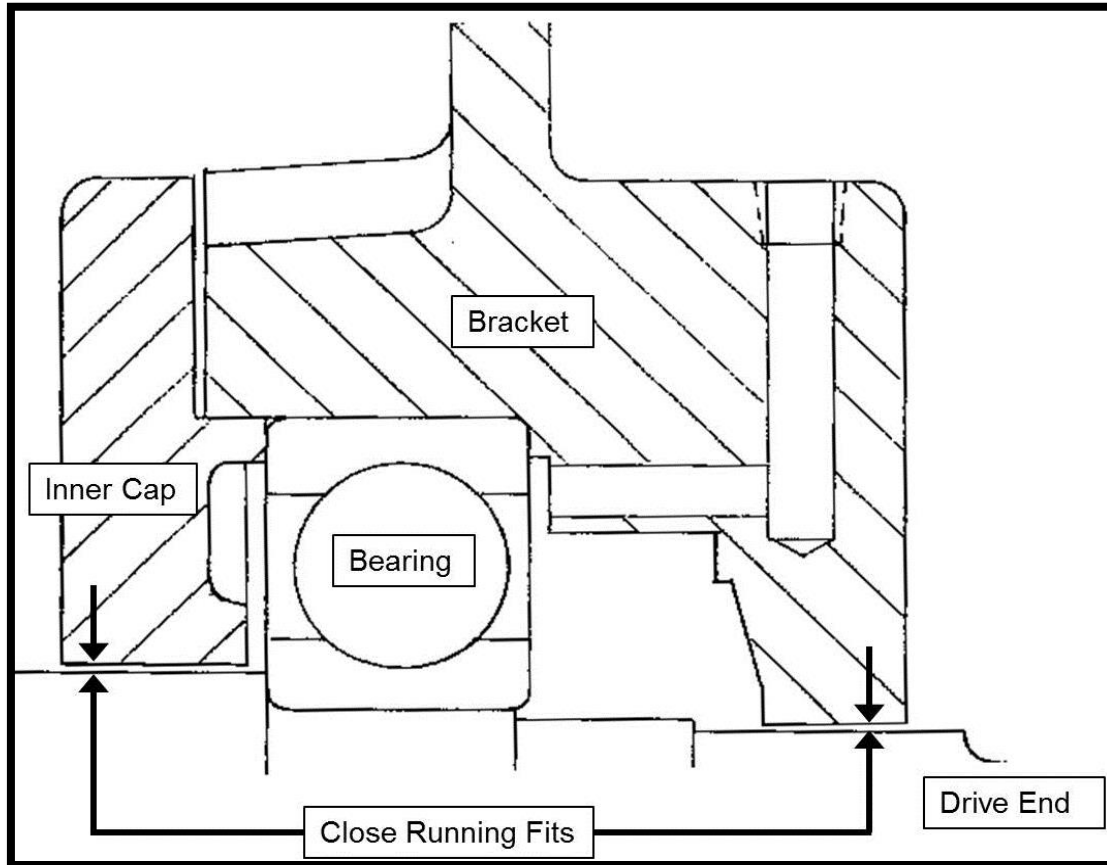



# End Plate Seals for Antifriction Bearings

- Close running fit with a slinger
- External slinger provides extra level of protection
- Slinger may be brass or rubber

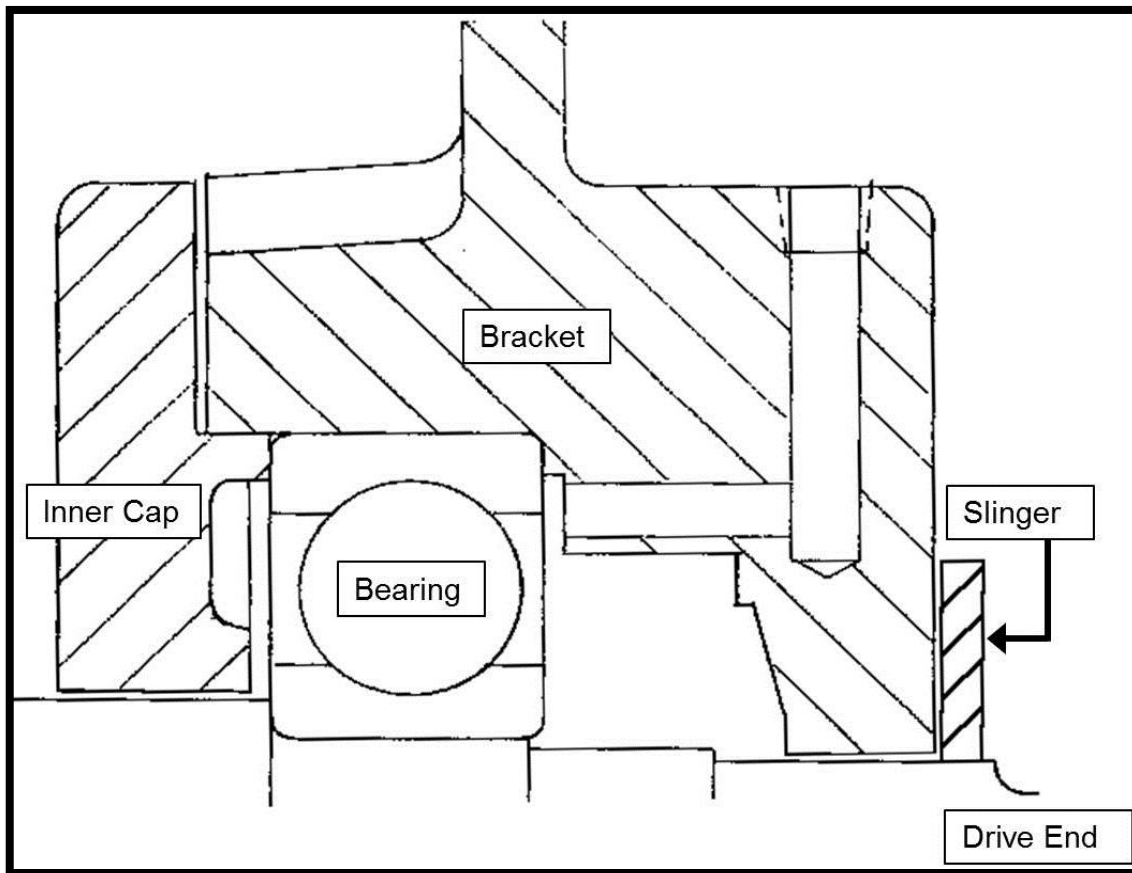

# End Plate Seals for Antifriction Bearings

- Bearing isolator
  - › Two piece design.
  - › Multiple labyrinths and O-ring protection.

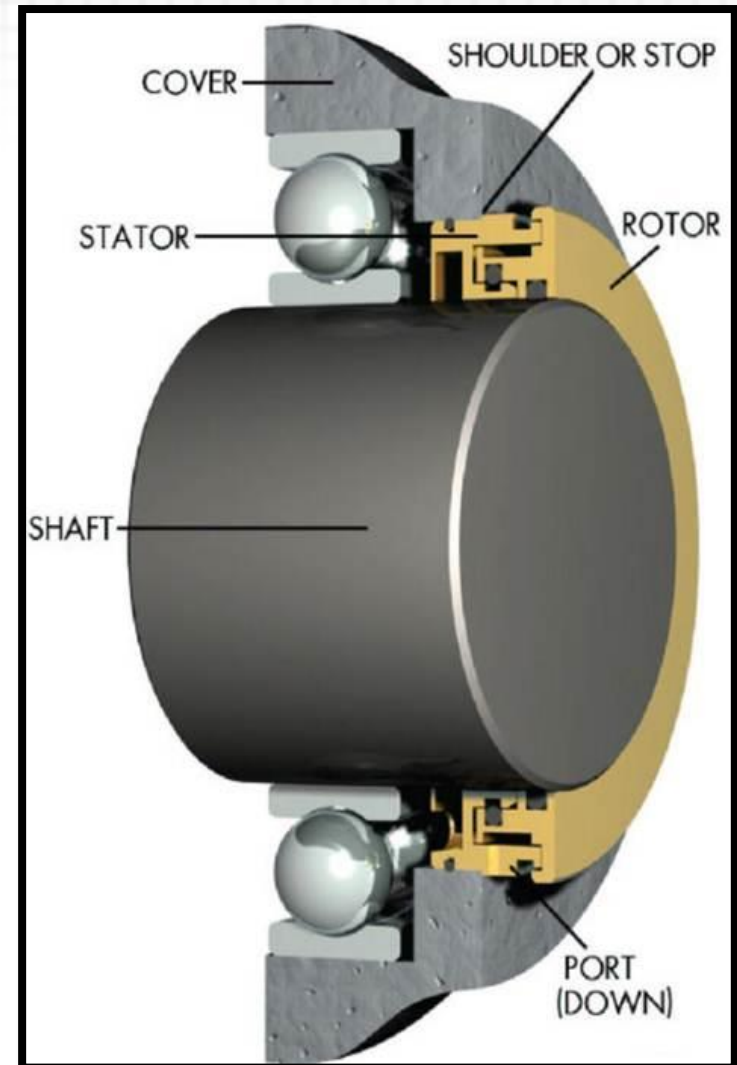

# Motor End Plates – Sleeve Bearings

- End plates for sleeve bearings usually only enclose the bottom half of the stator. This allows the bearings to be removed for inspection or repair.
- In most cases, the lower half of the bearing housing is integral to the end plate. The upper half of the bearing housing is always a separate piece.

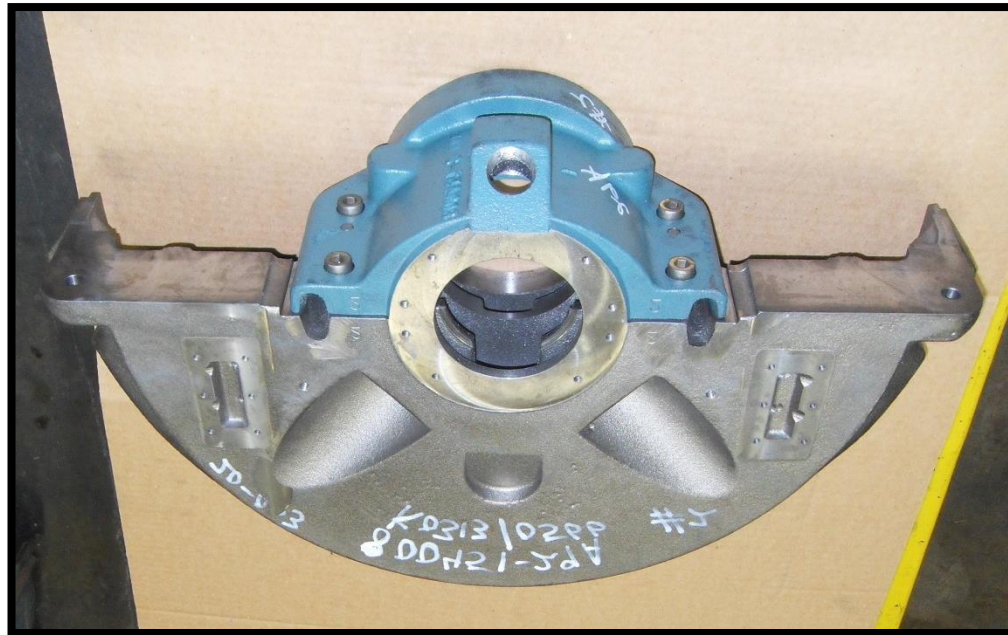

# End Plate Seals for Sleeve Bearings

- Close running fit - cast iron
- Shaft will be damaged by hitting seal areas if the bearing fails.

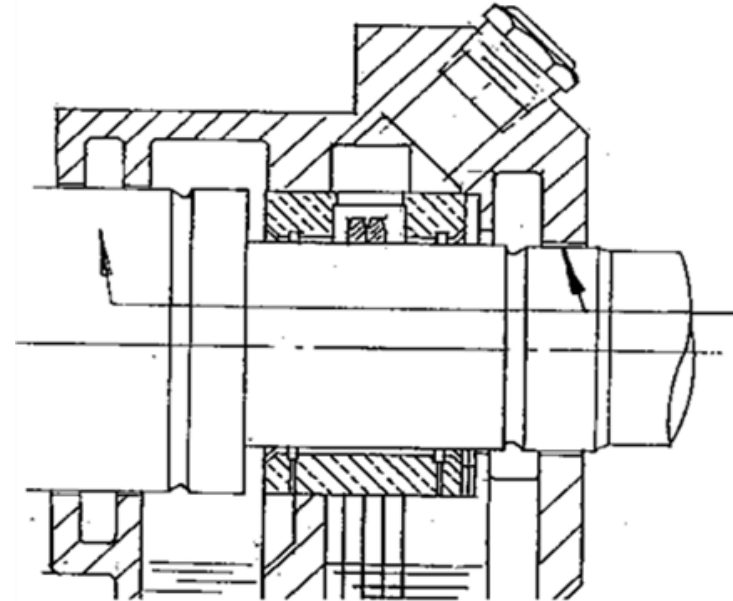
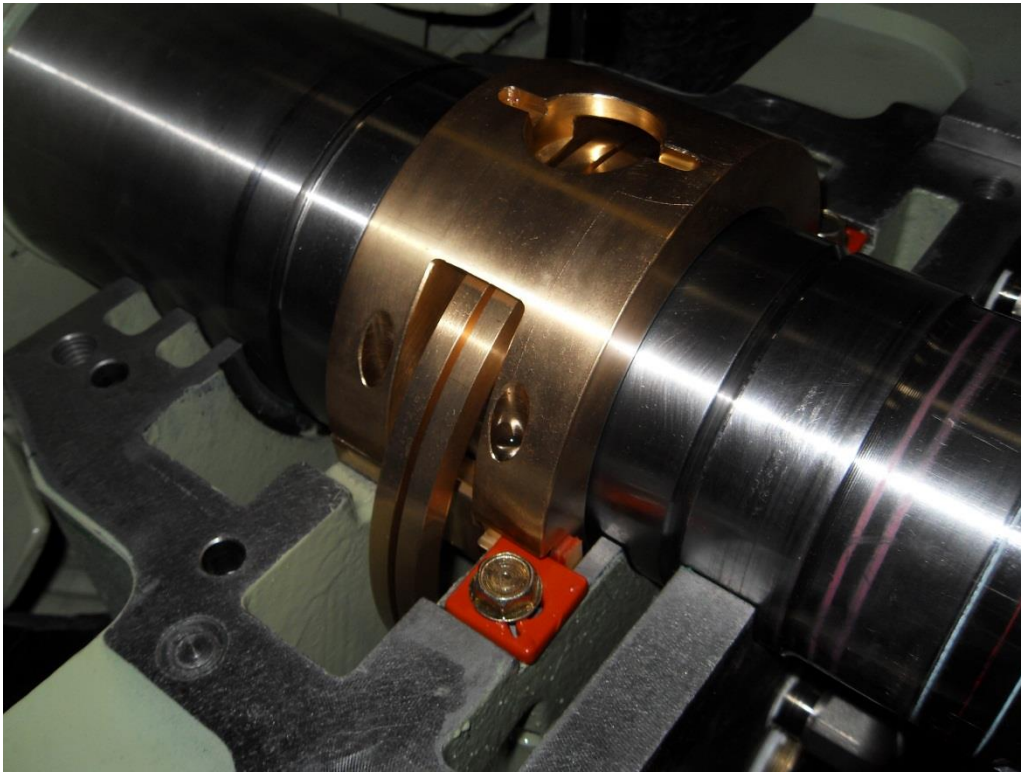

# End Plate Seals for Sleeve Bearings

- Close running fit - brass seal areas.
- Shaft damage will be minimized if bearing fails.

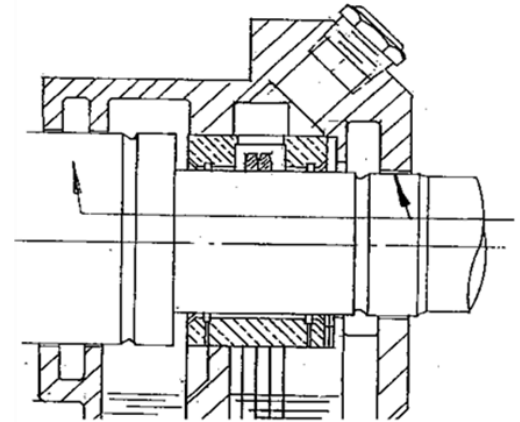
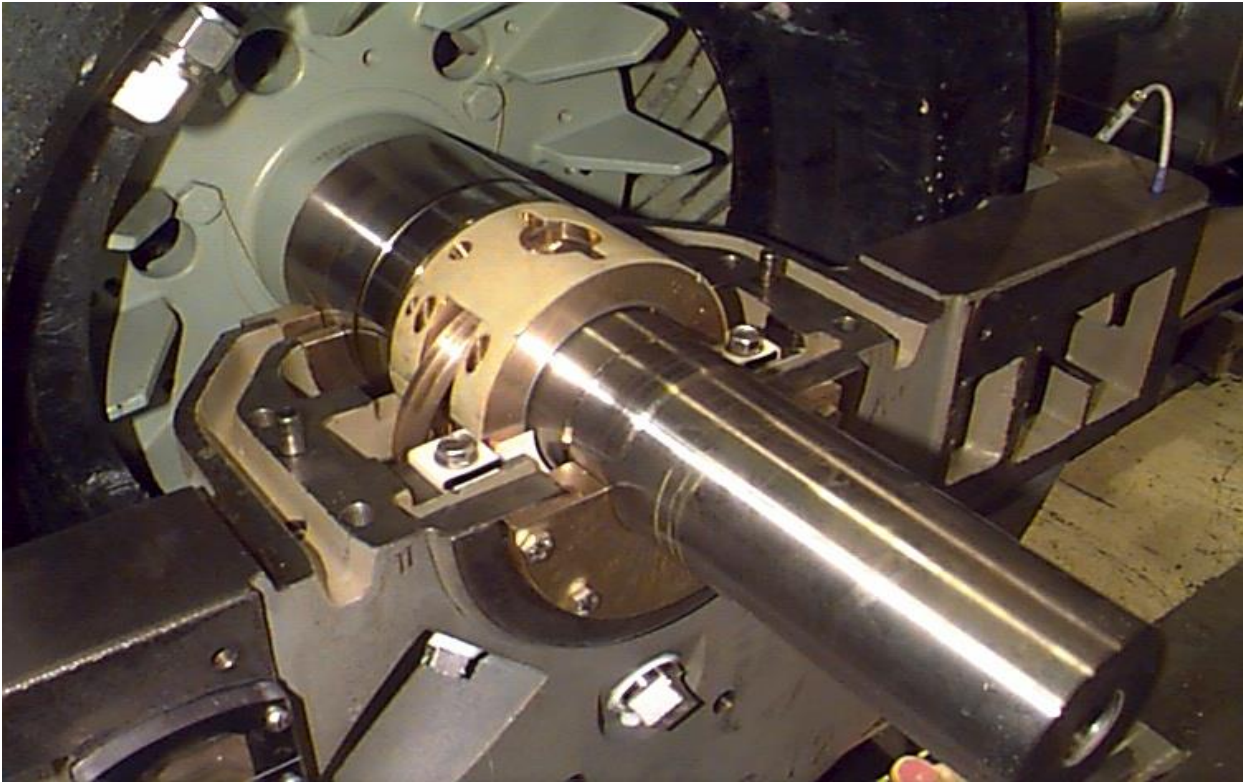

# End Plate Seals for Sleeve Bearings

- Coast-to-rest labyrinth seals.
  - › Replaces close running fits.
  - › Brass or aluminum construction
  - › Non-sparking for Division 2 locations
  - › Minimizes shaft damage if bearing fails.

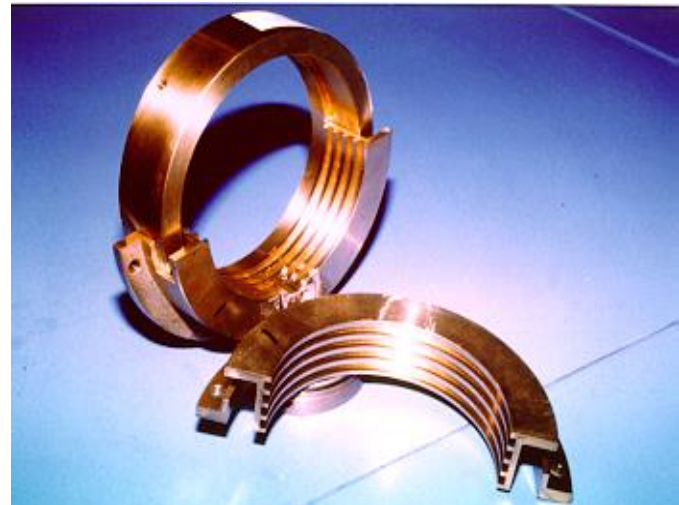
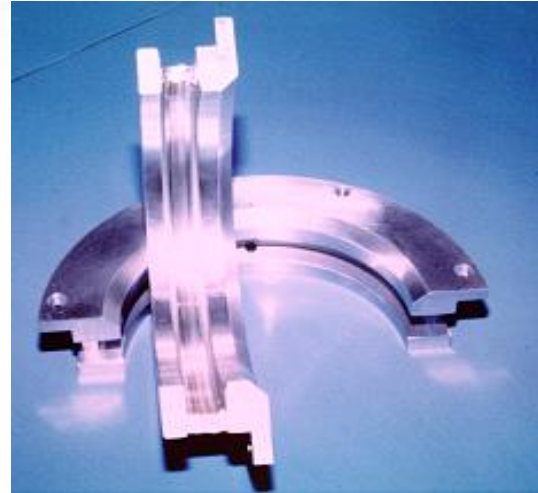

# End Plate Seals for Sleeve Bearings

- IP55 seals
- Non-sparking brass construction.
- Combines close running fit with shaft slinger.
- Premium protection against contaminants entering into bearing.

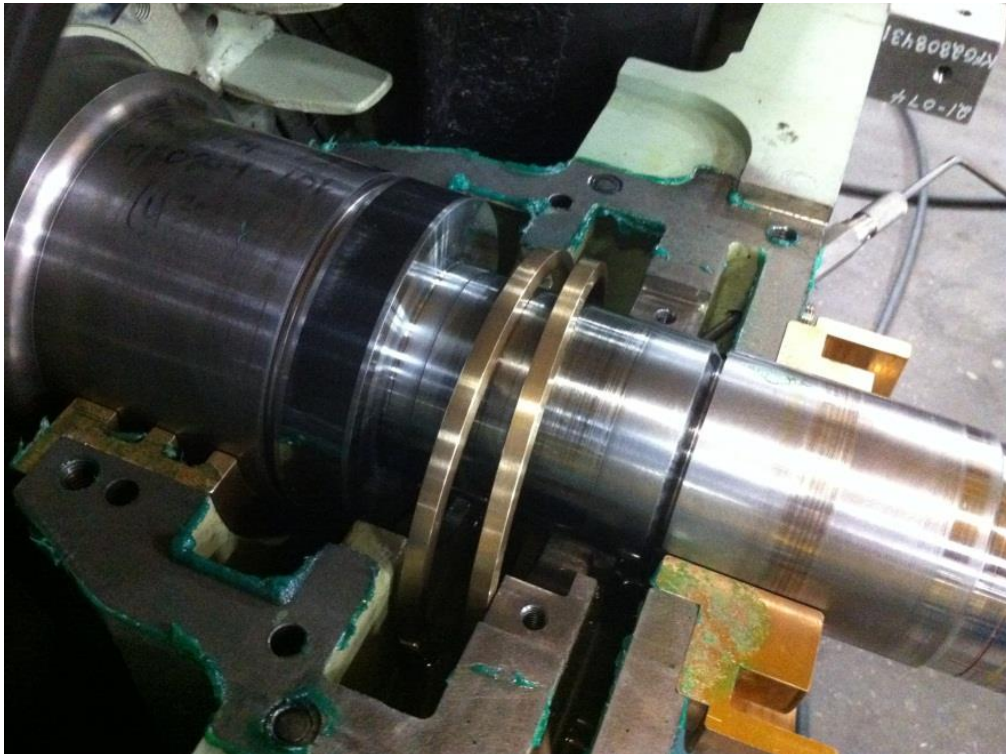

# Motor Enclosures

- The motor frame provides protection for the stator windings, conducts heat away from the stator of the motor, and provides rigidity to the complete motor assembly.
- Typical construction materials:
  - › Steel Band: Carbon and Stainless Steel
  - › Cast Iron: Grey and Ductile Iron
  - › Fabricated Steel
  - › Extruded Aluminum
  - › Laminated
- Typical Enclosure Types (more than 20)
  - › Totally Enclosed Fan Cooled (TEFC)
  - › Open Drip Proof (ODP)
  - › Totally Enclosed Non Vent (TENV)
  - › Totally Enclosed Air Over (TEAO)





# Motor Enclosures



Open  
Systems

Enclosed  
Systems

# Motor Enclosures - Enclosed

- Total Enclosed Non-Ventilated (TENV)
  - › Suitable for dirty or corrosive environments.
  - › No exchange of cooling air from the outside to the inside.
  - › Cooled by convection.
  - › Normally only available on smaller ratings.



# Motor Enclosures - Enclosed

- Total Enclosed Fan Cooled (TEFC)
  - › Most common type of enclosure
  - › Suitable for dirty or corrosive environments.
  - › No exchange of cooling air from the outside to the inside.
  - › Cooling air driven across frame by motor driven fan on NDE.
  - › Medium and Large TEFC normally have ribbed frames to increase cooling surface area.

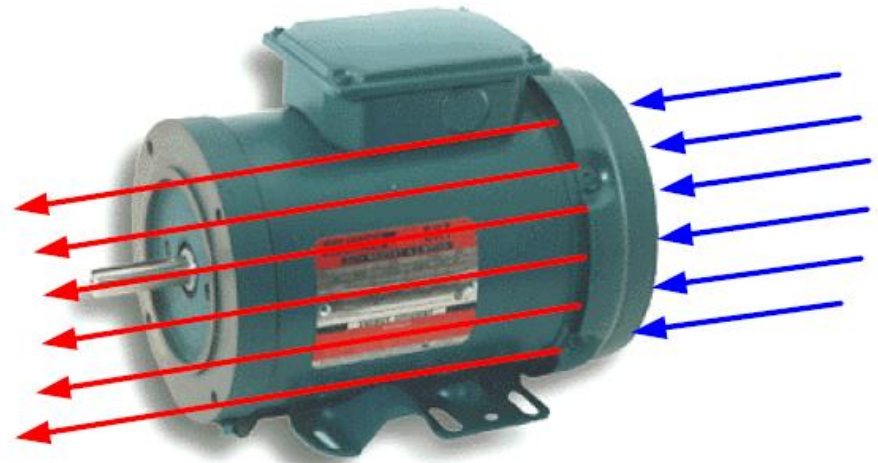

# Motor Enclosures - Open

Motors with open circuit cooling utilize atmospheric air pulled directly into the motor internals, and then exhausted back to the atmosphere, to dissipate internally generated heat.

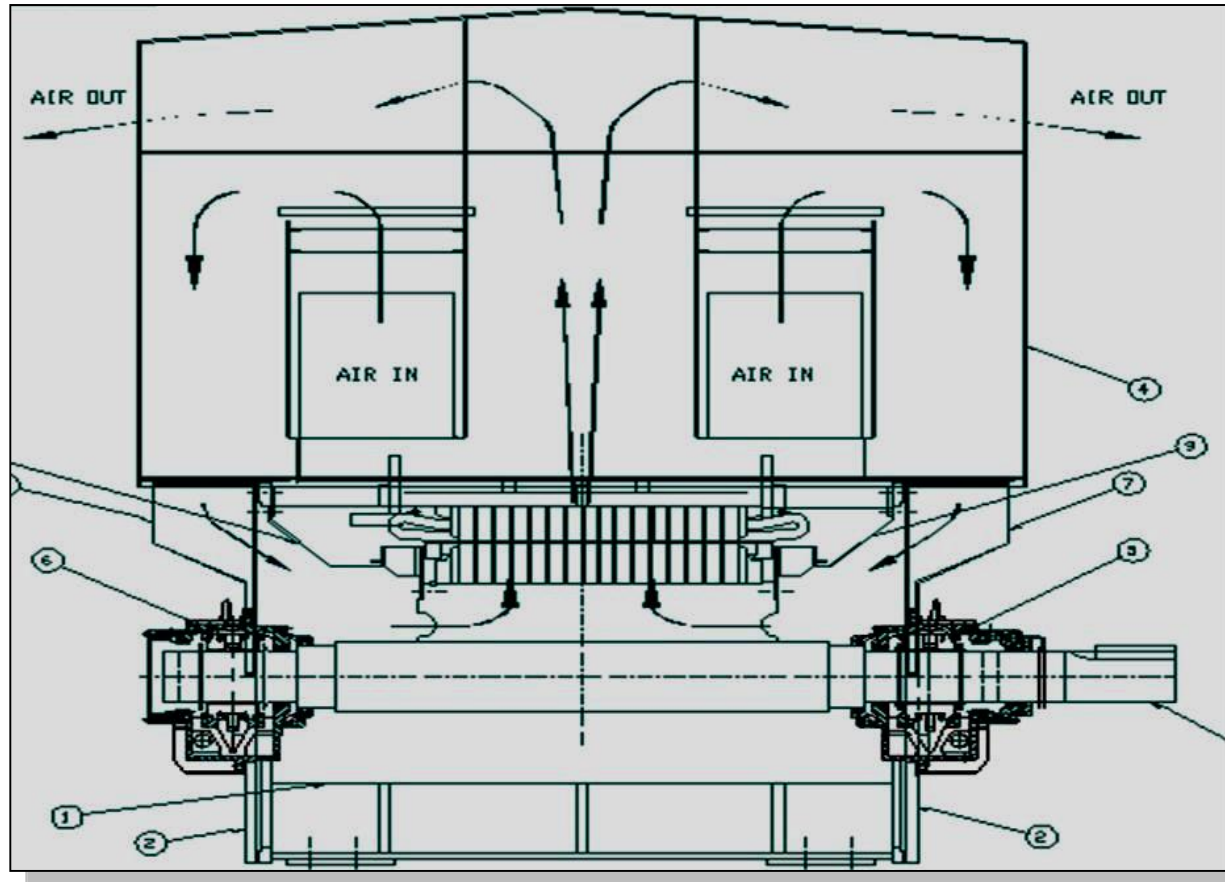

# Motor Enclosures - Open

- Open Drip Proof (ODP)
  - › Suitable for areas with reasonably clean air and non-corrosive environments.
  - › Protects from water drops falling at up to 15° from the vertical.
  - › Cooling air drawn through motor by internal shaft driven fans.

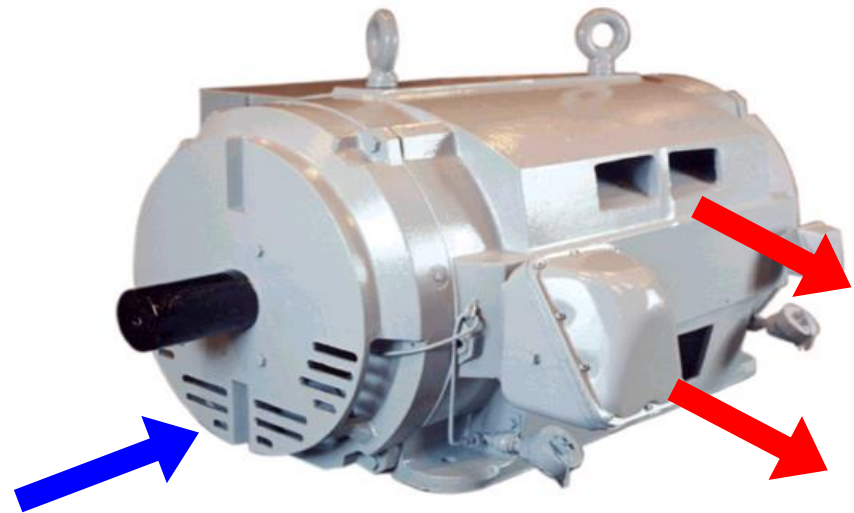

Cool air enters through both end plates

Warm air exhaust from both sides of frame

# Motor Enclosures - Open

- Weather Protected (WP-II)
  - › Suitable for areas with reasonably clean air and non-corrosive environments.
  - › Suitable for outdoor use in heavy weather.
  - › Cooling air drawn through motor by internal shaft driven fans.
  - › Once inside the motor hood, cooling air makes three 90 degree turns to allow water and foreign objects to drop out of the air stream.

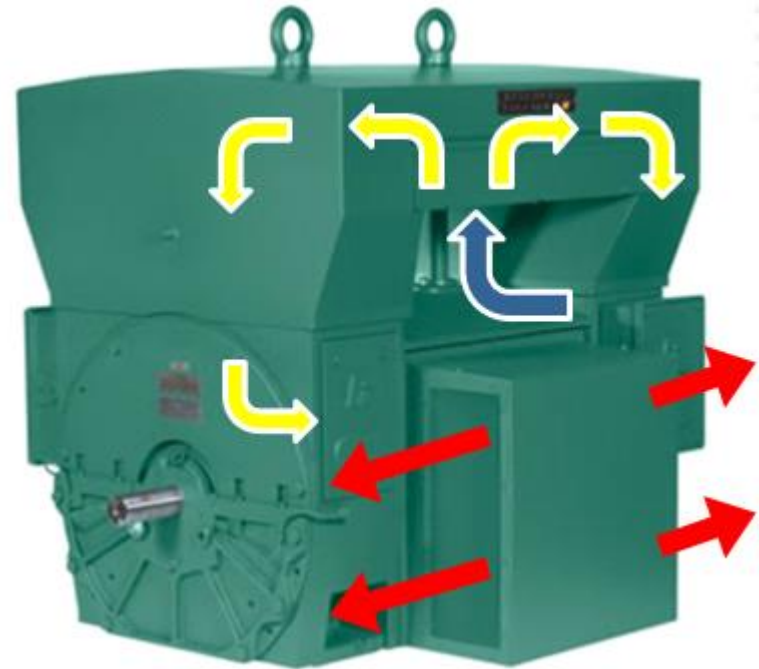

Cool Air (in) – Blue  
Internal Air Flow - Yellow  
Warm Air (out) - Red

# Motor Enclosures - Enclosed

- Enclosed with Heat Exchanger

- › The primary cooling air circulates inside the motor, while the external cooling medium (e.g. water or air) is used to transfer internally generated heat from the primary to external cooling system.

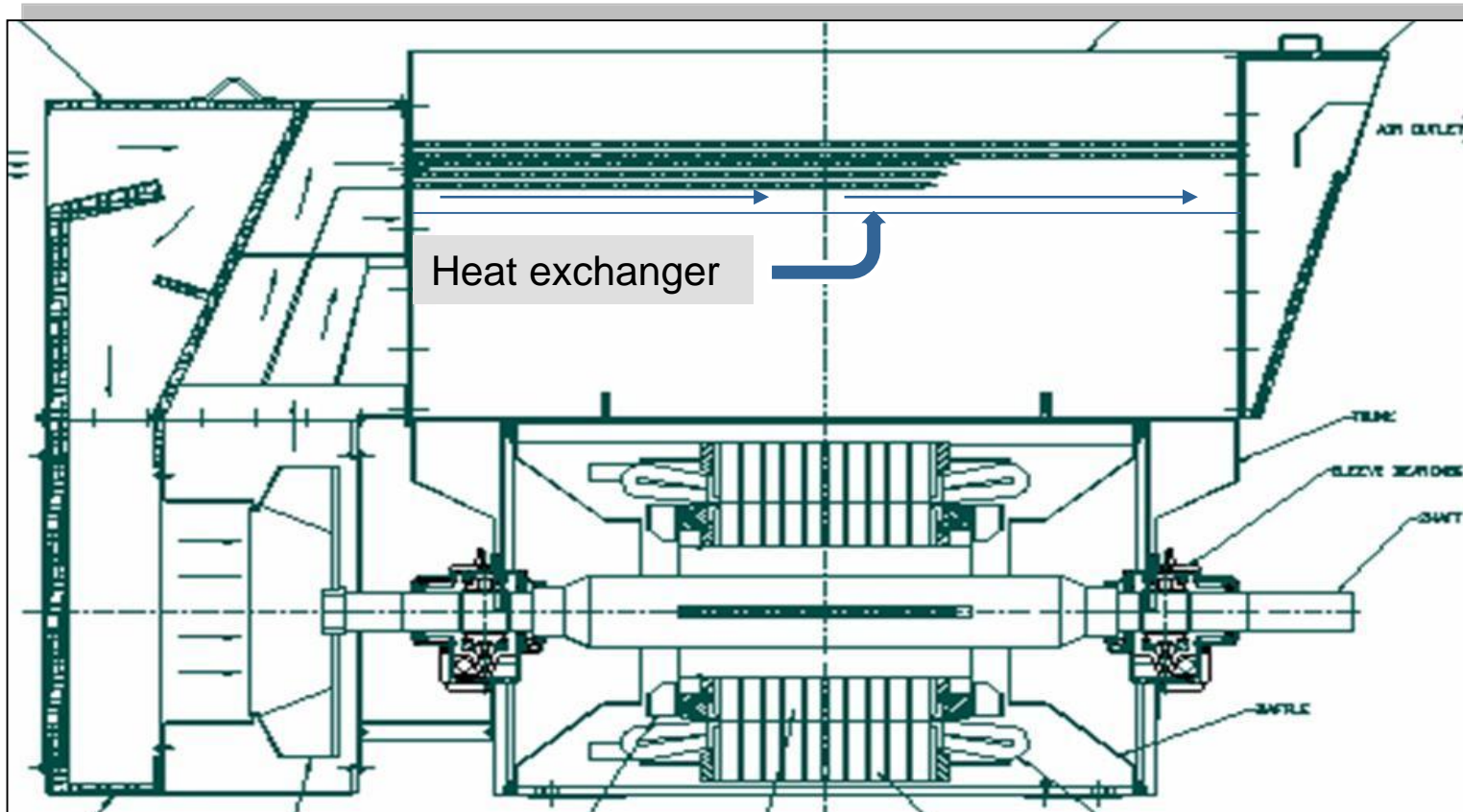

# Motor Enclosures - Enclosed

- Totally Enclosed Air-Air Cooled (TEAAC)
  - › Primarily used only on Large AC motors.
  - › Suitable for dirty or corrosive environments.
  - › No exchange of cooling air from the outside to the inside.
  - › Outside cooling air is forced through heat exchanger tubes by external shaft driven fan.
  - › Internal cooling air is circulated across heat exchanger by internal shaft driven fans.





# Motor Enclosures - Enclosed

- Totally Enclosed Water-Air Cooled (TEWAC)
  - › Primarily used only on Large AC motors.
  - › Suitable for dirty or corrosive environments.
  - › No exchange of cooling air from the outside to the inside.
  - › Cooling water is forced through heat exchanger tubes by external pump.
  - › Internal cooling air is circulated across heat exchanger by internal shaft driven fans.
  - › Internal air flow similar to WP-II.



# Motor Enclosures – Variable Speed

- Variable speed motors enclosures feature external blowers to provide continuous cooling while running at low speeds
- Other than the blower cooling, they have similar features to self cooled open or enclosed motors.
  - › TEFC-BC
  - › ODP-FV
  - › TEAAC-BC
  - › TEWAC-BC



# Motor Enclosures - Mounting

- Different applications require different types of motor mounting.
  - › Foot Mounted: most common
  - › Flange Mounted
    - C- Flange/D-Flange: direct mounting to pump or gearbox
    - P-Base: direct mounting to pump flange for vertical pump motors



Foot Mount



D-Flange



C-Flange



P-Flange

# Motor Enclosures - Mounting

Section I  
DIMENSIONS, TOLERANCES, AND MOUNTING

MG 1-2011  
Part 4, Page 13

## FLOOR MOUNTINGS



ASSEMBLY F-1



ASSEMBLY F-2



ASSEMBLY F-3

## WALL MOUNTINGS

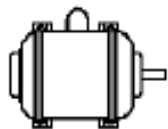

ASSEMBLY W-1

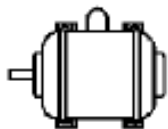

ASSEMBLY W-2

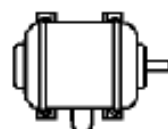

ASSEMBLY W-3

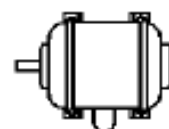

ASSEMBLY W-4



ASSEMBLY W-5



ASSEMBLY W-6



ASSEMBLY W-7



ASSEMBLY W-8

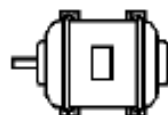

ASSEMBLY W-9



ASSEMBLY W-10



ASSEMBLY W-11



ASSEMBLY W-12

## CEILING MOUNTINGS



ASSEMBLY C-1



ASSEMBLY C-2



ASSEMBLY C-3

Figure 4-6  
MACHINE ASSEMBLY SYMBOLS

# ABB – Automation and Power World

## Houston: 2-5 Mar 2015



ABB Automation & Power World - Join us March 2-5, 2015, Houston, TX





Power and productivity  
for a better world™

