



# **Project Engineering Requirements - Pt 1**

**IEEE-CED  
Houston, Texas**

---

*By: Mark T. Leyton ([mark.leyton@bp.com](mailto:mark.leyton@bp.com))*

**February 04 2014**



# **CED Class Description**

***How to successfully implement small projects and upgrades in existing facilities. Focus on the studies required and the documentation that should be revised.***

**Primarily on Petro/Chem work.**

**Brownfield Work**

**Any Questions about  
this description???**



# Presentation Objectives

---

- **Understand some of the basic steps to start a petro/Chem project as the lead electrical engineer... and be successful.**
- **Whom you should interface with on a regular base.**
- **How to CYA successfully without upsetting your boss.**
- **How to achieve the **impossible** of on time and under budget project.**



# Where do Projects Come From?

**Have you ever wondered where projects come from? Do they appear out of thin air? No! Projects are the result of an opportunity or a need.**

## **Opportunity**

- **Increase throughput by doing a small debottlenecking project.**
- **Bring a new product to market**

## **Need**

- **React to government regulations (remember MTBE?)**
- **Replacing old SWGR or MCC's**
- **Arc flash issues**
- **DCS or SIS obsolete and needing to be replaced**
- **Update/upgrade or shutdown the facility**
- **System growth (Electrical utilities)**
- **Decommissioning & demolishing**



# Two Types of Projects

In the classical engineering vernacular there are two types of projects, Brownfield and greenfield.

**Brownfield**:- The project will be in, around and tie into an existing facility.

**Greenfield**:- A site where everything will be new and installed from scratch.

Are FPSO's in the future?

We are going to concentrate on **Brownfield** work. However there will be references to **Greenfield** work because of common work efforts.

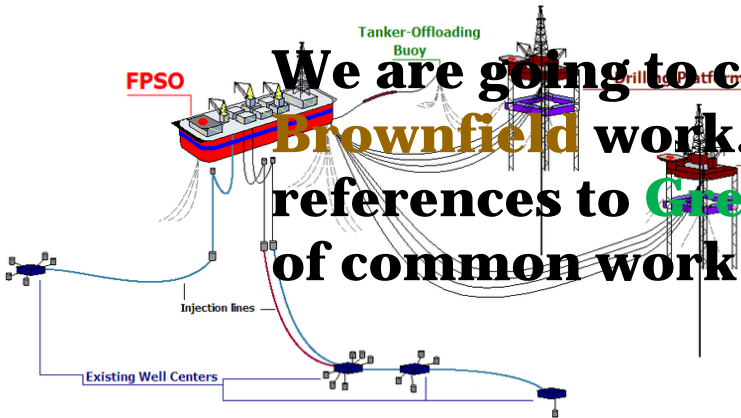

or both

ing sed



# Brown -V's- Greenfield Work

Brownfield	Greenfield
Existing Power supply adequate?	New power from?
Get old studies and update or recreate by gathering data	All new studies
Challenge to squeeze it in or no space left	All new equipment, easy layout
Duct bank and tray system full	Designed from scratch
Existing equipment ratings exceeded	Designed from scratch
Lost drawings	Nice new drawings
Mylar or Sepia	CAD
What's Division? Like Addition?	Division or Zone?
MCC's obsolete – should be in a museum	Designed from scratch
Can't even see the MCC's lights	Nice new LED lighting
1988 era 13.8kV Substation fully louvered	13.8 kV arc resistant Substation with HVAC
Rack in by hand	Remote racking
Broke ATS locked in position	New remote controlled ATS



# Brown -V- Greenfield Cont.

Brownfield	Greenfield
Can't isolate equipment	Isolation built in
Can't take a shut down to fix it	Flip to other side, power down and install
Environmental issues grandfathered in	Environmental issues to resolve
Home Dept switches	Proper switches
Oil everywhere	Nice and clean site
Drawings never updated since "Issued for Construction"	Will deliver "as constructed" drawings
Electromechanical relays	Smart multifunction relays
Only contractors running the site	New employees running the place
Hand written safe operating procedures	Computer tracked procedures
Asbestos insulation	Environmentally friendly insulation
Can't find it in the field. It's gone!	Installed per the drawings
Spec's – are they like safety glasses?	Use Client's Specifications
<b>Engineering is challenging</b>	<b>Engineering is easier</b>



# The Project Process

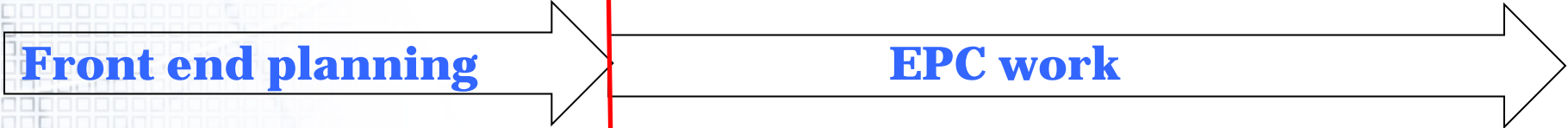

<b>Feasibility (FEP-1)</b>	<b>Concept (FEP-2)</b>	<b>Detailed Scope (FEP-3)</b>	<b>Design</b>	<b>Construction</b>	<b>Commissioning</b>	<b>Operation</b>
Identify business opportunity & Confirm business fit	Generate & assess technical & commercial scenarios <b>Then</b> Evaluate & select optimum plan	Prepare basis of project/spec's	Engineer, procure & construct equipment	Assign, procure & get building	Activities start and continue through the item	Using SOP's the customer can operate the facility in a safe and productive manner
			<b>Decommission</b> Some companies will add decommissioning into the Project Process to make it cradle to grave.			





# Detailed Scope (FEP-3) Output

At the conclusion of Detailed Scope (FEP-3), the output is the **Basic Engineering Package** or **Front End Engineering Design (FEED) Package** *generally* consists of the following items.

- ✓ **Design Basis & Client's Standards**
- ✓ **Process Description**
- ✓ **Production and Consumption Numbers**
- ✓ **Optimized Heat & Mass Balance**
- ✓ **Process Flow Diagram (PFD's)**
- ✓ **Piping & Instrumentation Diagram (P&ID's)**
- ✓ **Equipment Process Data Sheets (PDS)**
- ✓ **Instrument Process Data Sheets (IPDS)**
- ✓ **Equipment List and Line List**
- ✓ **Utility Flow Distribution**
- ✓ **Drawings Plot Layout / Conceptual Layout**
- ✓ **Etc.,**

**This is the technical list. There is a comparable commercial list.**

This is what goes out for EPC's to bid on. **I.E. Bid documents.**



# IFP of FEED-EPC



Talara Refinery Modernization Project

INVITATION FOR PROPOSAL  
OF  
FEED-EPC CONTRACTOR

INTERNATIONAL BIDDING PROCESS  
N° PCI-002-2008-OPF/PETROPERU  
TO CONTRACT THE FEED-EPC EXECUTION  
SERVICE FOR THE TALARA REFINERY  
MODERNIZATION PROJECT

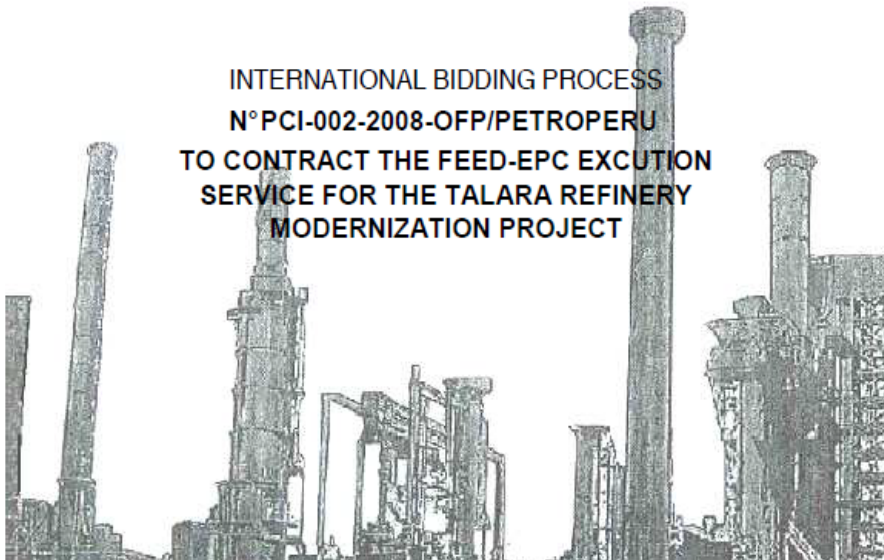

**This is a “typical” IFP package consisting of several binders worth of commercial and technical documents accompanied by several key drawings.**

[Addendum1.pdf](#)

**Engineers seldom get involved in commercial documentation.**



# RS Means – One Way

## Cost Estimation - CSI Masterformat Numbering System

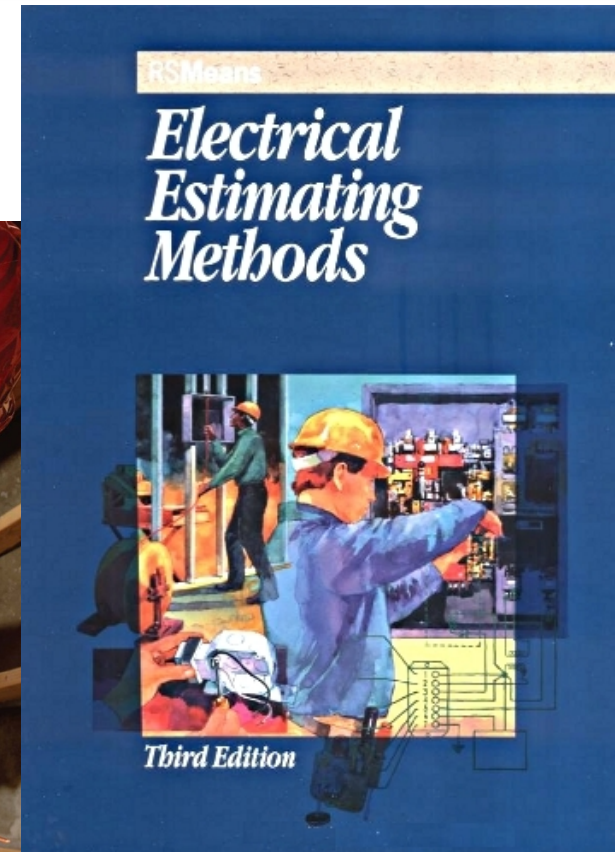
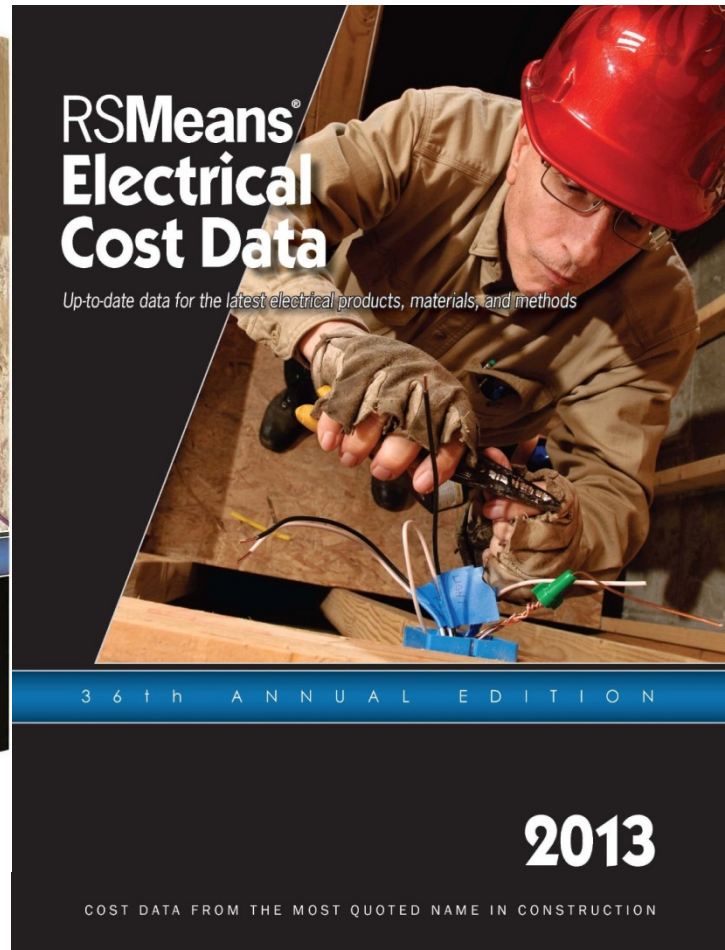
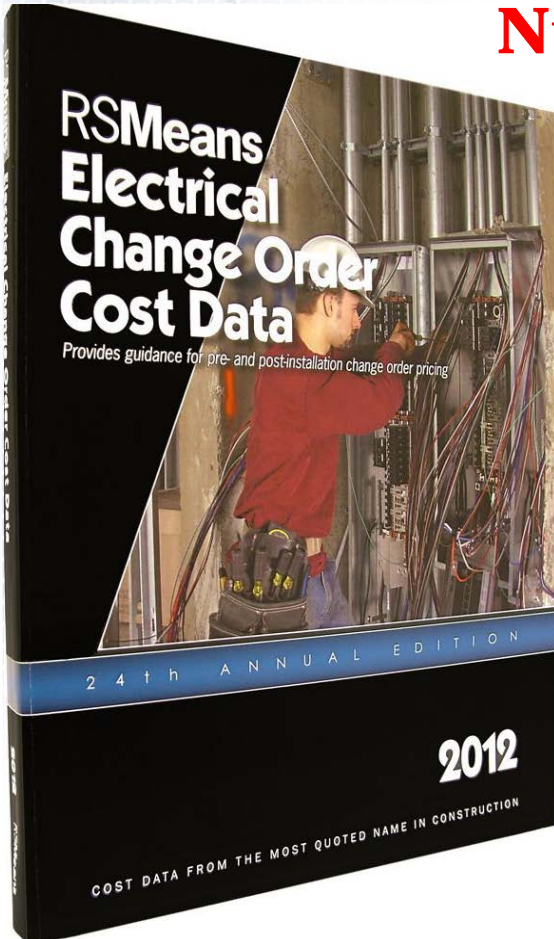



# Electrical MH Cost Estimate

## **EE** – **How many...**

- ✓ **Equipment Specs**
- ✓ **Equipment bid packages**
- ✓ **Studies**
- ✓ **Assumptions In...**
- ✓ **Exclusions Out...**

## **EE** – **Does...**

- ✓ **Get estimates**
- ✓ **Does the final EE estimate**
- ✓ **Assign cost to MTO lists**
- ✓ **No fudge factors included**

## **Designer** – **How many...**

- ✓ **Plans (demo & new)**
- ✓ **Sections (demo & new)**
- ✓ **Details (new or old)**
- ✓ **Wiring diagrams**
- ✓ **Interconnection diagrams**

## **Designer** – **Does...**

- ✓ **Fast layout dwg for MTO**
- ✓ **MTO lists**

**Or an estimator does it all.**



# Electrical Spec's

Electrical Spec's		
Basic Design	DC Charger (DC system)	HV Ckt Switchers
Batteries	Design Criteria	HV Disc Switches
Building – Electrical Services	Diesel Engine Set	Inspection & Testing
Building Prefab	Electric Heater	Interface
Cables	Electrical Construction	Load Int Switches – MV
Cable Installation	Electrical for Skid Mounted Equipment	Motors – LV
Capacitors	Engines – Diesel	Motors – MV
Cathodic Protection	Generators	Navigational Aides
CCTV	Grounding Equipment – High Res	Protective Devices
Compressors – Centrifugal	Grounding Equipment – Neutral	Public Address & Alarm Systems
Compressors – Reciprocating	Heat Tracing – Electrical	Rectifiers
Conduit	HV Ckt Bkrs	Switchgear Assemblies

**Anyone using the National Electrical Installation Standards??**



# More Electrical Spec's

## More Electrical Spec's

Switchrack – Outdoors	Turbines – Steam	VFD's
Transfer Switch	Unit Substations	Wood Poles & Crossarms
Transformers	UPS Systems	
Turbines – Gas	Vendor Data	

**Need to get bid packages out fast for inclusion in the estimate. This is why you need a designer assisting the EE.**

**Out of all engineering disciplines electrical has the most (that is numerically) spec's to know and understand. The problem is, we don't use them enough to become proficient in all the nuances of the spec's we use and the underlying IEEE, NEMA, ANSI, etc., documents.**

**How many EE's do you know are skilled in both North American standards/spec's and IEC standards/specs?**



# EE Studies

## Electrical Studies List

Load Flow	UPS Sizing	Heat Release Studies
Short Circuit	Duct Bank heating	Stability Analysis
Relay Coordination	Cable tray Fill	Switching Transient
Motor Starting	Cable tray Heating	Reliability Analysis
Arc Flash	BIL Calculation	Insulation Coordination Study
Harmonic Analysis	Cap Bank Sizing	
Voltage Drop	Cable Pulling calculation	
Battery & Charger Sizing	Area Classification Work	
Lighting Design	Cable & Conduit Sizing	
Lightning protection Design	Emergency Gen Sizing	
Ground Grid Design	Cathodic Protection	

**How many studies are you going to do? A preliminary and a final? How much money for the final?**



# Relays, GOOSEing & ENMCS

- 1. Smart relays take far more time to program than old electromechanical relays.**
- 2. How are you programming your smart relays? Are you using traditional methods of communication or you going to GOOSE up the system?**
- 3. Is there an existing ENMCS or are you adding one in? How much time are you allowing for this?**

**Is the regular EE qualified to estimate this type of work? What are you going to bid on and why? How much time are you going to allocate for each job?**





# The EE Cost Estimate

CLIENT:						ESTIMATE TYPE
LOCATION:						Lump Sum
PROJECT DESCRIPTION:						Reimbursable
						Cost Plus
PROJECT START DATE:						Fixed Rate
	MGMT/	ENGR.	DESIGN/	GRAND	COMPUTER HOURS	
	SUPV	SUPPORT	ENGR	DRAFT	TOTAL	CADD 2D
TOTAL WORKHOURS	0	0	0	0	0	0
						CADD 3D
						PERSONAL COMPUTER (PC)
	0	0	0	0	0	0
REFERENCE DOCUMENTS						WORK EXCLUDED
1. Request to perform Short-Circuit & Coordination Study.						1.
2.						2.
3.						3.
4.						4.
5.						5.
6.						6.
7.						7.
8.						8.
ASSUMPTIONS						WORK INCLUDED
CONFIDENCE LEVEL	80%					1.
1. NUMBER OF TRIPS	0					2.
2.						3.
3.						4.
4.						5.
5.						6.
6.						7.
7.						8.
8.						
9.						
10.						
11.						
12.						
13.						
14.						
15.						
PREPARER						DIVISION MANAGER
DATE						DATE

**Front page of an electrical MH estimate. Includes EE and designer hours. No contingency added. Leave that for others to do.**

[EE Est Blank.xls](#)

[Electrical Cost 2013-4 IEEE CED.pdf](#)



# Cost Estimate Assumptions

- 1. Electrical studies shall use MY LLC default software - Aspin.**
- 2. Existing Load Flow, Sht Ckt, Relay Coordination, Arc Flash studies not reviewed as data not provided. Assuming project has zero impact on the studies.**
- 3. Basler relays for electrical equipment protection only.**
- 4. Responsibility for area classification extends to project battery limits. Impact by adjacent units to project area is outside project scope.**
- 5. 10,000HP shall be DOL. Soft start method not needed.**
- 6. There is spare spaces in existing 480V MCC's for all new 480V loads.**
- 7. There is spare space in existing panels for all new 120 & 208V loads.**
- 8. The existing cable tray system has spare space for all new cables.**
- 9. Spare underground conduits are clean, usable, capped off and have pulling ropes/tapes in them.**
- 10. The existing lighting system shall be expanded to include the new areas. New lighting circuits are not required for this project.**
- 11. New roadways shall not require lighting as close to existing facilities.**
- 12. Existing grounding system is adequate and only requires expansion into the project area.**
- 13. All existing drawings are up-to-date, accurate, to scale, in AutoCAD model space format, and available at project kick-off meeting.**
- 14. All existing electrical studies –in Aspin format- calculations, reports are up-to-date, accurate and available at project kick-off meeting.**
- 15. Turn-key EPC project so no client drawing, calc, study, etc., reviews.**



# Cost Estimate Exclusions

1. **Updating existing Mylar drawings.**
2. **Converting Mylar drawings to usable AutoCAD drawings.**
3. **Inspection of any and all existing electrical equipment.**
4. **Interface work with the local Utility. Work through the client.**
5. **Validating existing drawings.**
6. **Locating known and unknown existing underground items.**
7. **Creating Safe Operating Procedures (SOP's).**
8. **Training on the new equipment.**
9. **Meetings on Monday and Friday.**

## **Digitizer, puck and a mouse?**

The digitizer (also known as a graphic tablet) and the puck are the data input devices most commonly used in CADD systems. **[In the 1980's]** These devices allow you to enter point locations on the screen and to make selections from the menus. As the puck is moved over the surface of the digitizer, it moves the indicator(cursor) on the screen relatively. To enter a point, you need to position the cursor at the appropriate position on the screen and then press the "Enter" button on the puck.



# Rule of Thumb

**The generally accepted Petro/Chem **rule of thumb** says:-**

**Engineering & design cost is  $\approx 10\%$  of total installed cost.**

**EE cost is  $\approx 10\%$  of Engineering cost.**

**Therefore EE cost is  $\approx 1\%$  of total installed cost.**

**If you calculate engineering cost it should be about 10% or something is wrong. If the client purchases major equipment then this rule of thumb will be off.**

***Easy to see why Electrical work is small potatoes in the big scheme of things.***



# You Win!

**Usually at the end of the bidding process, based on the FEP-3 output documents, an E&C is selected and the process of **Design, Construction, Commissioning** commences with a kick-off meeting.**

**If the E&C bids are out of line with expectation, the project could be recycled, canceled or new bidders sought after.**



# Are Things Equal?

**There are two sides to the contract, 1) the End User and 2) the EPC Contractor.**

**The expectations of the End User are not necessarily captured or truly expressed in the contractual documents. The End User expects high quality at a cost effective price to stay competitive.**

**The understanding of the EPC Contractor is that the issued documents contain everything necessary to satisfy the End User. EPC Contractor needs to bid minimum to stay competitive.**

**Equality depends where you stand, how you view things, and your interpretation of the signed documents.**

**Remember... the EPC EE does not have the ability to read the mind or the intent of the End User EE. It has to be in the contractual documents or it does not exist!**



# The Key Document

The **KEY** client's document EE's look for is called something like ***Basic Electrical Design Criteria***. It should contain the following basic information...

- ✓ **Codes**
- ✓ **Standards**
- ✓ **Reference specifications**
- ✓ **Area Classification**
- ✓ **Power System**
- ✓ **Lighting System**
- ✓ **Grounding System** [ELCGL01.pdf](#)
- ✓ **Cathodic Protection System**
- ✓ **Communications**
- ✓ **Wiring Methods** [Electrical Design Criteria.pdf](#)
- ✓ **Cable Tray Systems**
- ✓ **Conduit Systems**
- ✓ **Materials**
- ✓ **Lightning** [ES-7001 Design Criteria Spec.pdf](#)
- ✓ **Protection Design, etc.,**



# EPC Basic Documents

**Six important documents** to look for are as follows...

- ✓ **The IFP Package**
- ✓ **The EPC bid documents**
- ✓ **Project Schedule**
- ✓ **My Budget (Cost and/or Man-Hours)**
- ✓ **Project Deliverables List (if there isn't one make one)**
- ✓ **Project Distribution & Approval Matrix**

**These EPC documents should match/dovetail into the IFP package on your back-bar.**





# The Basic Documents... Cont.

**You need to know...** If this project in the USA and requires a PE seal to be affixed to all calcs, studies, drawings, reports, Etc.,? Who will do the sealing?

**Is there a difference** to the engineering documents and drawings if a seal is required or not?

**Is there a difference** to the cost if a seal is required or not?

What about NFPA 70-2014 490.48  
Substations ? Who is your qualified PE? If  
MV & LV should I get Powell or Volta to do  
it all? If HV, then Dominik can do it.



Doe Engineering  
F-98765

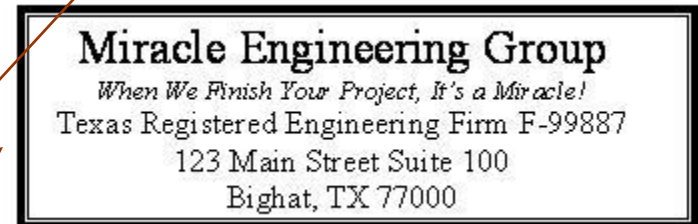

[http://engineers.texas.gov/firmseal\\_faq.htm#examples](http://engineers.texas.gov/firmseal_faq.htm#examples)



# What are the Tools of the Trade?

**As an Electrical Engineer what are the generally accepted tools of the trade? Or to look at it another way, what should you know how to use so that the project has a ghost of a chance of being successful?**

- **Get along with the client**
- **Good rapport with the project engineer**
- **Work with other disciplines**
- **Know how to ask the right questions**
- **Run a team efficiently**
- **Do reports on time**
- **Generate a load list**
- **Do studies**
- **Review drawings**
- **Deliver on time**

**Soft Skills**

**Hard Skills**



# Soft Skills

**An important soft skill is Communications. If you can't properly communicate you have failed.**

**Communications means **getting out of the chair** and visiting your opposite number in other groups. Just as you are visiting, so the lead designer is visiting his counterparts to be on top of all the changes that are coming in thick and fast.**

**Communications can also mean sending an email. **Emails document stuff** that can be used to CYA later on. One key usage of emails is to document conversations. Getting down who said what and when. Not necessarily to CYA, but to clearly document key points or when a key change was made.**

**Is your English the same as my English? Is your switchboard the same as my swgr or are you thinking panelboard?**

**See:- <http://www.bbc.com/capital/story/20140117-email-backlash-at-the-office>**



# The Start

**The start usually happens when the EPC EE is assigned to the project. Hopefully this happens at contract signing. Usually it does not as electrical is considered a supporting not a major discipline.**

**The number of people assigned to the project is usually a function of the hours the project is projected to take.**

**If it is a small project there would be something like one EE and one EE Designer. Larger projects would mean more personnel.**

**In other areas this might not hold true. For example, commercial work is very slim due to thin profit margins.**



# The Basic Project Structure

In the Petro/Chem pecking order where is the EE? Or become a HV EE. Also read Lucky's IEEE *The Bean Counters* story.

Often it is not clear who you talk to. Sometimes the PM wants to talk to you and other times it is the PE. Best to talk to both and try and remember what you said to whom.

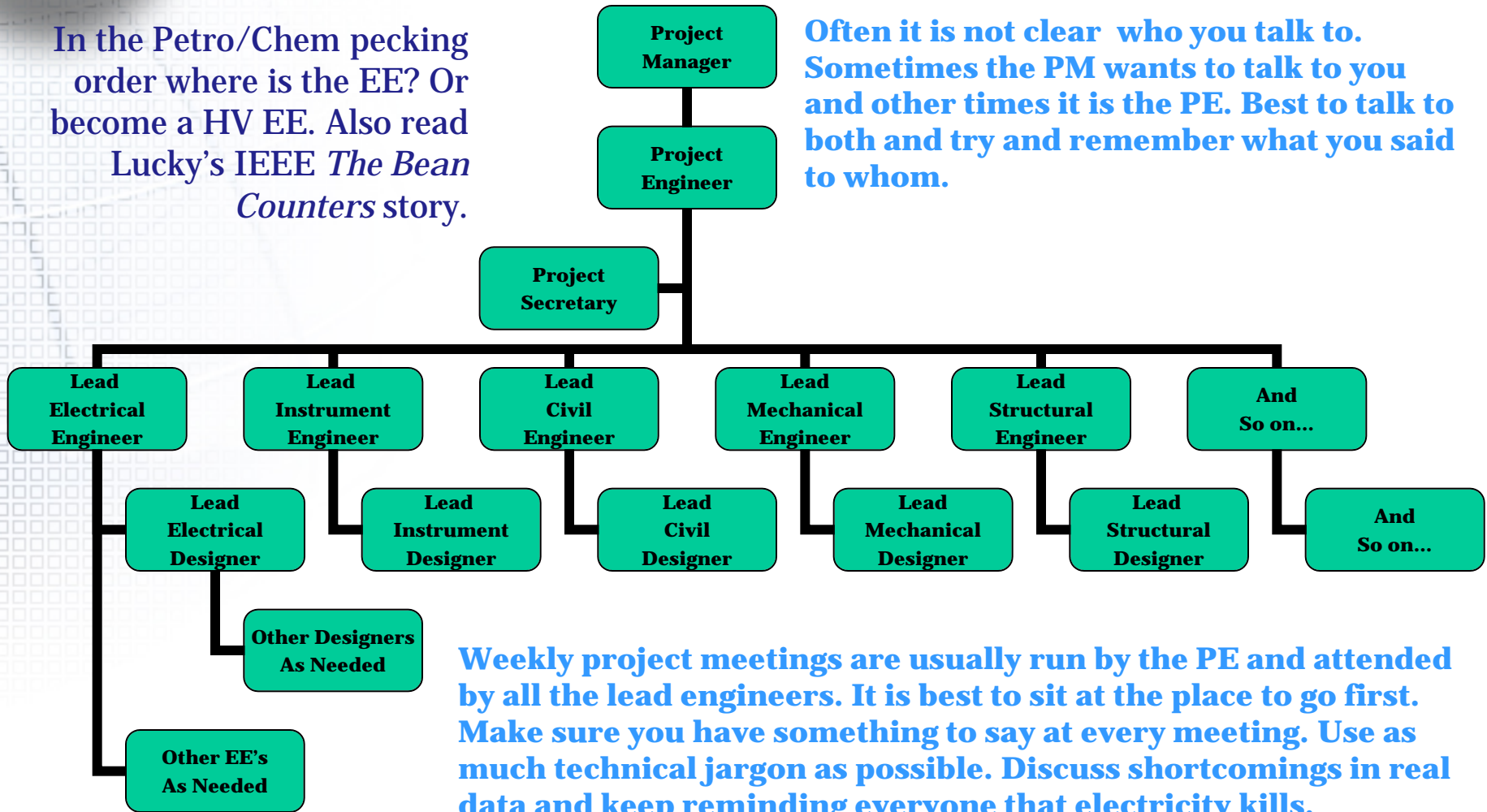

Weekly project meetings are usually run by the PE and attended by all the lead engineers. It is best to sit at the place to go first. Make sure you have something to say at every meeting. Use as much technical jargon as possible. Discuss shortcomings in real data and keep reminding everyone that electricity kills.



# What to do First?

The **lead EE** and the **lead EE Designer** should read through every document that was provided by the End User in the contractual documents.

## WHY?

Because some nugget of good information might/may /could be buried in the wrong location but is directly applicable to the electrical team effort.

This read-through should generate...

A **list of questions and comments** that are necessary for the successful completion of the project.

I.E. **Cover Your Ass (CYA)**. Show that you have read through the provided documents. Document you know what is expected and move forward.



# RFI & CO's

**Even though we don't like it, change is part of the natural project progression. How we handle change is key to a successful project. There are two types of change, internal and external.**

**Internal changes are internal against the EPC contractor. External changes are against the Und User.**

**All change should be handled through a well-oiled Management of Change (MOC) system.**

- 1. Usually the first step is to issue an request for information (RFI) to delve deeper into the question.**
- 2. If a change is needed a change order (CO) is drawn up by the EPC Contractor and presented to the End User's representative. Usually the cost and schedule impact is documented.**
- 3. If approved the change is done. If not approved the change is not done and work carries on.**

**This is classic Cover Your Ass (CYA) territory!**



# What to do Second?

**Get a full size copy of the P&ID's and a selection of color highlighters.**

**Go through the P&ID's highlighting every electrical item or anything to do with electrical engineering and design.**

- **These drawings contain the information necessary to start the **electrical load list**.**
- **These drawings should also contain information on **how motors are controlled and if any data is required from the motor to the DCS**.**





# P&ID's Cont.

**The P&ID's contain the information necessary for electrical and the instrument engineers & designers to do their job.**

**What P&ID's do contain are:-**

- **Induction & Sync motor number, name, BHP or HP**
- **Heat traced lines**
- **MOV Information**
- **Electric induction heater information**
- **Electrostatic precipitators**
- **Brownfield tie-in points (Interface between old and new)**
- **...How these things are controlled (well... maybe)**



# P&ID's Cont.

What P&ID's **do not** contain are considered **other electrical loads** and consist of:-

- **Lighting & receptacle location, type & loads**
- **Building loads including HVAC loads**
- **Instrumentation location & loads**
- **Heat tracing loads & piping location**
- **Equipment location**
- **Relay functionality, selection and communication (if any)**
- **Battery & charger types and sizes**
- **Electrical HV, MV & LV equipment sizing and rating**
- **Electrical schemes like simple radial or M-T-M?**
- **...How these things are controlled**



# P&ID's Cont.

**P&ID's do not discuss or address how electrical loads are to be distributed or assigned the standard terms of Continuous, Intermittent, Standby or Emergency.**

**This activity is left to the Electrical Engineer to develop and propose to the rest of the group.**

**P&ID's give you **half the story**, the **other half** is generated from working with other groups and internally within the electrical team.**

**Simply put, **someone** has to fill in all the missing blanks and figure out where all the numbers come from. And that **someone** is you!**



# EPC Work Quiz

In a **brownfield** site:- do I...

- 1. Copy the existing control schemes (M-T-M or simple radial)?**
- 2. Use the existing equipment manufacturers?**
- 3. Use the existing relays and programming philosophy?**
- 4. Ask for the P&ID's to be changed so I can use the existing operating/control philosophy?**
- 5. Keep on using Mylar's or flip them to CAD?**
- 6. Make drawings look the same as existing ones?**
- 7. Install using existing installation details?**

**Or what???**



# P&ID's Stds

---

**Most companies have gone to the abbreviated way of showing motors on P&ID's since they are a stock item and there were only a few ways motors are controlled. Exceptions are usually dealt with as a one-off.**

[FW P&IDs.pdf](#)



# P&ID's – Small 480V Motors

## DETAIL MC-1

MOTORS UP TO 125 HP AND FROM 125 HP TO 250 HP @ 1800 RPM.

- MOTOR PROTECTION RELAY (MPR) TO BE INSTALLED AT MCC AND INTERCONNECTED TO DCS VIA FIBER OPTIC CABLE.
- LOCAL CONTROL STATIONS SHALL BE PROVIDED AND SHALL CARRY THE MOTOR TAG NUMBER.
- ALL INSTRUMENT TAG NUMBERS SHOWN ON THE IMPLIED DETAILS SHALL CARRY THE SAME CONSECUTIVE NUMBER (PPNNN) OF THE DCS INSTRUMENT TAG (HC-PPNNN) SHOWN ON THE MAIN EFD.

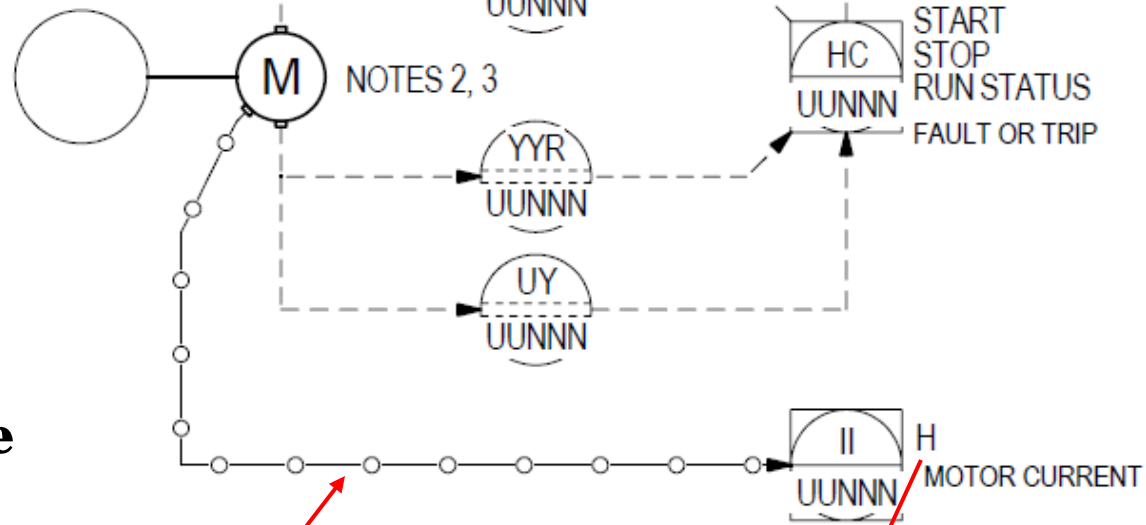
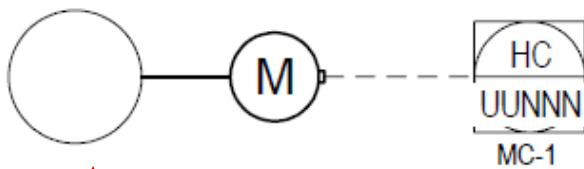

**Note the difference**

SHOWN ON P&ID

IMPLIED DETAIL  
(NOTE 4)

H=High open



# P&ID – The Lingo Demystified



INSTRUMENT FUNCTIONAL IDENTIFICATION (UP TO FIVE CHARS)

SUFFIX (UP TO TWO LETTERS)

CONSECUTIVE NUMBER (THREE DIGITS)

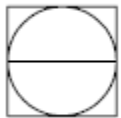

BPCS FUNCTION  
ACCESSIBLE  
IN PRIMARY  
LOCATION

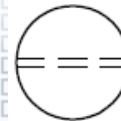

AUXILLIARY LOCATION  
INACCESSIBLE

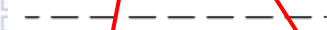

ELECTRICAL SIGNAL

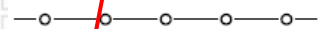

SOFTWARE OR DATA LINK

If it is inaccessible then it is not the field PB.

Basic Process Control System (BPCS) or where the operator sits.

INSTRUMENTS FUNCTIONAL IDENTIFICATION (NOTE 1)					
	FIRST LETTER		SUCCEEDING LETTERS		
	MEASURING OR INITIATING VARIABLE	MODIFIER	READOUT OR PASSIVE FUNCTION	OUTPUT FUNCTION	MODIFIER
A	ANALYSIS		ALARM		
B	BURNER FLAME		USER'S CHOICE	USER'S CHOICE	USER'S CHOICE
C	USER'S CHOICE			CONTROL COMPUTER/AUTOMAN	CLOSE
D	USER'S CHOICE	DIFFERENTIAL OR DEVIATION			DEVIATION
E	VOLTAGE(EMF)		PRIMARY ELEMENT		
F	FLOW RATE	RATIO (FRACTION)			
G	GAS DETECTOR		GLASS / GUAGE (INDICATOR)		
H	HAND(MANUALLY) INITIATED				HIGH, OPEN
I	CURRENT(ELEC.)		INDICATE		
J	POWER	SCAN			
K	TIME OR TIME SCHED.	TIME RATE OF CHANGE		CONTROL STATION COMPUTER/MAN	
L	LEVEL		LIGHT		LOW, CLOSE
M	USER'S CHOICE	MOMENTARY			MIDDLE OR INTERMEDIATE
N	USER'S CHOICE		USER'S CHOICE	USER'S CHOICE	USER'S CHOICE
O	USER'S CHOICE		ORIFICE(RESTRICTION)		OPEN
P	PRESSURE OR VACUUM		POINT(TEST) CONNECTION		
Q	QUANTITY	INTEGRATE OR TOTALIZE			
R	RADIOACTIVITY		RECORD		RUN
S	SPEED OR FREQ.	SAFETY		SWITCH	STOP
T	TEMPERATURE			TRANSMIT	
U	MULTIVARIABLE		MULTIFUNCTION	MULTIFUNCTION	MULTIFUNCTION
V	VIBRATION, MECHANICAL ANALYSIS			VALVE,DAMPER, OR LOUVER	
W	WEIGHT OR FORCE		WELL, PROBE		
X	UNCLASSIFIED	X AXIS	UNCLASSIFIED, ACCESSORIES	UNCLASSIFIED	UNCLASSIFIED
Y	EVENT, STATE, PRESENCE	Y AXIS		RELAY, COMPUTE, CONVERTER	
Z	POSITION	Z AXIS		DRIVER, ACTUATOR OR UNCLASSIFIED FINAL CONTROL ELEMENT	



# Wiring Diagrams

---

**There should be a set of motor drawings to match the P&ID's. For example...**

[480-001.pdf](#)

[480-001 WI.pdf480-XXX-WI.pdf](#)





# Next Steps

The next basic steps are as follows. [Power Supply System Design.pdf](#)

1. **Electrical Load List**
2. **Overall Electrical One-Line Diagram**
3. **NEC Sizing Basics**
4. **Preliminary Electrical Studies**
5. ~~Area Classification Drawing~~ **Another day.**



# Load List

**In the good old days Load Lists were done by hand and then copied on to the Mylar.**

**In Jan 1983, Lotus 123 came along and the Load List moved with the times (WK1). For the past 30 years EE's have relied on spreadsheets for their Load List. This means:-**

- 1. Load List is in a spreadsheet format.**
- 2. Then the Load List data is copied into ETAP, EasyPower, Dapper, EDSA, ASPIN or whatever is used.**
- 3. If I “combine loads” I have to keep track of this.**

**Subsequent changes have to be do twice, once in the Load List and once in the electrical analysis software. **This duplication of effort provides opportunities for error and mistakes to creep in.****



# Load List - Goal

The goal of a load list is to document and tally the electrical loads required to do the project then the EE assigns the loads to specific busses. **Does everyone agree?**

Is there such a thing as a **Standard Load List?**

The answer is **No**. Every EE has their own version even of the same spreadsheet. I.E. EE's love tinkering improving, expanding, tweaking an existing spreadsheet because they can and want to.

What about **ISO 9001**? How is a spreadsheet validated?

**Accredited quality management system.**



# Load List Cont.

## Load List

**Since the P&ID's are available, the EE would start extracting the data from the P&ID's.**

**The Load List shall use the P&ID name & number designations of all motors. All information keys off these P&ID's.**

**Actually from PFD's, not P&ID's**

P-413102A/B & P-413202A/B 

EFFLUENT PUMP

Capacity: 330 gpm

BHP: 57 hp

4 x 100%

P-413103A/B & P-413203A/B

GF RECYCLE PUMP

Capacity: 341 gpm

BHP: 11.3 hp

4 x 100%

P-413104A/B & P-413204A/B

GF FROTH PUMP

Capacity: 35 gpm

BHP: 1.2 hp

4 x 100%

**What is the relationship between BHP & HP???**



# Next Steps – Load List Cont.

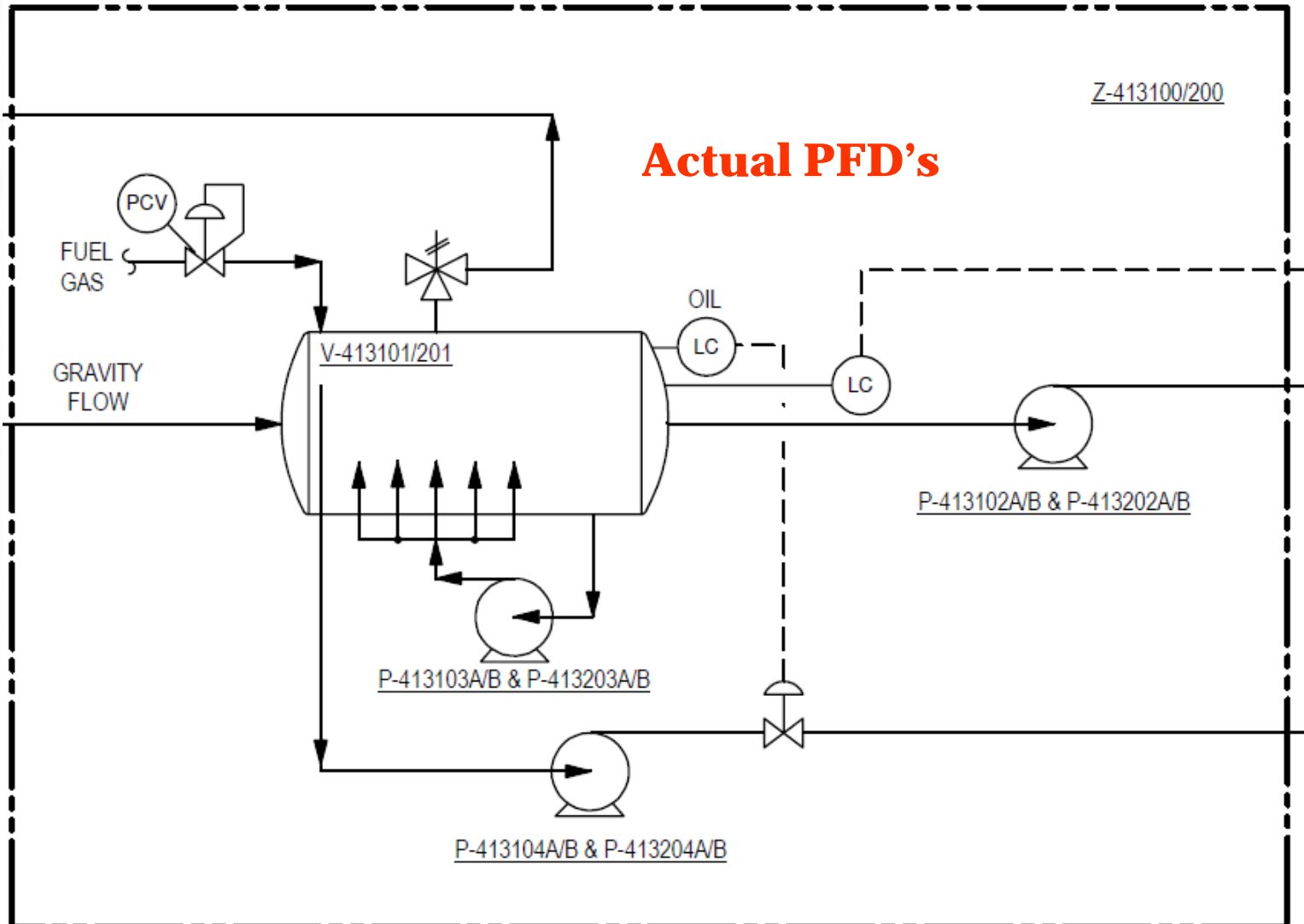



# Load List... Cont.

---

A go-by Load List looks like this. [Load List MTL001.xls](#)  
[MOTORS.XLSCableD.xls](#)  
[MCC-1001B.pdf](#)



# Load List Terminology

Term used	Meaning
Continuous	Loads that normally operate continuously over a 24 hour period. Also see Duty - Continuous NFPA 70-100. Motors should be nameplatted as a <i>Continuous Duty</i> motor.
Intermittent	Loads that operate a fraction of a 24 hour period. Also see Duty - Intermittent NFPA 70-100. Motors should be nameplatted as a <i>Continuous Duty</i> motor. Do not confuse with <i>Intermittent Duty</i> Motors unless required for the application.
Standby	Loads that are on standby or rarely operate under normal conditions. Motors should be nameplatted as a <i>Continuous Duty</i> motor.
Emergency	Loads that run continuously in an emergency situation. Motors should be nameplatted as a <i>Continuous Duty</i> motor.
Diversity Factor	1993 Red Book 2.4.1.3.5 The ratio of the sum of the individual non-coincident maximum demands of various subdivisions of the system to the maximum demand of the complete system. The diversity factor is always 1 or greater. The (unofficial) term <i>diversity</i> , as distinguished from <i>diversity factor</i> refers to the percent of time available that a machine, piece of equipment, or facility has its maximum or normal load or demand (i.e., a 70% <i>diversity</i> means that the device in question operates at its normal or max load level 70% of the time that it is connected and turned on)
Load Diversity	The Red Book nor NEC defines “load diversity.” It is understood that if a term or phrase is not explicitly defined in the NEC, then the reader is to interpret that term or phrase in accordance with common industry usage. However, the phrase “load diversity” does not possess a common industry usage for which a calculated result could be expressed as a fraction less than one.
Demand Factor	The ratio of the maximum demand of a system, or part of a system, to the total connected load of a system or the part of the system under consideration. See NFPA 70-100. The result is always 1 or less. (See IEC IEV Ref 691-10-05)



# Load List Terminology Cont.

Term used	Meaning
Coincidence Factor	The ratio, expressed as a numerical value or as a percentage, of the simultaneous maximum demand of a group of electrical users within a specified period, to the sum of their individual maximum demands within the same period. (See IEC IEV ref 691-10-03)
Coincident Demand	1993 Red Book 2.4.1.3.7 Any demand that occurs simultaneously with any other demand, also the sum of any set of coincident demands
Load Factor	1993 Red Book 2.4.1.3.6 The ratio of the average load over a designated period of time to the peak load occurring in that period. <b>Note</b> that although not part of the official definition, the term <i>load factor</i> is used by some utilities and others to describe the equivalent number of hours per period the peak or average demand must prevail in order to produce the total energy consumption of the period.
Absorbed Load	The expected power that will be drawn by the load. Most loads will not operate at its rated capacity, but at a lower point. For example, absorbed motor loads are based on the mechanical power input to the shaft of the driven equipment at its duty point. The motor is typically sized so that the rated capacity of the motor exceeds the expected absorbed load by some conservative design margin. Where information regarding the absorbed loads is not available, then a load factor (is this load factor the same as Load Factor defined above?) of between 0.8 and 0.9 is normally applied.
Mode	Continuous, Intermittent or standby mode
Load Criticality	1) Normal – run under normal operations, 2) Essential – necessary under emergency conditions, 3) critical loads – safety systems, assisting evacuation
Duty Point	Is the BHP value that a driven load is demanding of its driver (motor, turbine, diesel, etc.,)
Growth Factor	The Projection Multiplying Factor (MF) must be specified in percent. This value is used to indicate future load projection (load reduction or growth) – From ETAP.





# Load List Terminology Cont.

Per IEC - All individual loads are not necessarily operating at full rated nominal power nor necessarily at the same time. Factors  $k_u$  and  $k_s$  all the determination of the maximum power and apparent-power demands actually required to size the installation.

Term used	Meaning
Factor of Maximum Utilisation ( $k_u$ )	Name plate ratings invariably list higher values of current than will be seen in use, motors rarely run at full load, etc. A utilisation factor can be applied to these ratings to establish a more realistic load current, thereby not overestimating the demand
Factor of Simultaneity ( $k_s$ )	Not all equipment runs at the same time; for example one motor may be duty and the other standby. The same applies to installations; for example a group of houses or apartments will not all consume the full design current at the same time. Applying a simultaneity factor takes care of this. Often the term diversity is used and has the same meaning
Diversity Factor	The term diversity factor, as defined in IEC standards, is identical to the factor of simultaneity ( $k_s$ ) used in this guide. In some English-speaking countries however (at the time of writing) diversity factor is the inverse of $k_s$ I.E. it is always greater or equal to 1. However according to IEC IECV ref 691-10-04 Tariffs for Electricity, Diversity Factor is the reciprocal of the Coincidence Factor.
Effective Demand	The magnitude of the demand set up by a consumer, consumer class, or type of load, at the time of peak demand on the supply system or during a given potential peak demand period. Note – In using this term, it is necessary to specify to which level of the system it relates (see IEC IECV ref 691-10-06)
Effective Demand Factor	the ratio, expressed as a numerical value or as a percentage, of the effective demand to the total installed load of a consumer or of a group of consumers or installations. (see IEC IECV ref 691-10-07)



# Load List... Cont.

**The EE and/or the designer goes through the P&ID's and gathers all the electrical data from the documents. The Electrical Group should issue a copy of the Load List to the team to show what you are doing and show you are on the ball.**

**As the P&ID's change, the Load List changes. Load List changes should be issued as often as P&ID changes are issued. This way the Electrical Group is always up-to-date.**

**Think CYA!!!**

**During all this P&ID work, the **other electrical loads** are being added into the Load List to provide a comprehensive Load List of all electrical loads. If loads are not known, best educated guess should be used and updated once data is known. **Call it P – preliminary or F – Final data.****

**The **other electrical loads** should have justification documentation in the project file. **Think more CYA!!!****



# Load List... Cont.

The load list will give an early estimate of the total power consumed (**Greenfield**) or added (**Brownfield**).

**Brownfield:** Find out if existing power is sufficient. If not, what is the way out of this pickle?

**Greenfield:** From the load list can be decided the size of the utility requirements or size and number of generators to install. The size and number of generators or utility incoming power will determine the highest voltage to be used in the system.

**Generator voltages** are typically 13.8, 4.16 or 0.48kV

**Utility voltages** are typically 345, 240 or 138kV

If utility is used then step-down transformers are needed. Step-down voltage is dictated by system design.

System voltages are dictated by motor and load size.

For example...



# Load List Cont.

Motor Size	Voltage
Sync motor 8,000HP – and up	13.8kV
Induction motor 3,000 – 10,000HP	13.8kV
Induction Motor 300 – 5,000HP	4.16kV
Induction Motor 1 – 300HP	480V

**Larger systems usually have several voltage levels while smaller systems and drilling platforms usually have few. There is more flexibility between 13.8 & 4.16kV than between 4160 and 480V**

**At some point you can't get a motor at certain voltages. For example, no one makes a 400HP motor at 13.8kV.**



Too big for 0.48kV and too small for 13.8kV.  
That means I have to go with 4.16kV.



# Load List – A's & B's

As was seen in the P&ID's it is common to have two 100% motors for the same service and are called **XXXXA** and **XXXXB**.

This arrangement typically means piping is designed such that one pump/motor (**XXXXA**) is used for a certain while and then the other pump/motor (**XXXXB**) is swapped over. This two pump/motor arrangement is usually done for reliability and operability.

By regularly swapping over from **XXXXA** to **XXXXB** also means the pump/motor combination wear out at the same rate.

Swapping over usually means **XXXXA** is running, then **XXXXB** is started and allowed to come up to speed and checked out. If everything is okay then **XXXXA** is turned off and **XXXXB** carries on.

Check the SOP for exact sequence.



# Load List – A's & B's... Cont.

To the EE having motors named **XXXA** and **XXXB** means one thing: they need to be on different power systems so that if I loose one system I can flip to the other and keep on going.

For example, if I have 2X100% 480V 50HP motors called P-101A/B then I would put **P-101A** on one 480V MCC and **P-101B** on a separate MCC. This in turn means I have two 480V MCC's (**MCC-A** & **MCC-B**) fed from two sources which in turn means I should have a 480V switchgear using a main-tie-main (M-T-M) configuration.

Keep it simple by using the KISS principle. That means all A's go on the A side and all the B's go on the B side.

If there are three motors, **XXXA**, **XXXB** & **XXXC** then two go on one side and one on the other. EE's choice on sides. Four motors it is two and two.

With three motors, check with process as there might some process reason for which motors go on which side.



# Load List – A's & B's... Cont.

The **other electrical loads** are usually assigned between the 480V MCC's (**MCC-A** & **MCC-B**) with some semblance of reason. If the client asks why did you do this or that, what documentation do you have in the project files to back up your choice or decision. **Think more CYA!!!**

A **Brownfield** site can present challenges such as no space in the existing MCC's; additional loads push the equipment over the sht-ckt or ampacity ratings... What are you going to do? Can you add in new MCC's? Switchgear? Change out the incoming xfmr? (**will that impact arc flash???**) Add a new PCR? Rework the incoming power or system?

Every problem requires at least two, preferably three possible solutions. EE's are paid big bucks to solve problems, not give up! So get thinking: and now you know why **Brownfield** work is more challenging.



# Load List – A's & B's Cont.

Once we talk about a M-T-M system the common understanding is, power to both main breakers with the tie breaker open. This is the normal operating configuration.

If power is lost to one main breaker the loads are transferred to the other side by opening the breaker that has lost power and close the tie.

With this understanding that means the main bus and transformers have to be sized to carry the entire load on one side.

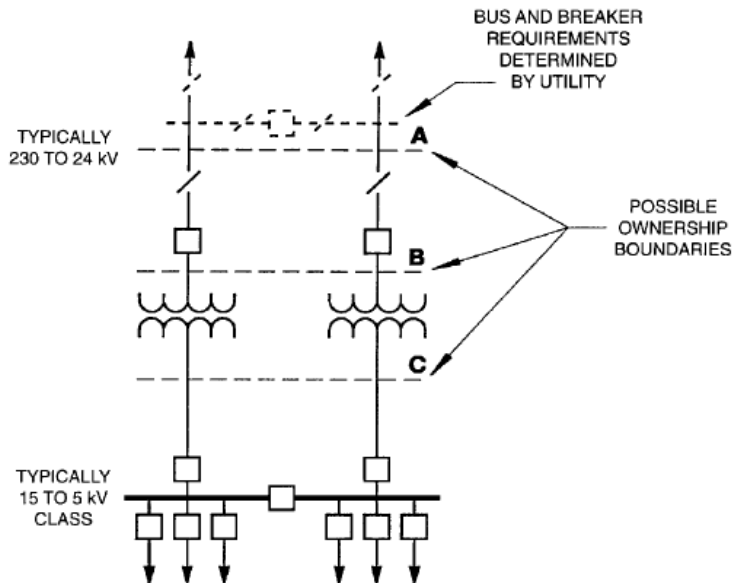





# Load List – A's & B's Cont.

**In this little example we have seen the natural progression from the Load List to selecting voltages and on to selecting switchgear and transformer sizes.**

**This is more fully explained and covered in the **IEEE Red Book** chapters 2 (**system planning**) & 3 (**voltage considerations**).**

**Whatever you do have a reason, justification, standard, paper, document to justify your position. If not, why are you doing it? An EE never say, “I’m doing it because Joe said so.” Go and find out why Joe says so. Get his justification, etc., and put it in your file.**

**Don’t rely on the person who says, “Trust me! Do it this way and you will be just fine!”**

**Think more CYA!!!**



# Load List – Cable Sizing & VD

**Most decent electrical load lists have been expanded to include an automatic first pass at sizing cables for each load.**

**To do this it is required to define the allowable voltage drop (VD) of the system and the motor cable length.**

**NFPA 70 2014 has many references to two types of voltage drop. One being a 5% overall voltage drop and the other being a 3% circuit voltage drop.**

**These two values are *generally accepted* as the design targets to be met.**

**Therefore, the facility should have an overall voltage drop of  $\leq 5\%$  with motor loads having a voltage drop  $\leq 3\%$ . This is eminently achievable by correct selection of cables and judicious placement of equipment.**



# SPEL = Horsepower

The screenshot displays the SmartPlant Electrical software interface. The title bar reads "SmartPlant Electrical - Plant Demo SPEL / Unit 10 - [Document1 - SLD Completo]". The menu bar includes "File", "Edit", "View", "Actions", "Tools", "SmartPlant", "Reports", "Window", and "Help".

On the left, there are three panels:

- Electrical Index 1:** A tree view showing "Electrical Equipment" with sub-categories like "Loads", "Static Electrical Equip", "Miscellaneous Electrical", "Offsite Power Supplies", "Generators", "Battery Banks", "Converting Equipment", "Power Distribution Equipment", "Instruments", "Signals", and "Wiring Equipment". A list of motor tags (e.g., 1618MTR-0101 to 1618MTR-0204) is visible below.
- Electrical Equipment 2:** A tree view showing "Plant" with sub-categories like "G-Plus", "G-Sec", "CG1-TR-01", "CG2-TR-02", "TR-5-sec", "TR-SEC", and "C-TRC".
- Reference Data Explorer 1:** A tree view showing "Electrical Equipment" with sub-categories like "Loads", "Motor", "Static Electrical Equip", "Miscellaneous Electric", "Offsite Power Supplies", "Generators", "Battery Banks", "Converting Equipment", "Power Distribution Equipment", "Relay Functions", "Instruments", "Wiring Equipment", "Typical Circuits", "Protiles", "Lookup Tables", "Typical Blocks", "Typical Schematics", "Terminal Strip Configurations", and "Connection Types".

The central area shows a detailed electrical diagram on "Sheet1", featuring a complex network of lines, busbars, and equipment symbols.

On the right, the **Properties** panel is open for a selected motor, "Motor - 1618MTR-0201". It displays various parameters:

- General:** Identification, Load and Elec, Allow Publish Flag (False), Asynchronous Sp, Average Active L, Brake Power, Consumed Active, Consumed Appen, Consumed React, Demand Factor, Drill Down Enable (True), Efficiency 75 Low (0.947), Efficiency Full Lw (0.947), Efficiency Half Lw (0.932), Efficiency Operat, FLA Calculation F (Calculated), Frequency (60 Hz), Full Load Current (8.8 A), kVA per HP Fact, kVA to HP Ratio, LRC Code Letter, LRC to FLA Ratio (6), Minimum Require, Motor Rated Pow (655 kW), Number of Phase (3), Operating Factor (1), Particular Active I, Particular Appen, Particular Power, Particular Reactiv, Phase Arrangem, Phase1 Usage (In Use), Phase2 Usage (In Use), Phase3 Usage (In Use).



# SPEL... Cont.

**The SmartPlant family includes**

- **SmartPlant 3D**
- **SmartPlant P&ID**
- **SmartPlant Electrical**
- **SmartPlant Instrumentation**

**SmartPlant Electrical (SPEL) can pull P&ID data from SmartPlant P&ID. Can integrate with SmartPlant Instrumentation . Can export/import electrical data to/from ETAP.**

**SPEL is the first truly integrated challenger to the lock Lotus 123 put upon the Petro/Chem industry 30 years ago.**

**The question is, are you ready to move into the 21<sup>st</sup> century? Or are you happy living the life of a 20<sup>th</sup> century Luddite?**

**The *Luddites* were 19th-century English textile artisans who protested against newly developed labor-saving machinery.**



# e-DPP 3.0



e-DPP was reborn ! That's Renaissance !

## e-DPP 3.0



e-DPP has been experienced as a leader of plant electrical engineering tools and now vastly upgraded. The new and enhanced features of e-DPP 3.0 are described here. At the end of this brochure, all the major features of the previous version e-DPP 2.5.2 are described as well. If you are new to e-DPP, please refer to that first.



Load Summary **Enhanced!**

---



# Cable Routing - 1





# Cable Routing - 2

**Transformers in a row. Two 13.8kV feeders jumpering to every other transformer.**

**13.8kV/480-277V**

**Transformers.**

**WHY???**

**The big man did not like a bunch of small substations. He wanted one big one. This is it!**

**Issues were duct bank heating and voltage drop.**



**18 13.8kV-480Y/277V Xfmrs in a row. That is 9 sets of M-T-M 480V swgr which feeds the 480V MCC's.**



# Cable Routing - 3



**Note the xfmrs have blast walls between them.**





# Overall One-Line

**Step #2 is to take the load list and start creating an overall one-line diagram that best suits the project. As usual there are differences between a Brown and Greenfield project.**

**Brownfield:-** The main issue is dealing with existing system/equipment and trying to fit in the new loads. new loads will change the dynamics of the entire electrical system.

**Greenfield:-** A Greenfield starts with the question of, where is power coming from or is the facility self generating with black-start capability? Then follow established system designs.

[Overall.pdf](#)



# The Overall One-Line Cont.

As usual there are differences between a **Brown** and **Greenfield** project.

Brownfield	Greenfield
Do new loads fit existing voltage ratings?	Utility power from?
Is there spare space?	138, 240 or 345kV ring substation?
Equipment Amps & Sht Ckt ratings adequate?	What voltage levels? 13.8, 4.16 & 480?
Not enough Amps from the utility	Simple radial or going classic M-T-M at each level?
Need really soft starters	Cross the line starting.
Existing mylars	CAD
Modifying swgr for relays	Relays and ENMCS

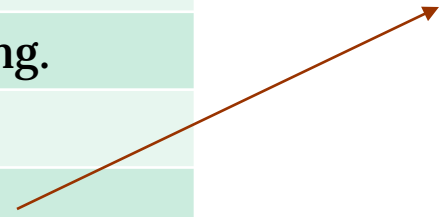



# Overall One-Line... Cont.

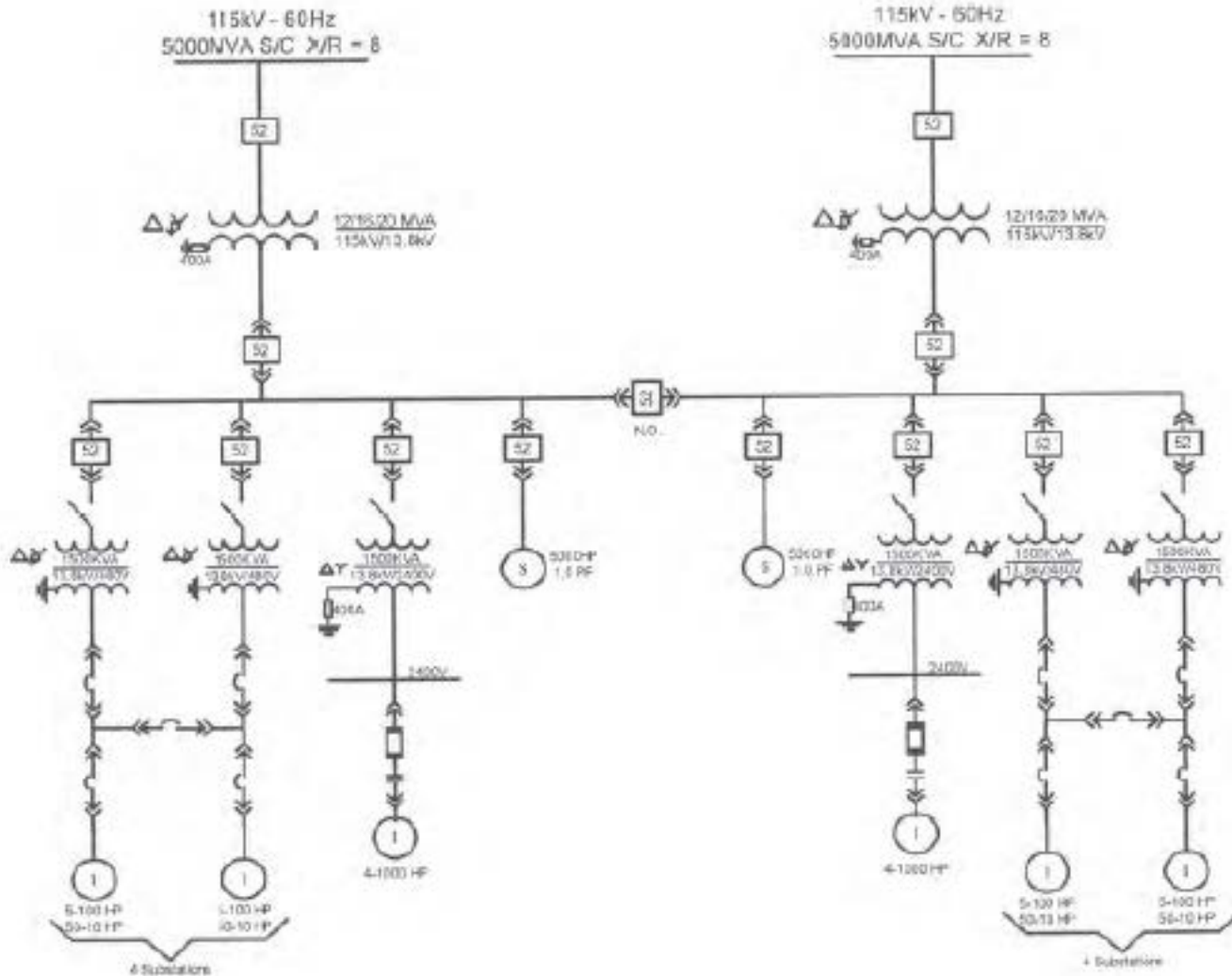

Figure 2-1. Preliminary one-line diagram

From GET-6600G



# Basic Protective Devices

**If the client does not have LV or MV motor or load protection guidelines, where do you turn to for authoritative guidelines? Try the following.**

- 1. IEEE 141-1993 (Red Book) Chapter 5**
- 2. IEEE 242-2001 (Buff Book) Chapter 10**
- 3. GE - The Art of Protective relaying (**not** The Art & Science...)**
- 4. GE – Basic Relay Application Guide**[GET-8048A Basic Relay Application Guide.pdf](#)
- 5. Westinghouse – AC Motor Protection Guide**

**All of the above only reference equipment protection, they do not address data gathering or communication. In a **greenfield** this might not be enough while in a **brownfield** this might be perfect. *What is in the contract?***[Tambora\\_2.pdf](#)



# Basic Protective Dev. Cont.

Figure 2-3. Developed one-line diagram.

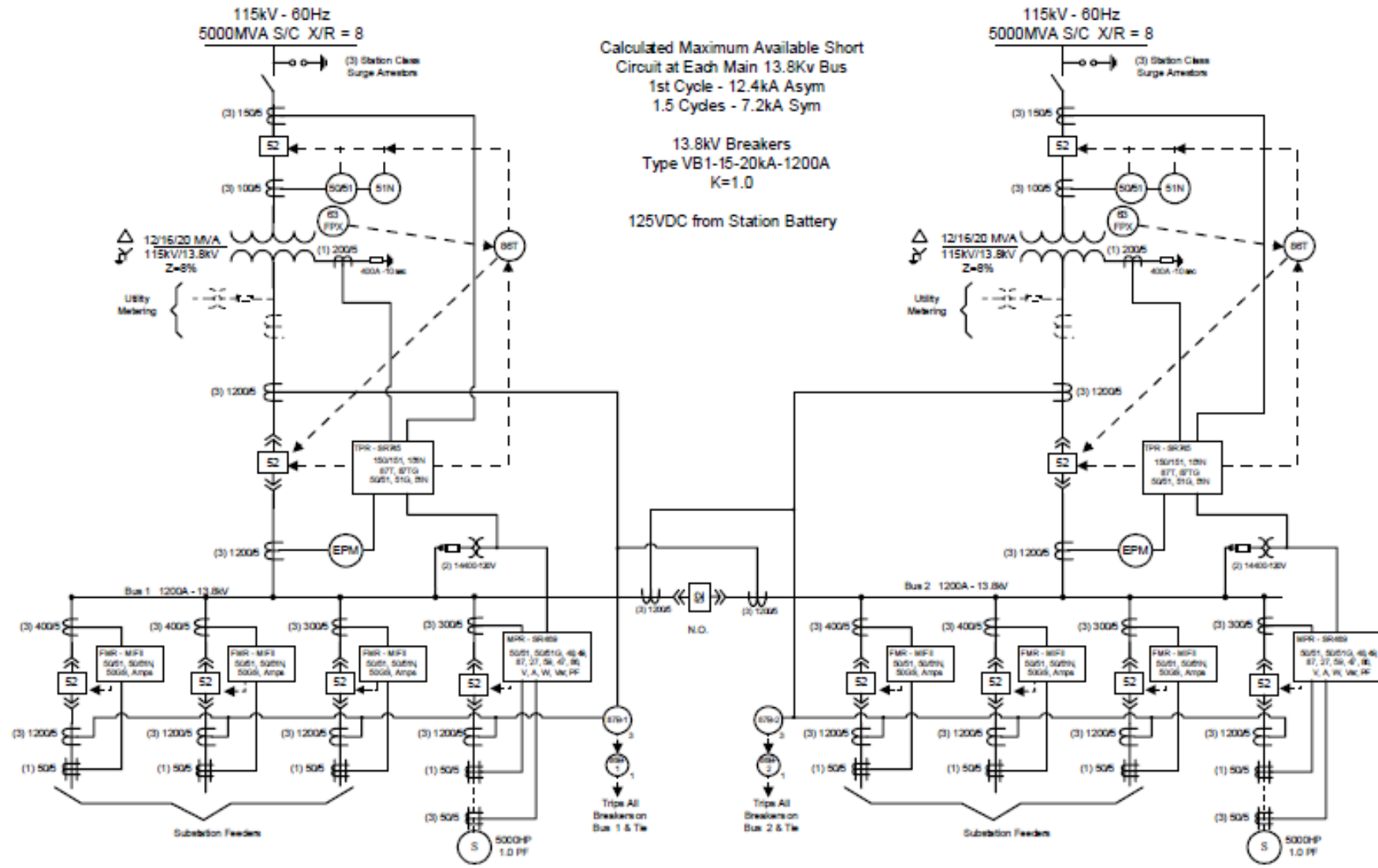



# Basic Protective Dev. Cont.

**This is  
equipment  
protection only.**

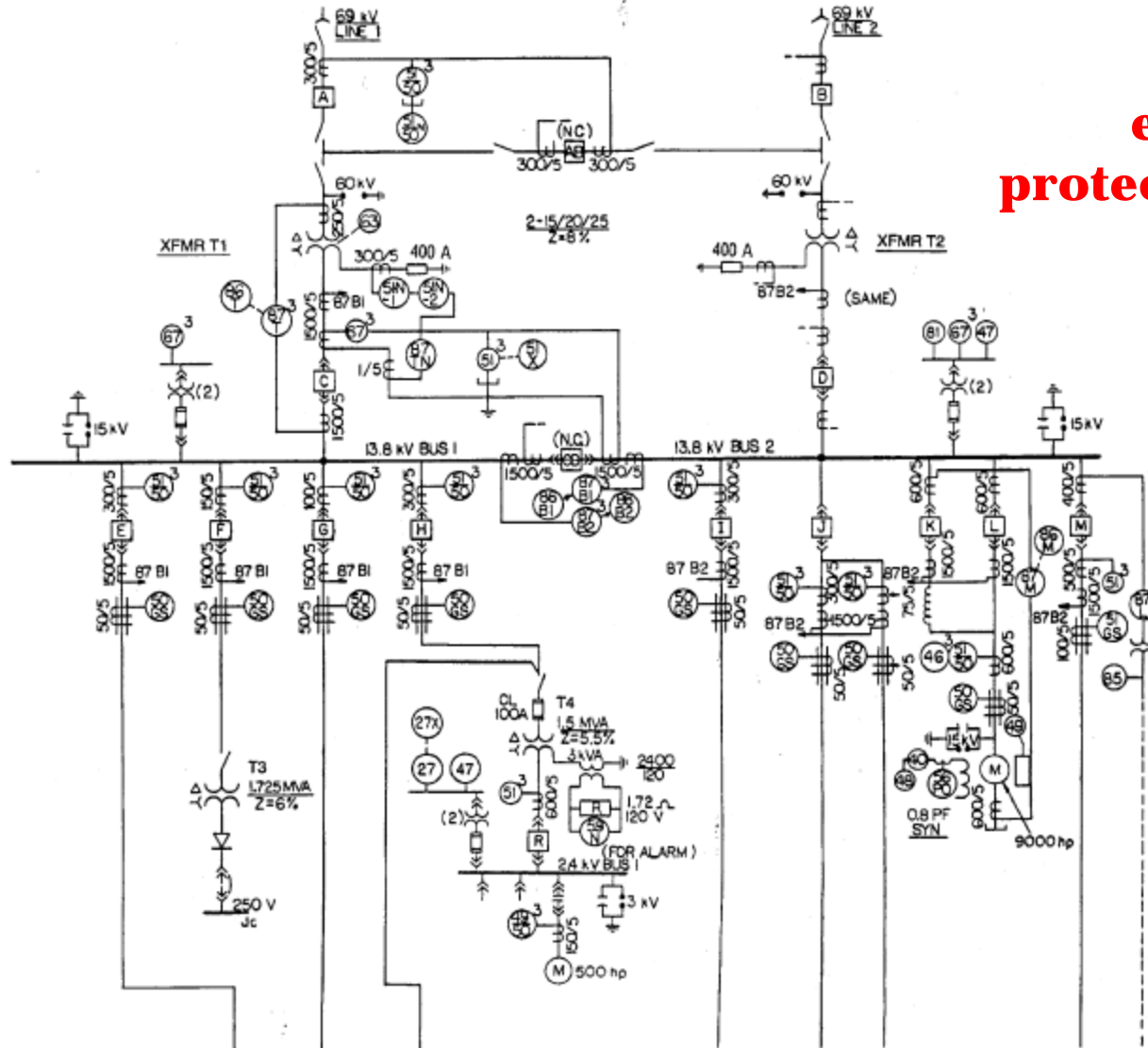



# Basic Protective Dev. Cont.

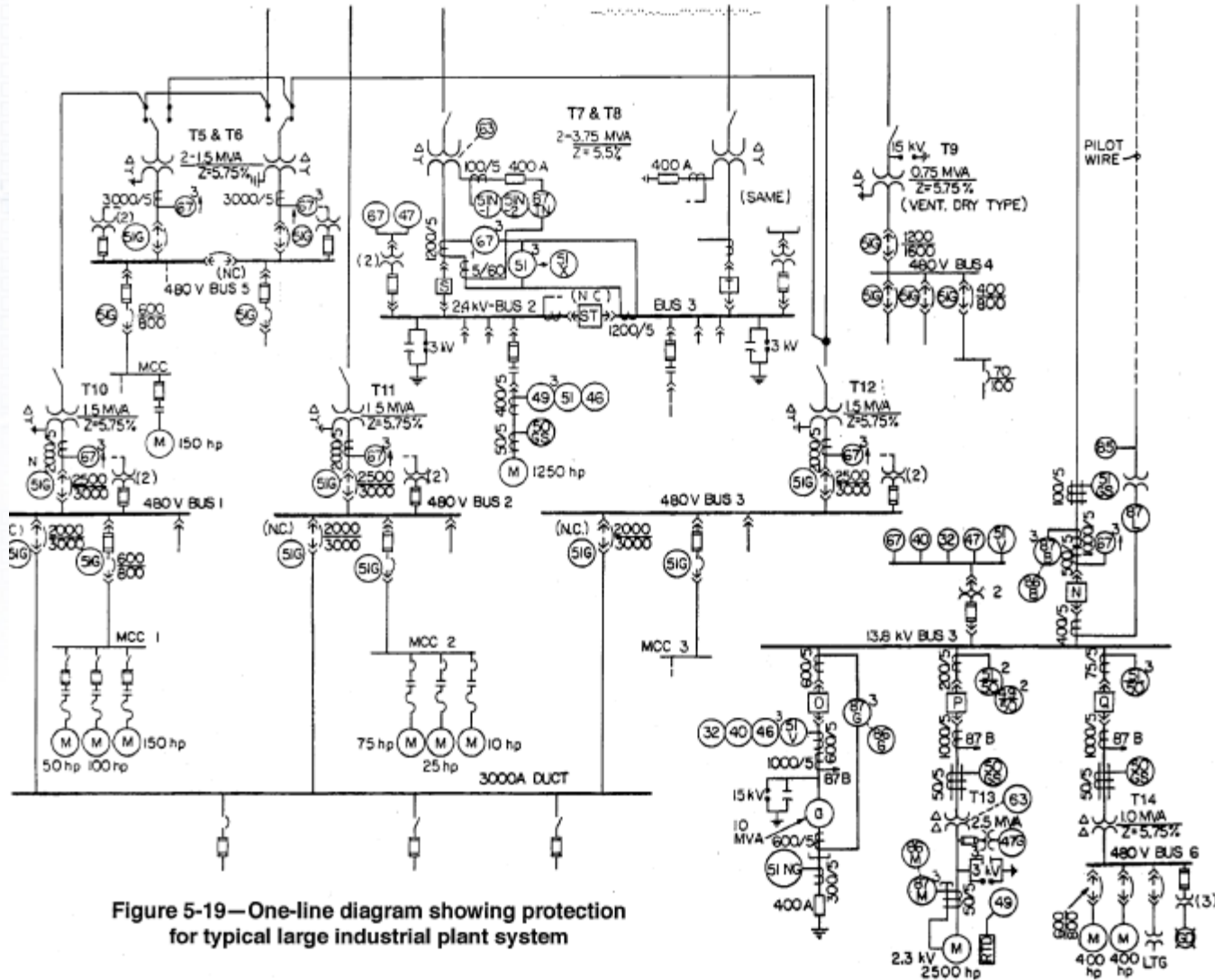



# NEC Sizing Basics

**Step #3. In North America Petro/Chem plants are built in accordance with NFPA 70-2014 (NEC) as far as practicable.**

Item	Clause
480V Motor ampacity	430.6 (Not necessarily nameplate value)
480V Adjustable Voltage Motor Cable	430.6(C) (Up to 150% FLA)
480V Motor Cable	430.22 (Typ. 125% FLA)
480V Load Cable	210.19 read(A)(1) (Possibly 125% FLA)
480V MCC bus size	430.24 (See the NEC formula)
480V Bus/cable to the 480V MCC	430.25
480V M-T-M Swgr	Match summation of MCC bus sizes (really?)
XXX-480Y/277V xfmr	Size for ONAN/ONAF/ONAF to match 480V swgr

**What are the guidelines?**

**This is a go-by: not Gospel. Do you agree/Disagree? Whatever you do, document to justify your position. Think more CYA!!!**

**The IEC world is different.**





# NEC Sizing Basics... Cont.

**Iconic Question: The **brownfield** site in New Mexico was originally built in 1965, updated in 1980 and again in 1995. My small upgrade project will be installed in Q1 2014. it includes the following.**

- 1. Reusing existing buckets in existing 1965 MCC's**
  - 2. Installing new MCC's fed from 1980 480V swgr**
  - 3. Adding more heat tracing load into the 1980 MCC's**
  - 4. Adding ground fault to size 3 and above buckets in the 1995 MCC's**
  - 5. All dwgs and calcs are New Mexico PE sealed**
  - 6. The local fire marshal -Uncle Bob- is the authority having jurisdiction. He has one volunteer fire truck and no EMT.**
- Which NFPA 70 am I supposed to comply with?**



# Basic Electrical Studies

**Step #4 is the running of some basic studies to see if what we have done actually has a chance of working. This are usually called initial studies and are done early in the project. They may or may not be the same as the client did back in Select. The basic studies are as follows.**

- 1. Load Flow**
- 2. Short-Circuit**
- 3. Motor Starting**



# Sht-Ckt Studies

**There are several short-circuit calculation methods based on the ANSI/IEEE and IEC Standards, for both AC three-phase and single-phase networks. The following short-circuit calculation methods can be used.**

**AC ANSI/IEEE (separate R and X, as per ANSI/IEEE Standard)**

**AC Classical (Z complex method, X/R from complex Z)**

**AC IEC 60909**

**AC IEC 61363**

**AC Single Phase**

**DC Classical**

**DC IEC 61660**



---

***Questions ?***