

THE REALITY OF HIGH-RESISTANCE GROUNDING

J.R. Dunki-Jacobs
Senior Member IEEE
General Electric Co.

"Copyright Material IEEE"

Conference Record 76CH1109-8-IA

Paper Number PCI-76-6

THE REALITY OF HIGH-RESISTANCE GROUNDING

J.R. Dunki-Jacobs
 Senior Member IEEE
 General Electric Co.
 Schenectady, N.Y.

Introduction

Ever since the high-resistance (hi-R) system neutral grounding concept was introduced some 20 years ago, its popularity has grown with the availability of hardware to detect and locate the first ground fault. Continuously process plant engineers were the prime beneficiaries of the hi-R grounding concept for the obvious reasons that their process would no longer be subject to unscheduled shutdowns associated with solidly-grounded systems, while the potential line-ground over-voltage hazard associated with ungrounded systems was greatly reduced. The introduction of NEC Article 230-95 in 1971, requiring ground-fault tripping (not necessarily selective) of most 480-volt and 600-volt solidly grounded systems, accelerated the broad acceptance of hi-R grounding of low-voltage systems. Understandably, the concept was also promoted for use in 5-kV and 15-kV systems. Successful implementation, however, fell short of expectations on 15-kV systems.

It is not surprising that a considerable number of articles and papers have been written on the subject of hi-R grounding. Reflecting the general enthusiasm, these writings began to make undue claims for the hi-R grounded systems in comparison with alternate modes of grounding.

Realistically, the hi-R grounding concept has significantly contributed to the improvement of system continuity. To take full advantage of the concept and to avoid disappointments, this paper will attempt to more soberly identify the broad application areas as well as offer qualifications regarding the application of the hi-R grounding concept.

High-resistance Grounding Experience

As originally conceived, the intent of hi-R system neutral grounding was twofold:

1. Suppress transient line-ground overvoltages by sizing the neutral resistor such that its current during a line-to-ground fault is slightly higher than the system charging current ($I_R > 3I_{co}$). See Figs. 1 and 2.
2. The faulty system component need not be disconnected immediately in case of a ground fault. Instead an alarm would indicate the occurrence of the ground fault.

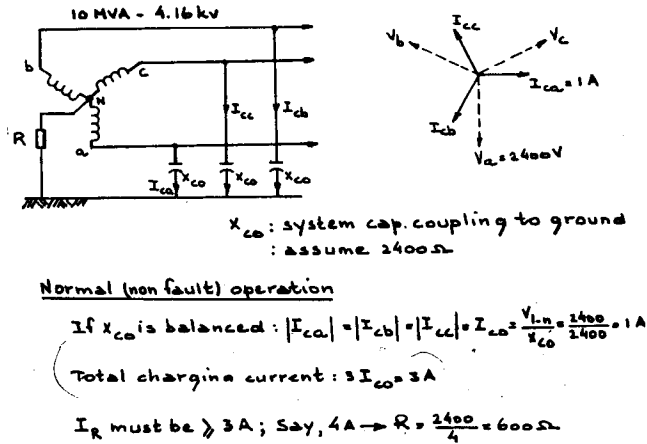

Fig. 1. Voltage and charging current relationship in high-resistance neutral grounded system during normal operation.

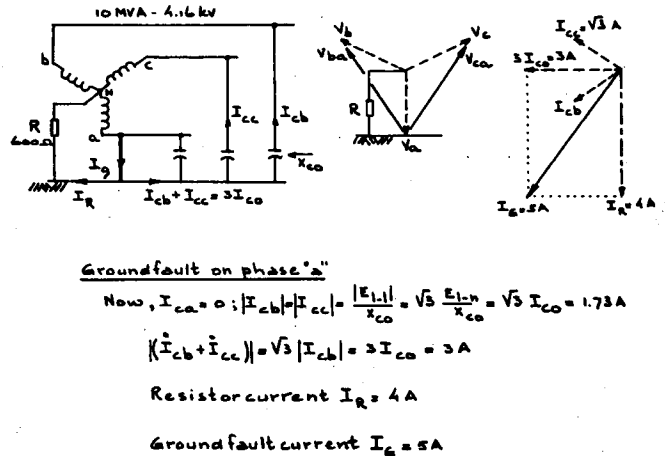

Fig. 2. Voltage and current relationship in high-resistance neutral grounded system during a ground fault on phase "a".

Hi-R system neutral grounding results in additional benefits such as;

1. The reduction of flash hazard to personnel for accidental line-to-ground "screwdriver" faults.

2. The reduction of potential equipment burn-downs due to sustained low-level arcing ground faults, as experienced on 480-V and 600-V solidly-grounded neutral systems, served from delta-wye transformers protected by primary fuses.

A survey indicates that experience with hi-R grounding has been quite favorable, particularly in 2400-volt and low-voltage systems. A patented method for an improved fault locating technique using the pulsing principle contributed greatly to the success and acceptance of hi-R grounding. (Fig. 3). It is estimated that in the last 15 years some 1000 hi-R neutral grounded systems have been placed in operation at 480 and 2400 volts.

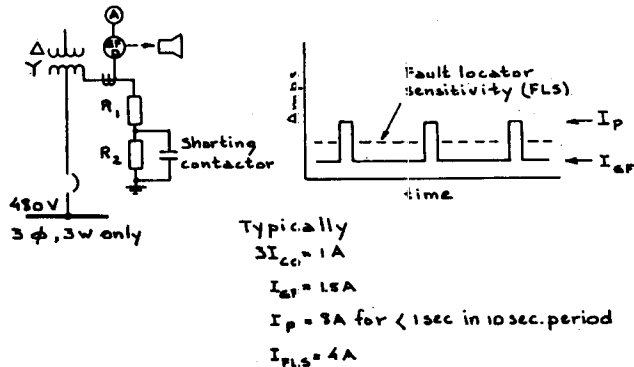

Fig. 3. Concept of high-resistance grounding with cyclic pulsing fault-locating principle.

Because of the initial favorable experience, the hi-R grounding concept was soon extrapolated into higher voltage and more extensive systems with considerably higher charging currents. This, of course, forced an increase in ground-fault current to satisfy the $I_R \geq 3I_{CO}$ criterion. The higher burning damage at the point of fault often was sufficiently increased to cause fault escalation before the first ground fault could be located and the faulted circuit removed. This situation was particularly experienced in 15-kV systems and to a lesser degree in 5-kV systems. In fact, there is reason to believe that there are no successful 13.8-kV hi-R grounded systems in operation which rely only on an alarm signal.

This fault escalation experience resulted in the logical decision to trip rather than alarm in response to a ground fault. Additional very sensitive ground-fault protection was then required on each feeder circuit to cause opening of the faulted circuit breaker. This solution, however, has the following disadvantages:

1. Sensitive (2 amps or less) ground-fault relays have only recently become available in limited offerings. These solid-state relays operate essentially instantaneously and are more costly than the more conventional ground-sensor relays with a sensitivity of about 15 amps.
2. Ground-fault current selectivity is for all practical purposes not achievable, except for a zone-selective interlocking system. In this system, a remote ground fault will be sensed by the closest upstream

ground-sensor which not only trips its circuit breaker or contactor but also blocks the next interrupter upstream from tripping for a preselected time. This next upstream ground sensor not only provides back-up protection but will also operate instantaneously for a fault in the intervening zone. These zone-selective interlocking systems are, of course, more costly.

3. The sensitive instantaneous relays are likely to operate falsely on downstream multiphase faults. Such faults may be in the range of 10,000 to 50,000 amps. Depending upon the basic relay sensitivity and on how well the three conductors are centered, the window CT may produce sufficient current to pick up the sensitive relay and cause circuit breaker tripping. The information required to evaluate the extent of this problem is, however, seldom available.

4. The relay must be set above the charging current of the downstream circuits to help assure that it will not operate falsely for external ground faults (Fig.4).

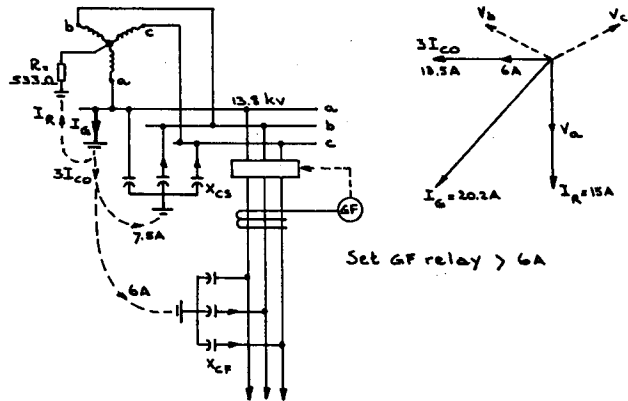

Fig. 4. Illustration showing reason for setting sensitive ground-fault relays above the charging current ($3I_{CO}$) of downstream feeder circuit.

Hence, there resulted two hi-R grounded systems:

1. The original hi-R grounding concept, using an alarm indication, to prevent unscheduled shutdowns.
2. A hybrid hi-R grounding scheme accepting unscheduled shutdowns, uniquely applied to medium-voltage systems to trip the faulted-feeder circuit breaker to prevent escalating an unremoved ground fault into a very damaging multiphase fault. If unscheduled shutdowns are accepted, the conventional low-resistance (50-800A) neutral grounding mode is superior for reasons detailed later.

The Introduction of Hybrid Hi-R Neutral Grounding Systems

Hybrid hi-R grounding became essential only in medium-voltage systems for the reason that on larger systems the charging current is large. As a consequence, the burning damage is extensive and can not be tolerated for even a brief length of time. Reference 2 reports that a 13.8-kV system supplied through a 15/20/25 MVA transformer had a measured charging current of 13.5 amperes (Fig. 4). Assuming a 15-amp grounding resistor, the ground-fault current could reach a magnitude of $\sqrt{13.5^2 + 15^2} = 20.2$ amperes.

Since the described system is not uncommon, it is reasonable to conclude that the 15-kV class systems in general can only be hybrid hi-R grounded. A further objective evaluation, to be detailed later, suggests that most 15-kV class systems should preferably be low-resistance grounded between 50 and 800 amps.

In the absence of recognized and reliable industry data, present indications suggest that the original hi-R grounding concept (alarm only) can be successfully applied on medium-voltage systems if the ground-fault current does not exceed about 8 amps. This translates to a charging current ($3I_{CO}$) of about 5.5 amps. This

qualified limit should not be construed to mean that ground faults of a magnitude below this level will always allow the successful location and isolation before escalation occurs. It should be noted that the 5.5A limit easily can be exceeded with motor surge capacitors which contribute considerably to the total charging current. A typical 0.5 microfarad surge capacitor contributes 0.78 amps at 2.4 kV or 1.35 amps at 4.16-kV. These currents represent ($3I_{CO}$) values.

In the low-voltage area, charging currents are generally around 1 to possibly 2 amperes. Further considering the low driving voltage, 277 volts in 480 volt systems, burning damage is minor. Fault escalation is therefore not considered likely. It is, however, possible that, due to full line-line voltage appearing on the unfaulted phases, a second ground fault may develop on weak insulation on one of these phases. The resulting phase-to-ground-to-phase fault may trip as many as two feeder breakers on phase overcurrent. Hence in low-voltage systems, it is not fault escalation but a multiphase fault that may jeopardize the success of the alarm-only hi-R grounding concept, although experience indicates that this possibility is remote. Prompt location and removal of the first ground fault must be stressed, to insure successful operation of the hi-R grounding concept.

The Effect of High-resistance Grounding on System Components

Allowing a ground fault to persist for an unspecified length of time subjects the line-to-ground insulation on the unfaulted phases to full line-to-line voltage (Fig. 2). On the low-voltage systems this higher voltage should be of lesser importance than in medium voltage, that is 5-kV and above systems. As already described, the use of alarm only hi-R grounding should not be considered on 13.8-kV systems.

The *cable insulation* level is based on the system line-to-line voltage and further assumes that the line-to-ground voltage will not exceed the corresponding line-to-neutral voltage except for some brief intervals. In hi-R grounded 480- and 600-V systems, 600-volt rated cables can be utilized. The NEC table 310-34 specifies a minimum insulation thickness for shielded, solid dielectric insulated conductors, rated 2001 to 5000V of 90 mills. The cable industry offers 5-kV, UL listed cables identified as NEC-MV90, which are suitable for use on high-resistance neutral grounded systems operating at both 2.4 and 4.16 kV.

The effect of the grounding mode on *surge arresters* is of a different nature. Surge arresters are rated on the basis of the maximum 60 Hz voltage at which they may be expected to reseal against, after having sparked

over. In ungrounded systems or *any* resistance (or reactance) grounded system, this voltage is the full line-to-line voltage. Therefore, the proper surge arrester rating is the lowest standard rating which exceeds the line-to-line voltage and is referred to as a 100% arrester. Solid system neutral grounding restrains the neutral shift associated with line-to-ground faults such that typically 80% arresters may be used. The lower rated arresters provide correspondingly lower surge voltage levels, thus better surge protection. In other words, the hi-R grounded system is no more adversely affected than is the low-resistance grounded system.

The effect of full line-to-line voltage appearing on the unfaulted phases of all other system components, such as *motors, controllers, switchgear, transformers and capacitors* does not appear to require special consideration. Applicable ANSI standards only refer to a dielectric test at a voltage equal to two times rated voltage plus 1000 volts for a duration of one minute.

Motors, as an example, will for the duration of a hi-R ground fault be exposed to higher voltages to ground on the unfaulted phases. While it should be expected that some life may be sacrificed, motors are not considered to be in imminent danger of sudden failure. In the lifetime of a motor, these higher voltage exposures are extremely limited, which may explain the tacit approval to operate motors on hi-R grounded systems.

It may be of interest to speculate on the probability that (life) (volts²) is a constant, which relates to the expectation that one hour of operation at $\sqrt{3}$ times rated voltage equates to about 700 hours of operation at unity (rated) voltage. This estimation becomes, however, invalid for low voltage.

Probable Failure Mode of Motor Windings

Motor designers do, however, express concern about the indefinite persistence of a hi-R ground fault in a motor winding. One of their concerns is that the persistence of the ground fault may damage the turn insulation to the extent that a turn-failure occurs, resulting in a shorted turn fault current of many times rated current. It should be realized that line currents as seen by phase-overcurrent relays are hardly affected by this current since the imbalance may be only one to two percent. Another concern is that the winding ground fault may have been precipitated by heating associated with a turn-insulation failure preceding the ground fault. In either event, the fault current in the short-circuited turn is likely to produce local heating and damage the ground insulation to the degree that the fault escalates to a phase-to-phase fault, causing considerable motor damage. It is reasonable to assume that ground-fault sensing, followed by immediate tripout, prevents such escalation. It is recognized, however, that the user may accept the risk of escalation, based on an overriding process continuity requirement.

From a motor point of view, the success of hi-R grounding is to a large extent determined by the *maximum fault-removal time* and *minimum ground-fault escalation time* as it applies to a particular winding insulation and its location. Both may be widely variable while little is known about the mechanism which

affects the fault-escalation time. In actual installation, only the end result can be observed. It is equally true that developments leading up to the fault cannot be monitored. In laboratory tests, the true operating conditions are extremely difficult and expensive to simulate.

In an effort to learn more about the effects of low-level ground faults in a motor winding, a limited series of tests was made using a 4-kV form-wound motor coil positioned in a steel sleeve simulating the coil slot (Fig. 5). The sample model does not truly reflect actual conditions for the following reasons:

- the coil did not see the usual magnetic flux
- the coil was not impregnated
- the coil did not carry current; its operating temperature was about 20 C
- the sleeve provides only a limited heat sink for the fault energy

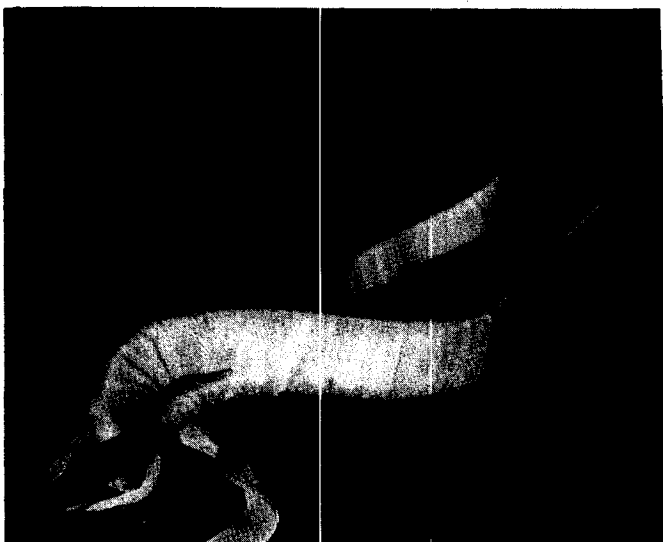

Fig. 5. Motor test coil with metal sleeve to simulate coil slot.

Recognizing the limitations of the simulation, the result of one test may be of interest (Fig. 6). The strand insulation measured 20 megohms prior to the test. A 1/4 inch slit was cut on the coil side through the insulation down to the copper strand. It is interesting to note that no insulation breakdown was evident even when full voltage (2400 volts) was applied.

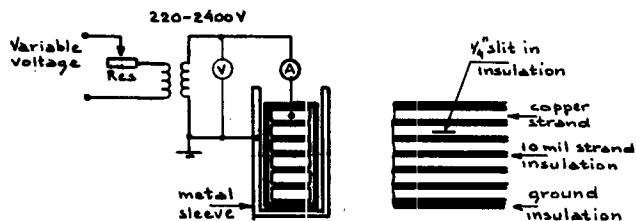

Fig. 6. Ground-fault simulation test circuit using 4-kV, two strand, multiturn coil in metal sleeve.

A drop of water was added to stimulate the fault current. The resistor was adjusted to allow 3A to flow in the 2400-volt winding with this winding short-circuited. The voltage was gradually raised until the sinusoidal voltage, as observed on an oscilloscope, changed to a jagged flat-top voltage wave, indicating that an arcing fault was in progress. The heat dissipated in the arc was estimated to have a value of 300-800 watts. In less than one minute, burning and smoke were observed (Fig. 7). The escalation from an arcing to a solid fault was evidenced by a considerable reduction in voltage of sinusoidal character which coincided with the disappearance of smoke. The heat dissipated in the solid fault was estimated to have a value of 10-40 watts. Shortly thereafter, a jagged arcing voltage was again observed on the oscilloscope with an associated development of more burning and smoke.



Fig. 7. Simulated ground-fault test, resulting in smoke.

This escalation and de-escalation pattern repeated itself erratically with an average time cycle of about one minute. The test was terminated after 16 minutes after which the insulation between turns was measured at only 10 ohms. The resultant burning damage is shown in Fig. 8. The low turn insulation value further suggests that in the presence of a magnetic flux, a turn-to-turn short circuit could have resulted.

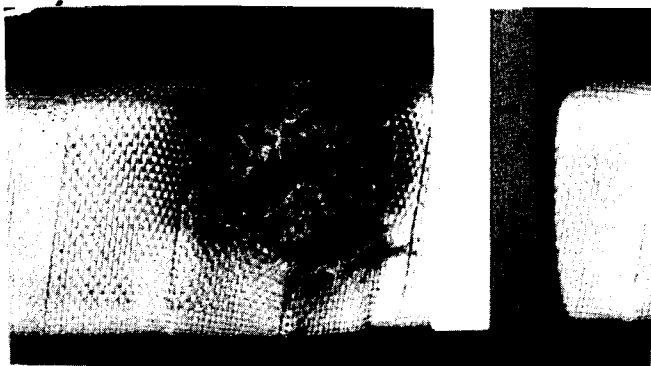

Fig. 8. Resulting burning damage due to simulated 3A, 16 minute ground-fault test.

Recognizing the shortcomings in the simulation tests, it can be concluded that a motor ground fault in the arcing stage releases considerable heat energy, causing significant damage. Once escalation to a solid ground fault occurs, the heat energy is considerably reduced. The erratic pattern of escalation and de-escalation defies any prediction as to the ultimate damage, should the fault be allowed to persist for an indeterminate length of time. The hazard of coil-to-coil failures and iron-core damage can therefore not be ruled out.

Reflecting on these observations, it appears that motor-winding ground faults in a high-resistance grounded system need to be expediently located and removed.

A limited survey on the fault-locating and removal time of 2.4 and 4.16-kV high-resistance grounded systems reveals that:

- . some users trip on the first indication of a ground fault, which of course, requires selective ground-fault relaying in the presence of small (up to 8A) ground faults. Available hardware limitations complicate the general application of this approach.
- . some users alarm only. If the fault is located in a nonessential circuit, fault removal can be accomplished in two to ten hours, depending on the time of alarm and the availability of electricians. If, however, the fault is located in an essential circuit which cannot be de-energized, the fault duration extends to possibly several days, with the attendant higher risk of fault escalation.

To put hi-R grounding of low-voltage systems in the proper perspective, it should be noted that with the considerably lower fault energies released, the hazard of fault escalation is proportionately decreased.

Ground-fault Relay Sensitivity Limitations

Due to the small ground-fault currents allowed to flow in a hi-R grounded system, the development of very sensitive ground-fault relays has been urged by some advocates and practitioners of hi-R grounded systems. The need has been justified on the basis that these relays can serve as a monitor of insulation system dielectric strength. The underlying philosophy is that a ground fault gradually "grows" in current value to a level where fault detectors can operate before a significant further increase in ground-fault current occurs. Another viewpoint is that incipient faults have initial current values in milliamperes. With time, the fault current increases only slightly until a breakdown point is reached in the insulation. Then the current in the ground fault increases significantly almost instantaneously.

These considerations have led to the application of very sensitive (less than one ampere) ground-fault protectors on motors. These protectors, however, are likely to operate falsely for two reasons.

First, for an external ground fault, the detector will sense the proportional contribution of the downstream equipment to the total system capacitive current ($3I_{CO}$) flowing in the ground fault (Fig. 4). Medium-voltage motors alone may have charging currents around 0.1 amperes or less. However, at 4.16 kV, the

surge capacitor adds a significant 1.35 amperes (total). Hence, a sensitivity of less than 1.5 amperes should be avoided on motor circuits with surge capacitors.

The second cause of false operation originates from the use of window-type current transformers. The well-known effects of local saturation due to the physical positioning of cables within the CT is likely to produce a relatively small relay current when the circuit experiences a downstream multiphase through fault (no involvement of ground). A test of this situation using a 12 in. type JCG-0 50/5 CT and a PJC relay set at 0.5 amperes showed that the relay consistently tripped for a 25,000 amperes through-fault. With a primary theoretical ground-fault sensitivity of 5 amperes, it can be concluded that the relay sensed 0.02 per cent of a multiphase through-fault. Further tests showed that by proper centering and bracing of conductors the error could be reduced to 0.01 per cent, thus requiring 50,000 amperes of through-fault current to cause false tripping.

The probable causes of false operation can, of course, be reduced by a slight time delay in the relay response time, long enough for the appropriate interrupter to remove the fault.

High- or Low-resistance Grounding at 13.8 kV?

As indicated previously, the alarm-only hi-R grounded 13.8 kV has proved to be unsuccessful. As a consequence, all known applications are of the hybrid type and arranged to trip on a fault indication, thereby losing the desired operational feature of preventing unscheduled shutdowns.

These hybrid 13.8-kV hi-R grounded systems now require ground-fault responsive trips to help assure ground-fault selectivity. Attempts to use presently available and economical ground-fault protective devices with their inherent sensitivity of about 15 amperes, necessitated an increase in the magnitude of ground-fault currents to three to four times the system charging current (60A-80A).

Upon reflection, it becomes apparent that this grounding mode should not be classified as a hi-R grounded system. In fact the features of this mode of grounding are characteristic of low-R grounded systems. Low-R grounding at 13.8 kV has generally been implemented at 400 amperes, but a closer analysis would make 200 amperes feasible, depending upon the specific system layout and ground-fault protection requirements. The unique motor-transformer unit application could be adequately protected by 50 amperes low-R grounding.

The contention that in general 60 amperes should be better than 400 amperes is quite debatable for these reasons:

- . From a *burning-damage* point of view, extensive experience with 400 ampere grounding has proven that burning damage is minor. While the burning damage at 60 amperes will usually be less (assuming same fault-clearing time), the net result is no different. The faulted cable section needs to be replaced and the faulted motor or transformer *core* is not damaged.
- . From a *machine winding ground-fault protection* point of view, the generally accepted philosophy

is based on protecting 90% of a wye-connected winding. The probability of a ground fault in the last 10% towards the neutral is small since the ground insulation is stressed by only 10% of the normal line-to-neutral voltage, which is 8000 volts on a 13,800-volt system. Given the generally available instantaneous ground-sensor sensitivity of 15 amperes, it can be deduced that at least a 150-ampere grounding resistor should be used. A 60-amp grounded system leaves an unprotected zone of $(15/60) \times 100 = 25\%$, while in a 400-amp grounded system, this zone is only $(15/400) \times 100 = 3.75\%$.

- From a generator-differential protection point of view, a 60-ampere ground fault in a generator is generally below the sensitivity of generator differential relays. Depending upon the phase CT ratios and loading, generator differential relays pick up at 60 to 200 amperes. A 400-amp resistor will protect 85% to 50%, respectively, of a generator winding. It could be argued that the CT and relay in the generator neutral can be set more sensitively. This argument holds only if there is just one grounding resistor in the zero-sequence circuit and ignores the fact that the resistor CT and relay should provide only back-up or calamity protection.
- From a bus-differential protection point of view, the 60-ampere grounded system is equally deficient for the reason that bus-differential relays typically have sensitivities varying between 75 and 200 amperes.
- From a transformer-differential protection point of view, the relay sensitivities, as influenced by winding connections and voltage ratios, are generally well above 800 amperes on delta-wye connected industrial transformers. Special protection is therefore usually provided to help assure that adequate ground-fault protection is secured.

It can be concluded that a 13.8 kV, the hi-R grounding mode, arranged to trip is inferior to the conventional low-resistance grounded system where the resistance is appropriately selected to maximize ground-fault protection of all system components. The hi-R grounded system, arranged to alarm, should not be considered.

High-resistance Grounding at 2.4 kV and 4.16 kV

The previous text supports the acceptance of alarmed hi-R grounding on these voltage levels with one qualification. The system charging current ($3I_{CO}$) should not exceed 5.5 amperes for a maximum of ground fault of 8 amperes. At the maximum level, fault escalation is more likely, but based on operating experience, it can usually be avoided if the fault is expeditiously located and removed. If the fault is in a motor winding, escalation to or further deterioration of a turn-to-turn insulation breakdown cannot be ruled out. The consequent shorted-turn currents of many times rated current can considerably increase burning damage of the adjacent windings and core slots.

High-resistance Grounding at 480 Volts and 600 Volts

Hi-R grounding has been most successful in low-

voltage systems provided the following limitations are observed:

- It is applicable only to three-phase, three-wire systems. The exclusion of three-phase, four-wire (such as 480 wye/277 volt) systems will become evident by the following review:

As shown in Fig. 9A, a low-voltage transformer winding may not only serve a three-phase load, but also a phase-to-phase load, or phase-to-neutral load (L). It should be recognized that neither a three-phase load nor a phase-to-phase load current (not shown) results in a neutral conductor current. Only a line-to-neutral load will force a 60-Hz current in the neutral conductor.

Since under balanced operation no current flows from the neutral to ground, the neutral potential (relative to ground) will be zero. Such a system could operate satisfactorily if it were not for the fact that a line-to-ground fault or a neutral-to-ground fault will adversely affect the safe operation of this system.

In Fig. 9A, a line-to-ground fault is assumed on phase "a". Further assuming that the neutral resistor is 277 ohms, the ground-resistor current will be one ampere. Note that the voltage across the resistor will rise to 277 volts, which forces the neutral to operate at 277 volts above ground. The "b" and "c" phase conductors now operate at 480 volts to ground. Article 210-6 of the National Electrical Code limits the voltage to ground of lighting fixtures to 300 volts. Thus 480Y/277-volt systems, serving line-to-neutral lighting loads, must be operated with solidly-grounded neutrals. Small amounts of 277V lighting can be accommodated on hi-R grounded systems by the use of 480V delta-480V wye-connected transformers.

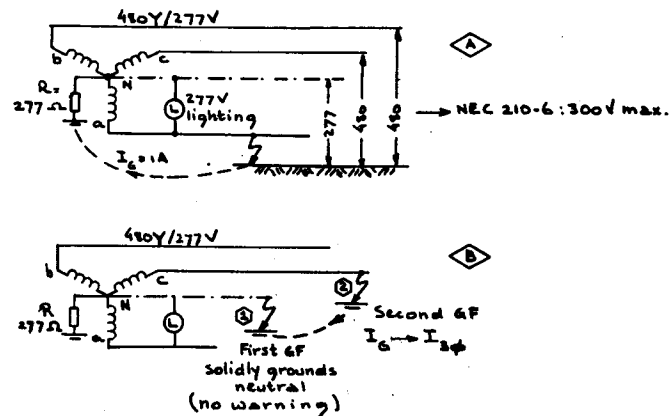

Fig. 9. Illustration showing why three-phase, four-wire (480 wye/277V) systems cannot be resistance grounded.

Another unsatisfactory operating condition will be created when a neutral conductor is accidentally grounded (Fig. 9B). Such a connection will short circuit the neutral resistor and essentially convert the system to a solidly-grounded neutral system as long as this fault condition remains unnoticed. While sensing of this

condition is virtually impossible, the occurrence of a second phase-to-ground fault will cause a large ground-fault current to flow external to the neutral resistor.

- Rectifier or SCR loads *without* isolation transformers should be avoided unless the hi-R grounding package properly responds to ground faults on a d-c bus as explained under the next heading.

Hi-R neutral grounding has been successfully applied to convert existing solidly-grounded low-voltage systems which lack arcing ground-fault protection. The installation of a pulsing hi-R neutral grounding package is more economical and easier to install as compared to additional ground responsive devices on main secondary breakers and/or feeder breakers.

The ease with which an existing delta ungrounded system can be converted to hi-R grounding, to gain the benefits of a neutral grounded system, provides another opportunity for the application of hi-R grounded systems.

The Effect of Voltage Conversion Equipment on Hi-R Grounding

The gaining popularity of conversion equipment to derive a constant or variable d-c voltage introduces an obscure effect on the hi-R grounding equipments if no isolation transformer is used to separate the zero-sequence circuit of the a-c system from the normally ungrounded d-c system.

In the presence of a delta-wye isolation transformer, a d-c ground fault will not result in a current flow in the hi-R grounding equipments. The trend away from isolation transformers for economic reasons emphasizes the need for a better understanding of the effect on the hi-R grounding equipments.

First of all, line-to-neutral connected rectifiers cannot be used in hi-R grounded systems, which will not be elaborated on due to their very infrequent application. Instead, the phase-to-phase connected rectifiers will be emphasized.

To develop an understanding of the problem, the fundamental circuit components are shown in Fig. 10, showing a constant d-c voltage rectifier bank.

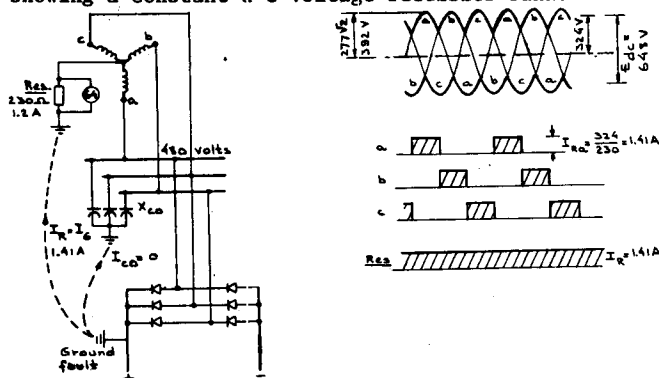

Fig. 10. Rectifier load *without* isolation transformer produces d-c fault currents when either polarity becomes grounded.

A ground fault on the positive d-c bus will cause only a resistive current to flow. The current through the capacitive reactance $X_{CO}/3$ is, of course, blocked.

The 230-ohm resistor perceives a d-c pulse during each positive and negative cycle of a 60-Hz voltage wave. In the three-phase system, the resistor will therefore pass a d-c pulse through phases a, b and c, sequentially, which causes an average value direct current to flow in the resistor continuously. Given a 227V l-n voltage, the d-c driving voltage averages about 324 volts, which results in a resistor average direct current of $324 + 230 = 1.41$ amperes. The resistor is rated to pass $277 + 230 = 1.2$ amperes. As a first consequence the resistor should have a 16% higher watt or current rating. As a second consequence, the voltage relay (device 64) should be equally responsive to 60-Hz as to d-c voltages to help assure that it will sound an alarm.

It should be noted that rectifiers so applied are generally used on 600V-class systems only. Consequently, the problem should be limited to high-resistance grounded low-voltage systems.

Conclusions

High-resistance grounding is here to stay. It is anticipated that its application will find wider acceptance, particularly on low- (600-volt class) and most medium- (5-kV class) voltage systems serving continuous process plants.

The use of hi-R grounding on 600V systems precludes line-to-neutral loading as in 480-wye/277-volt systems. The presence of rectifier loads without isolation transformers requires ground-fault sensing equipment which responds to both a-c and d-c voltage or current.

The use of hi-R grounding of 5-kV-class systems should be restricted to systems with charging currents of about 5.5 amperes or less, resulting in a ground-fault current of about eight amperes or less. This limit is based on a limited experience record and it should not be inferred that fault escalation will, in fact, not occur.

The use of hi-R grounding of 15-kV-class systems should not be attempted. The modification of tripping a circuit breaker rather than alarming in response to a ground fault is a subterfuge which is generally inferior to using low-resistance grounding at levels between 50 to 800 amperes.

In accepting the hi-R grounding mode, users should be prepared to commit themselves to expeditiously locate and remove the faulted circuit to reduce the probability of fault escalation, multiple shutdowns, and severe equipment damage.

References

- F.K. Fox, H.J. Grots and C.H. Tipton; "High-resistance Grounding of 2400-volt Delta Systems with Ground-fault Alarm and Traceable Signal to Fault"; IEEE Transactions on Industry and General Applications, vol. IGA-1 No. 5, Sept/Oct 1965.
- F.K. Fox and L.B. McClung; "Ground-fault Tests on High-resistance Grounded 13.8-kV Electrical Distribution System of Modern Large Chemical Plant-Part 1"; IEEE Transactions on Industry and General Applications, vol. IA-10 No. 5, Sept/Oct 1974.
- L.B. McClung and B.V. Whittington; "Ground-fault Tests on High-resistance Grounded 13.8-kV Electrical Distribution System of Modern Large Chemical Plant - Part II"; IEEE Transactions on Industry and General Applications, vol. IA-10 No. 5, Sept./Oct 1974.