

Copyright © 2003 IEEE.

Reprinted from IEEE TRANSACTIONS ON INDUSTRY APPLICATIONS, VOL. 37, NO. 4,
JULY/AUGUST 2001, PAGES 1140-1151.

This material is posted here with permission of the IEEE.

Such permission of the IEEE does not in any way imply IEEE endorsement of any products or services of Powell Electrical Manufacturing Company.

Internal or personal use of this material is permitted. However, permission to reprint/republish this material for advertising or promotional purposes or for creating new collective works for resale or redistribution must be obtained from the IEEE by writing to pubs-permissions@ieee.org.

By choosing to view this document, you agree to all provisions of the copyright laws protecting it.

Is Selectivity Achieved in Critical Low-Voltage UPS and Standby Generator Power Circuits?

Roy E. Cossé, Jr., *Senior Member, IEEE*, James E. Bowen, *Member, IEEE*, and William H. Nichols, *Member, IEEE*

Abstract—This paper reviews typical critical low-voltage uninterruptible power supply (UPS) systems and standby generator power circuits used in the petrochemical industry to determine if selectivity is achieved between protective devices during short-circuit conditions. Alternate system configurations are proposed when complete selectivity is not achieved. Generator excitation systems and UPS support during fault conditions is discussed.

Index Terms—Automatic transfer switch, high-resistance grounding, permanent magnetic generator, selectivity, self-excited excitation system, standby generator, uninterruptible power supply.

Key Term—Selectivity of a protection system. This is a general term describing the interrelated performance of relays, circuit breakers, and other protective devices; therefore, complete selectivity is obtained when a minimum amount of equipment is removed from service for isolation of a fault or other abnormality.

I. INTRODUCTION

THE modern business climate requires an evaluation of previous practices so more effective configurations of critical low-voltage uninterruptible power supply (UPS) and standby generator power circuits can be implemented. As part of the evolving knowledge base, today's application engineers must understand basic system design and protective device coordination of these critical process support systems. This paper reviews typical critical system configurations, highlights design concerns for modern backup systems, and considers alternatives for increased system selectivity during short-circuit conditions. Comments concerning UPS and standby generator performance during short-circuit conditions are interlaced in the discussions. The three-phase three-wire distribution system of Fig. 1 is considered a typical critical low-voltage UPS and standby power circuit; it contains contactor-type automatic transfer switch (ATS), standby generator, and UPS system.

Paper PID 00-5, presented at the 1999 IEEE Petroleum and Chemical Industry Technical Conference, San Diego, CA, September 13-15, and approved for publication in the IEEE TRANSACTIONS ON INDUSTRY APPLICATIONS by the Petroleum and Chemical Industry Committee of the IEEE Industry Applications Society. Manuscript submitted for review September 15, 1999 and released for publication May 7, 2001.

R. E. Cossé, Jr., was with Kellogg Brown and Root, Inc., Houston, TX 77002 USA. He is now with Powell Electric Manufacturing Company, Houston, TX 77217 USA (e-mail: rcosse@powl.com).

J. E. Bowen is with Powell Electric Manufacturing Company, Houston, TX 77217 USA (e-mail: jbowen@powl.com).

W. H. Nichols is with Siemens Westinghouse Technical Services, Houston, TX 77040 USA (e-mail: bill.nichols@sea.siemens.com).

Publisher Item Identifier S 0093-9994(01)05900-X.

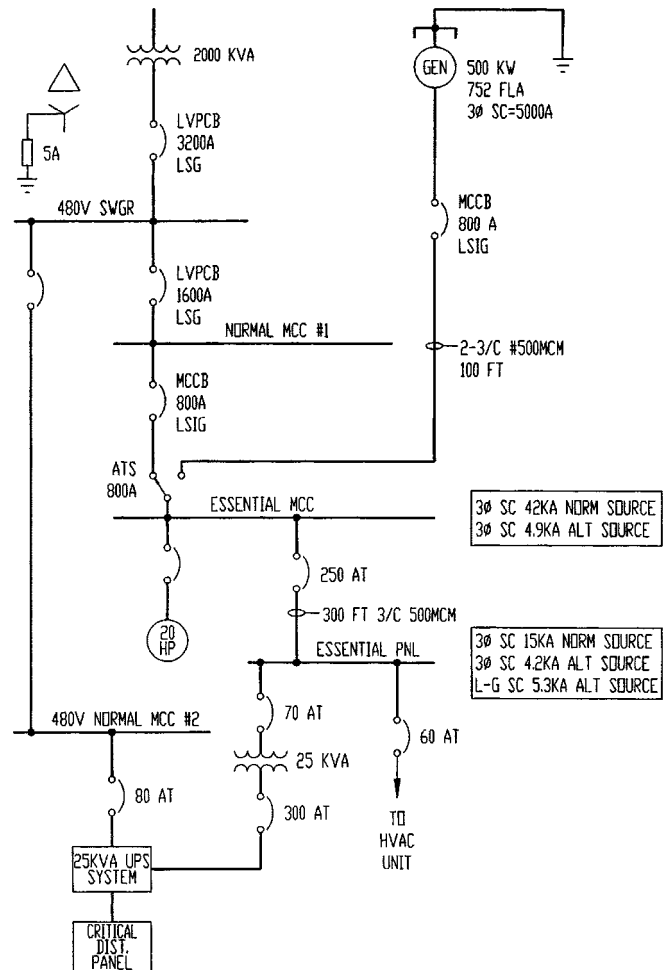

Fig. 1. Typical critical UPS/standby generator system configuration.

(Three-phase four-wire distribution systems are not considered in this paper.)

II. PERMANENT-MAGNET GENERATOR VERSUS SELF-EXCITED EXCITATION SYSTEM

Modern standby generator excitation systems are typically the brushless permanent-magnet generator (PMG) type. A PMG excitation system consists of a PMG, rotating exciter, diode rectifier and main generator field (all mounted on the same common shaft), and a stationary voltage regulator. When a fault occurs on a standby generator system, the generator produces a high fault current level during the first 1-3 cycles (16.7-50 ms). Initially, the short-circuit output current magnitude is

limited by three key parameters: the generator subtransient reactance, the level of excitation prior to the fault, and the faulted system circuit impedance. During a fault, the automatic voltage regulator (AVR) voltage-sensing circuit detects the depressed generator terminal voltage. Utilizing the PMG as a dependable power source, the AVR forces the exciter field dc current to a maximum. The increased exciter field current causes the generator main field to produce higher internal counter electromagnetic force (CEMF), thereby supporting the generator current contribution to the fault for a time period well beyond the subtransient and transient time constants. With sustained generator fault current contribution, the feeder breaker protective relays should detect and clear the fault, thereby maintaining system coordination. Because a phase fault unloads the generator and prime mover, the generator speed tends to increase for a short time, sustaining PMG rotation to power the AVR. This is discussed in Section III.

If the generator excitation is not increased during a fault (no field overexcitation) but maintained at prefault levels, a classical alternating current decrement curve results from the generator subtransient reactance, transient reactance, synchronous reactance, and associated short-circuit time constants. Usually, the final current will be less than generator full-load current. To fully utilize its capability and help maintain system coordination, a PMG-supported generator with the field-forcing capability must be properly specified, and the output voltage of the PMG must be suitable for the required forcing.

If a generator is provided with field overexcitation (field forcing), the exciter field “boost” voltage will increase the generator stator current to 2–3× the generator full-load current typically for 10 s. Increased generator stator current is important to ensure feeder and generator overcurrent protective relays can respond properly to the fault condition.

The manufacturer should submit the current magnitudes and time duration in the form of a generator decrement curve for incorporation into the system studies. When a decrement curve is not available, an “early project” nominal decrement curve can be constructed from the estimated generator subtransient reactance, synchronous reactance, typical industry application data, and engineering common sense. The synchronous reactance is based on manufacturers data, if readily available, or industry handbook data. Generator synchronous reactance is usually in the 1.5–2.0 per-unit reactance range. With 2.0 per-unit synchronous reactance and no field “boost,” the generator output fault current reduces to an estimated 50%–80% of generator full load within approximately 1 s; this makes selective coordination very difficult for multilevel systems.

Utilizing log–log paper, a proposed method of plotting an estimated generator decrement curve utilizes the following three points:

- subtransient reactance at 10 ms;
- transient reactance (based on engineering experience) at approximately 200 ms;
- synchronous reactance at 1000 ms.

The next step is to approximate a smooth curve, joining the three plotted points. Once this estimated decrement curve is constructed, observation may indicate that some protective devices

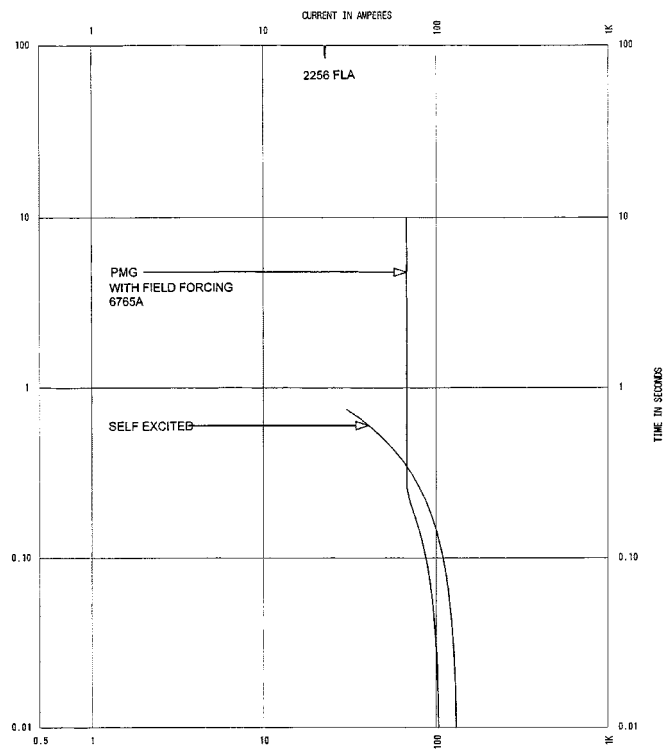

Fig. 2. Generator three-phase decrement comparison example PMG and self-excited brushless excitation systems. Current scale $\times 100$. Reference voltage 480 V.

are unable to detect the decaying fault current. With this information available to the application engineer, system limitations can be determined and suitable alternatives implemented early in the project. If a generator with field boost is specified, the estimated decrement curve should be modified to include a vertical line from 500 ms to 10 s with an assumed magnitude of 3× full-load current. Obviously, the proposed “early project” decrement curve must be replaced with final manufacturing data.

A major difference between the PMG and self-excited excitation support systems is the self-excited type does not have a reliable power source that can power the AVR during a system fault. In the event of a three-phase fault combined with a self-excited excitation system, the AVR-sensing potential transformer (PT) experiences a significantly reduced bus voltage caused by the fault. However, the AVR without “boost” does not receive the necessary external power input to provide the sustained exciter field overvoltage and cause generator increased output contribution current to the fault. Consequently, the exciter field voltage collapses and the generator output current decays rapidly.

Fig. 2 shows decrement curve examples of both the PMG with field forcing and a self-excited (“nonboost”) type field excitation system. The two generators have the same kilowatt and power factor rating, however, the subtransient reactance of the PMG-type generator is often greater than the subtransient reactance of the self-excited generator. This attempts to provide a self-excited generator that will trip instantaneous protective relays before the decrement curve decays excessively. The PMG-type system is able to provide longer sustained generator output current; whereas the self-excited system provides only

TABLE I
APPROXIMATE SHORT-CIRCUIT CURRENT FOR REMOTE THREE-PHASE FAULTS WITH A 480-VOLT 42-kA SOURCE USING 3/C 75 °C
COPPER CABLE IN A NONMAGNETIC DUCT. DISTANCE IS ONE WAY IN FEET

Cable	Ohm/1000FT R	Ohm/1000FT X	100 ft	200 ft	300 ft	400 ft	500 ft	600 ft	700 ft
#12	2		1385	693	462	346	277	231	198
#10	1.3		2129	1066	711	533	426	355	305
#8	0.811	0.0503	3382	1700	1135	851	681	568	487
#6	0.51	0.0457	5308	2685	1796	1348	1080	900	772
#4	0.321	0.0422	8179	4203	2822	2123	1702	1420	1218
#2	0.202	0.039	12167	6460	4377	3307	2656	2220	1906
2/0	0.101	0.0355	19332	11348	7946	6097	4942	4153	3581
4/0	0.0633	0.0332	23510	15114	10992	8605	7060	5981	5186
250	0.0541	0.033	24519	16220	11965	9443	7788	6621	5757
350	0.0368	0.0328	26230	18354	13981	11253	9403	8070	7065
500	0.0276	0.0311	27391	19824	15418	12580	10611	9169	8070
750	0.0197	0.0297	28296	21047	16675	13780	11730	10207	9031

initial short-circuit current, and the generator output fault contribution current decays rapidly.

Because the self-excited generator supplies maximum fault current for a very short time, it is often difficult to maintain selectivity between time-overcurrent devices for downstream faults. If the fault is not interrupted by the downstream protective device during the first few cycles, the fault may not be properly detected; even though several levels of short-circuit protection are available throughout the standby distribution system.

When standby generators supply limited short-circuit current, definite time characteristic relays may provide better selectivity because the tripping time is constant throughout the pickup range. Because inverse-time-overcurrent relays typically integrate effective fault current versus time, generator decrement curves make predicting tripping time difficult. Low-voltage solid-state trip units typically are provided with instantaneous and long-time protection elements. Usually, the long-time pickup has an inverse characteristic. However, when short-time delay elements are specified, a definite time characteristic is provided for the short-time delay function. The advantage of the definite time characteristic is the complex method of determining the device tripping time in [5] is not required, which simplifies the application for engineering and operations.

III. MODERN STANDBY GENERATOR ISOCHRONOUS GOVERNOR SYSTEM RESPONSE

At the instant a bolted three-phase fault occurs, generator real power (kilowatt) does not flow beyond the fault point. Consequently, the generator driver suddenly experiences an abrupt load rejection. If the generator driver was operating at full load, it would attempt to change from full-load power output to no-load power output. Actually, the generator driver increases speed since the fuel valve cannot instantaneously change position. In response to sustained short-circuit transients, the modern prime mover's fast-acting governor and fuel control system must respond quickly to prevent a driver overspeed trip during the brief time of load rejection. This is a significant concern of any standby generator system.

Consequently, the governor control system response should be thoroughly evaluated during factory testing and field startup to confirm that the generator driver response is capable of enduring a fault condition without an adverse driver trip.

IV. LOW-VOLTAGE CABLE AND SHORT-CIRCUIT CURRENT MAGNITUDES

Low-voltage cable adds significant impedance to the system relative to the low magnitude of driving voltage. Hence, even relatively short cable lengths result in considerable fault current reduction. Tables I and II show the effect 480-V Essential Motor Control Center (MCC) feeder circuit cables have on fault magnitudes. Table I provides results for the normal system configuration with the 2000-kVA transformer supplying 42-kA three-phase fault current to the 480-V Essential MCC bus. Table II provides results for the standby system configuration with the 500-kW standby generator providing an initial 5-kA three-phase fault current to the 480-V Essential MCC bus. With the same cable length, as the cable size increases the impedance is less dominant in restricting short-circuit current flow. As an example, Table I shows 300 ft of 3/C#10 cable reducing the fault magnitude from 42 000 to 711 A; whereas, using 300 ft of 3/C#500 kcmil cable reduces the fault magnitude from 42 000 to 15 418 A.

As the example shows, to insure selectivity, a detailed review of fault levels and protective devices is needed when system design requires circuit breakers or fuses remotely located from the switchgear or MCC building. This includes applications such as outdoor lighting panels, skid-supplied power panels, or other remote interrupting devices. For a remote fault, there is the possibility of insufficient fault current for remote circuit breaker or fuse instantaneous detection and prolonged voltage collapse at the remote panel will shutdown critical instrument loads. The following example is reviewed to illustrate this concept. In Fig. 1, the 100 ft of 500 MCM cable between the standby generator and the 480-V Essential MCC does not have a significant impact on the available fault current. However, an assumed load 300 ft from the 480-V Essential MCC is protected by a 20-A circuit breaker mounted at the load. A

TABLE II
APPROXIMATE SHORT-CIRCUIT CURRENT FOR REMOTE THREE-PHASE FAULTS WITH A 480-VOLT 5-kA SOURCE USING 3/C 75 °C COPPER CABLE IN A NONMAGNETIC DUCT. DISTANCE IS ONE WAY IN FEET

Cable	Ohm/1000FT R	Ohm/1000FT X	100 ft	200 ft	300 ft	400 ft	500 ft	600 ft	700 ft
#12	2		1336	686	460	346	277	231	198
#10	1.3		1962	1043	704	530	425	354	304
#8	0.811	0.0503	2742	1585	1094	832	670	561	482
#6	0.51	0.0457	3524	2297	1651	1278	1039	874	754
#4	0.321	0.0422	4098	3063	2351	1881	1559	1327	1154
#2	0.202	0.039	4431	3699	3068	2578	2205	1918	1692
2/0	0.101	0.0355	4642	4226	3819	3448	3121	2837	2593
4/0	0.0633	0.0332	4701	4384	4078	3791	3528	3289	3073
250	0.0541	0.033	4710	4411	4125	3858	3612	3388	3183
350	0.0368	0.0328	4722	4449	4195	3960	3744	3546	3364
500	0.0276	0.0311	4740	4487	4254	4038	3840	3657	3488
750	0.0197	0.0297	4754	4516	4298	4097	3912	3742	3584

3/C #10 cable is used to accommodate the load ampacity and voltage drop requirements. Table I shows a three-phase fault at the load results in 711-A fault current. This is adequate to trip the 200-A instantaneous element of the local 20-A circuit breaker. However, in a more practical case, if a nonbolted fault occurs, the fault magnitude may be less than 200 A due to the arc resistance, and the local circuit breaker may not instantaneously interrupt the fault flow.

Not only does cable impedance have significant fault limiting effect, but the impedance of an arcing fault and the associated voltage drop (arc voltage) can be significant when compared to the system driving voltage. This makes predicting system response during a fault even more difficult. Proper system coordination assures selectivity so predictable protective device performance is achieved during reduced fault current. If cable lengths are very long and fault current is reduced to a magnitude that downstream protective devices cannot detect, then the application engineer must identify areas of nonselectivity for further evaluation. For low-voltage applications, the application engineer must determine a practical sensitivity ratio of available fault current divided by instantaneous trip value pickup. This is achieved by keeping the load circuit protection rating small when compared to the available fault current.

V. STANDBY GENERATOR SYSTEM CONSIDERATIONS

Fig. 3 shows the protective device coordination of the typical 480-V system Fig. 1 with a standby generator that cannot be exposed to overload. An 800-A ATS with a 3-cycle 50-kA rms withstand rating is selected for this example to match the 500-kW generator continuous current rating (752 A) and the 42-kA short-circuit capability of the normal source power system. Even if a smaller 200-kW standby generator is supplied, an 800-A ATS is required to accommodate the normal source 42-kA rms symmetrical available short-circuit current. The Essential MCC feeder breaker 800-A 100% rated molded case circuit breaker (MCCB) protects the 3-cycle 50-kA rms SYM ATS rating because the instantaneous element interrupts faults within the ATS short-circuit withstand time. Therefore,

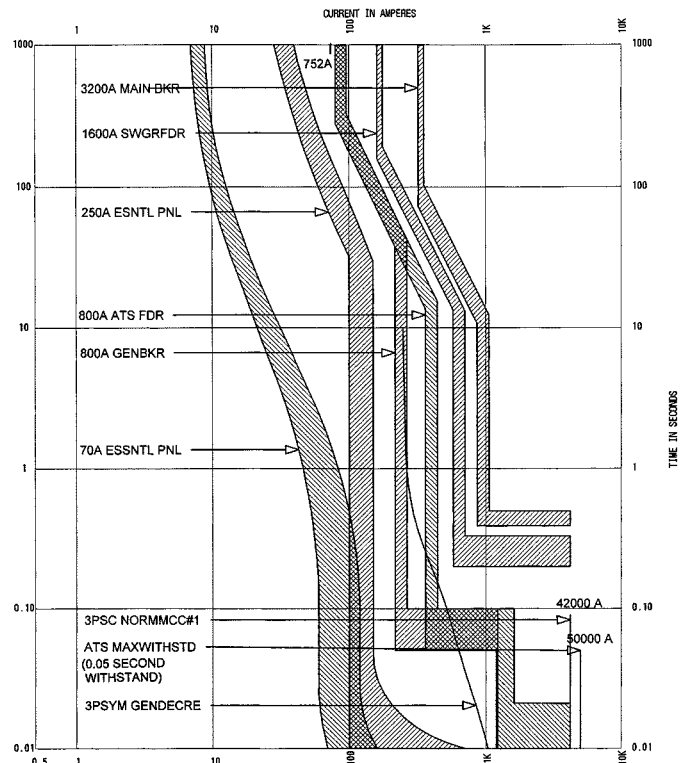

Fig. 3. Standby generator system configuration phase protection. Current scale $\times 10$. Reference voltage 480 V.

the ATS short-circuit withstand rating is adequate for the 800-A feeder breaker instantaneous trip critical clearing time. System X/R ratio must be reviewed with respect to equipment interrupting and withstand ratings.

Examining the backup protection of the 3200-A main breaker and the 1600-A switchgear feeder breaker, notice the high magnitude fault region. Time delay is added to upstream devices to provide selectivity with the Essential MCC 800-A ATS feeder breaker. The 800-A ATS feeder breaker instantaneous element offers adequate protection for high magnitude faults, however, there is no ATS backup protection within the short-circuit withstand of the ATS.

If the standby generator is supplying power to the system, Fig. 3 shows the generator 800-A 100% rated MCCB instantaneous element set near minimum to sense and clear a fault at the Essential MCC bus. The maximum available initial fault current from the standby generator with PMG response is approximately 8 kA compared to 42 kA from the 2000-kVA transformer. Fig. 3 shows the Essential Panel 250-A MCCB feeder breaker instantaneous element will clear a load-side high-magnitude bolted phase fault, but a high-impedance fault on the Essential MCC bus may appear as an overload. This fault type would have to be cleared by the thermal portion of the breaker trip element with the help of the PMG/AVR forcing function. This “near miss” condition could result in a very long breaker thermal element clearing time coupled with significantly depressed bus voltage, resulting in a disruption to the plant process. To prevent physical damage and process upsets associated with this high-impedance uncleared fault, additional considerations should be taken to minimize the possibility of phase-to-phase faults in the downstream MCC. This can be accomplished by specifying additional insulation via the insulated equipment bus, phase barriers, insulating “boots” and tape in the Essential MCC and all applicable downstream load equipment.

Another observation is the lack of selectivity between the Essential MCC 250-A feeder breaker and the Essential Panel 70-A feeder breaker. If possible, the Essential Panel should be eliminated and the loads relocated to the Essential MCC. This eliminates cascaded MCCBs with poor flexibility for providing system selectivity and multiple series breaker trips. When the Essential MCC 250-A feeder breaker trips on a fault that should be cleared by a downstream MCCB, the Essential Panel is shut-down.

VI. GROUND-FAULT PROTECTION

Standby generators are commonly installed with solidly grounded neutrals. The standby generator manufacturer must confirm the generator is braced for line-to-ground short-circuit conditions to maintain machine stresses within generator design limits, since it is not a NEMA requirement to design neutral grounded generators to tolerate the extra stresses caused by phase-to-ground faults. Generally, standby generators have a 2/3 winding pitch factor so the generator does not produce third harmonic circulating currents. In examining the symmetrical component model of a solidly grounded generator, ground-fault magnitudes can be significantly greater than generator three-phase fault currents because the generator zero-sequence reactance is less than the positive- and negative-sequence reactances for a 2/3 pitch factor machine.

The generator ground fault decrement curve of Fig. 4 is provided to show the generator response to a ground fault at the Essential Panel. Often low magnitude ground faults cannot be detected by the MCCB with only phase overcurrent elements. Note that the generator ground-fault trip will often be selective in time but not in pickup current.

One proposed solution is to add a ground-fault system (zero-sequence current transformer and 51 G module) on all downstream breakers to assure selectivity for ground-fault magni-

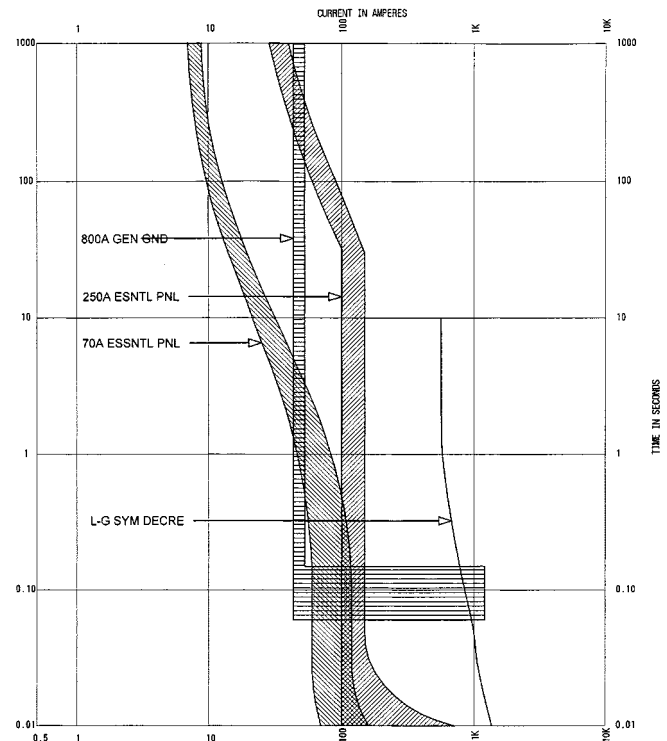

Fig. 4. Standby generator system configuration ground protection. Current scale $\times 10$. Reference voltage 480 V.

tudes above 15 A. (To avoid inhibiting a trip during a reduced voltage caused by a line-to-ground fault, an MCCB dc shunt trip connected to a battery supply should be considered for tripping security. A low-energy ac shunt trip specifically designed for the application may also be considered as an alternate.)

A 51 G relay and current transformer can then be provided in the generator solidly grounded neutral circuit for increased sensitivity and selectivity to low-magnitude (impedance limited) line-to-ground faults, including generator internal winding ground fault detection. By using this approach, ground faults are promptly cleared, critical system voltage is quickly restored, and ground faults are not allowed to escalate to more severe phase-to-ground-to-phase faults. These are important considerations when evaluating various alternative designs and the consequences of losing power to critical process loads.

VII. HIGH-RESISTANCE GROUNDING OF STANDBY GENERATORS

An alternate proposal for enhanced system continuity may be to install a high-resistance grounded system on the generator and limit the ground-fault current to approximately 3–5 A. (Refer to [13] for grounding resistor sizing.) High-resistance grounding offers the advantage of not tripping for the initial ground fault and maintains all phase-to-phase voltages so that critical phase-to-phase connected process loads do not experience a supply interruption. Implementation of generator high-resistance grounding only produces alarms during the initial ground fault, allowing the process to continue while a qualified technician finds the fault using appropriate methods for measuring zero-sequence current on each circuit.

A high-resistance grounded standby generator should be evaluated for both a high-resistance grounded normal source and a solidly grounded normal source.

Care should be taken in applying a high-resistance grounded system, because line-to-neutral loads cannot be served without a solidly grounded neutral bus bar per National Electrical Code (NEC) requirements. If line-to-neutral loads are required, an isolation transformer is needed for the individual load. The transformer should have a phase-to-phase primary and phase-to-neutral secondary with the neutral grounded.

For personnel safety purposes, plant electricians must be thoroughly trained in high-resistance grounding system philosophy and pragmatic implementation. If they do not understand this scheme thoroughly, high-resistance grounding should not be used. (Although a three-phase three-wire system is used for the discussions of this paper, the NEC requires solid grounding of all four-wire systems.)

VIII. ATS SHORT-CIRCUIT WITHSTAND RATING

ATS short-circuit withstand current rating is based on a 1.5- or 3-cycle time duration in accordance with UL 1008. With a 3-cycle time period to interrupt a downstream fault, instantaneous elements are needed on both downstream and upstream MCCBs and low-voltage power circuit breakers (LVPCBs). When LVPCB instantaneous elements are used, the application engineer must confirm the circuit breaker total clearing time including static trip device “wake-up” time. With no load or minimal load on the Essential MCC, the maximum clearing time of the LVPCB static trip device instantaneous element may exceed the 3-cycle total clearing time because of internal electronic self-checking routines, i.e., “wake-up” time. LVPCBs requiring as long as 3 cycles total clearing time are not suitable to protect a 1.5-cycle ATS withstand rating.

Recently, some manufacturers have started the production of 30-cycle ATS short-circuit withstand ratings for the larger units, however, an additional cost is associated with the longer withstand time rating. The extended withstand time rating allows LVPCBs to be applied without the previously needed instantaneous element. Selectivity can be achieved between downstream MCCBs with instantaneous elements and upstream LVPCBs with intentional short-time delay and no instantaneous element, however, the 30-cycle withstand rating must not be exceeded.

To assure proper ATS application, it is important to compare the system available short-circuit current with the ATS short-circuit withstand rating, and to thoroughly review the device coordination of downstream and upstream circuit breakers. Selectivity is a significant concern when evaluating whether the added cost of the 30-cycle ATS is justified for critical standby system applications. This determination can only be made by a complete evaluation of the process system operation and the adverse effects to critical process loads during and after a fault condition.

IX. ATS PROTECTED BY SWITCHGEAR LVPCB WITH CURRENT-LIMITING FUSES

In Fig. 5, the Normal MCC ATS MCCB of Fig. 1 is changed to an LVPCB with current-limiting fuses located at the 480-V

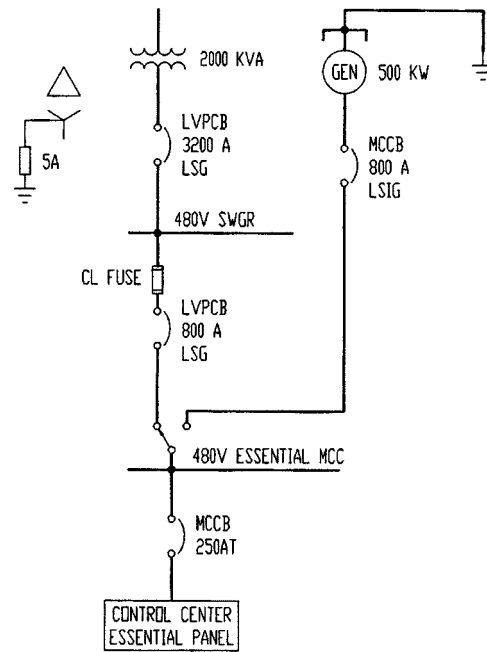

Fig. 5. Standby generator system configuration with LVPCB CL fuse.

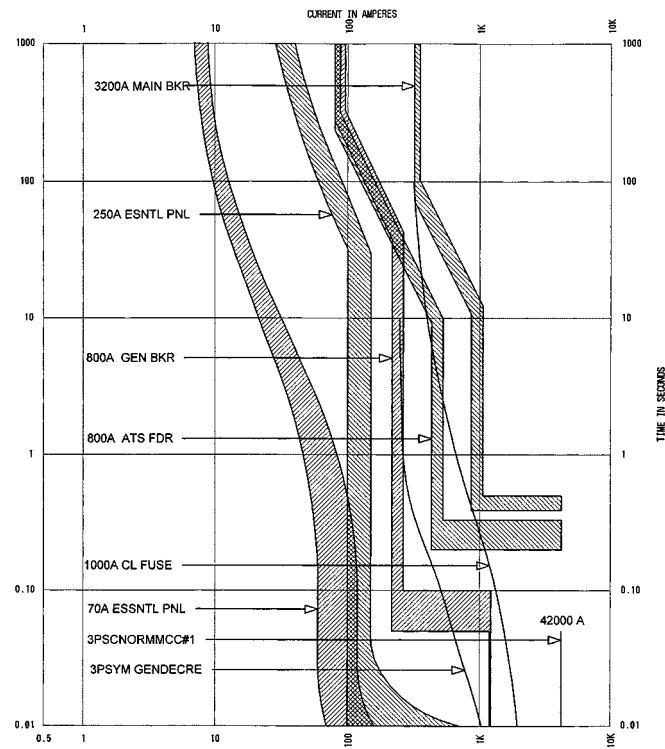

Fig. 6. Standby generator system configuration with LVPCB and CL fuses phase protection. Current scale $\times 10$. Reference voltage 480 V.

Switchgear. The UL ATS/current-limiting fuse rating has a higher combined short-circuit withstand rating than a LVPCB without a current-limiting fuse. Fig. 6 shows the ATS protected by the current-limiting fuse throughout the instantaneous region from 0 to 3 cycles (0–50 ms) while the LVPCB solid-state trip device protection is delayed beyond the 3-cycle ATS rating.

When the standby generator supplies fault current, the generator MCCB may require more than 3 cycles to interrupt the

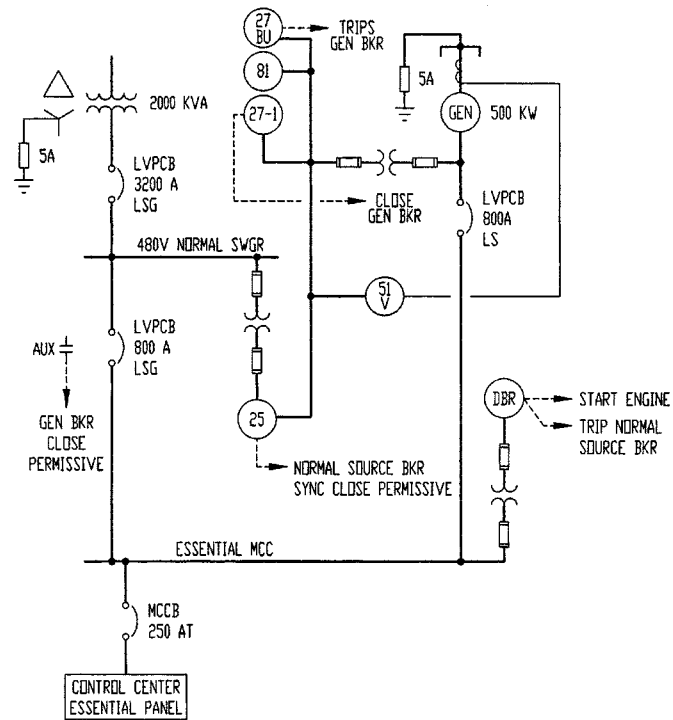

Fig. 7. Alternate standby generator system configuration without ATS and with high-impedance grounding. Additional generator protection relays are required.

fault flow because the generator short-circuit current may be below the generator MCCB instantaneous pickup, thereby requiring the MCCB delayed characteristic to trip. Without an ATS I^2t damage curve [1] or a short-time short-circuit rating that can be extrapolated to various time-current withstand capabilities, there is a significant concern when low-magnitude fault currents exceed the 1.5- or 3-cycle ATS rating. Unfortunately, to the authors' knowledge, ATS manufacturers do not provide "type test" data for this consideration, and data is not readily available without a special factory test at the owners expense. Generally, this is not a concern (with adequate fault current) because downstream MCCBs interrupt downstream faults within the ATS withstand rating. The concern exists when faults are upstream of the Essential Panel MCCBs, on the Essential Panel bus or on the cable between the ATS and the Essential Panel bus.

ATS manufacturers are generally not required to certify a "Close and Latch" capability for UL-rated equipment. As a precaution, protective relaying and additional time delay in the ATS control system should be considered to prevent the ATS from closing the alternate source into a downstream, uncleared fault. One blocking method may consist of the 480-V Switchgear 800-A LVPCB providing a fault trip auxiliary contact to the ATS transfer control logic to inhibit transfer into a fault. If the LVPCB in combination with the solid-state trip unit is not capable of providing the required transfer blocking logic, then additional protective relays will be needed.

X. NON-ATS ALTERNATIVE

Fig. 7 shows an alternative for automatically transferring to the standby generator without an ATS. One advantage is the

1.5- or 3-cycle ATS short-circuit withstand requirement is eliminated as a design limitation on system short-circuit response. This means the upstream ATS feeder circuit breaker is not required to have an instantaneous element, therefore, complete selectivity with downstream devices can be achieved. Also, the concern of not having an ATS I^2t damage curve, during reduced short-circuit magnitudes and delayed breaker tripping times, is eliminated.

Operational aspects of the proposed alternate scheme are straightforward. Upon loss of normal source voltage, the undervoltage "dead bus" relay (DBR) senses a very low bus voltage, issues a generator engine start command, and simultaneously sends a trip signal to the normal source 800-A LVPCB. When the generator is operating above 90% voltage, the undervoltage 27-1 relay sends a permissive close signal to the generator breaker. If an auxiliary contact interlock from the normal source circuit breaker indicates an open breaker, the generator breaker is permitted to close, supplying power to the Essential MCC loads. After the normal source returns and stabilizes, the operator can manually synchronize to the normal source. A sync check (25) relay with adjustable time delay is included to prevent unacceptable out of phase reclosing. After synchronizing, continuous parallel operation can be prevented; the standby generator circuit breaker can be automatically tripped by a normal source LVPCB auxiliary contact interlock. With the generator circuit breaker open, the diesel engine is allowed to operate in a "hot standby" mode for a short time, ready to power loads should the normal source again suddenly become unavailable. Finally, the diesel engine is allowed to operate in a "cool down" mode before stopping.

The alternate standby generator system configuration does not include an ATS with startup and maintenance requirements, and does not require an instantaneous element on the ATS upstream feeder circuit breaker. Hence, complete selectivity of the critical power circuit is achievable. From an operational perspective, there is operator consistency because ATS retransfer to the normal source is typically performed manually, and generator synchronizing and retransfer are performed manually.

If the operating philosophy allows alternate source/normal source synchronizing for brief or long time periods, generator load exercising (without an external load bank) and peak shaving of the utility demand could be performed. However, proper modifications to system design are required such as generator 32, 27, 59, 55, etc., relays. When considering generator parallel operation with another source, evaluate a generator 2/3 winding pitch factor in the stator core because it minimizes the opportunity for third harmonic nuisance circulating currents.

XI. STANDBY GENERATOR PROPOSED 51-V RELAY

As previously discussed, when a three-phase system fault occurs on the Fig. 5 system, the system voltage collapses and the generator terminal voltage is typically reduced to minimum magnitudes. The result is an initial high fault current, followed by a PMG excitation support system supplying sustained (10 s) fault current between $2-3\times$ generator full-load current. If standard MCCBs are used, the generator initial fault contribution current may trip the downstream MCC 250-A MCCB instanta-

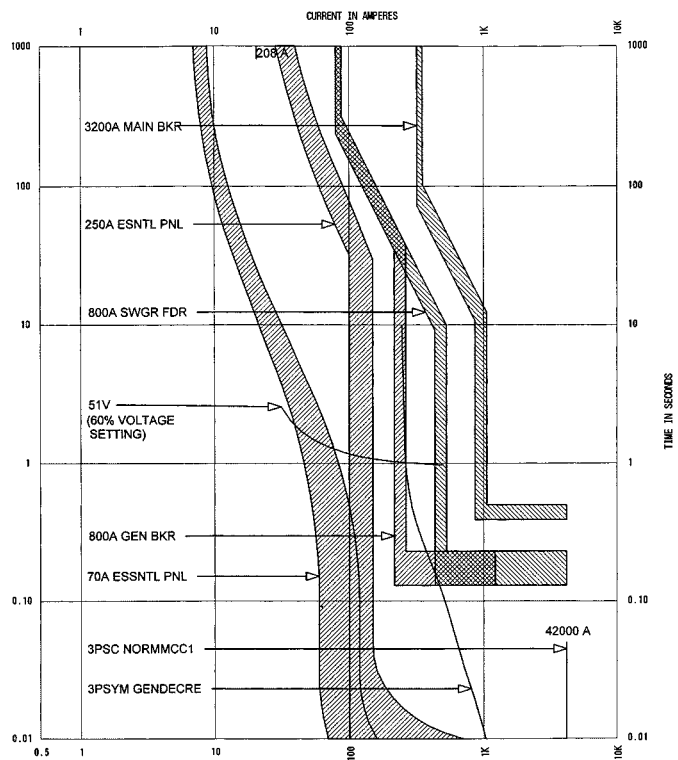

Fig. 8. Alternate standby generator system configuration phase protection. Current scale $\times 10$. Reference voltage 480 V.

neous element and also trip the generator 800-A MCCB instantaneous element.

In Fig. 8, if a generator LVPCB is used with a solid-state trip unit and no instantaneous element, the LVPCB short-time pickup minimum setting may be greater than the decremting fault current depending on the magnitude of fault current. Consequently, the short-time pickup may not sense the fault current, and the LVPCB will trip on long-time pickup at a time that may exceed the generator 10-s sustained fault capability. For example, during fault conditions, if the AVR maintains the same exciter field voltage as before the fault (the AVR fails to increase the exciter field voltage) the fault current will decay as the generator transitions through subtransient, transient, and synchronous reactance parameters. If this occurs and the MCCB or LVPCB does not interrupt the fault before the generator transitions to the synchronous reactance, then the fault will not be interrupted as soon as anticipated.

To overcome these limitations, a 51-V time-overcurrent voltage-restraint or voltage-controlled relay can be implemented [3], [5]. As shown in Fig. 8, the 51-V relay with definite time characteristic offers the advantage that it can be set for predictable relay response and time selectivity with downstream protective devices. For the voltage-controlled 51-V device, the relay can be set to respond when the system bus voltage is depressed below 70%. The relay current pickup is usually set at 25% of the generator full-load amperes to protect the generator for classical ac current decrement when the field forcing is not functioning. If a voltage-restraint 51-V relay is utilized, the typical current setting would be approximately 150% of generator full-load current. When zero terminal voltage is detected, the pickup curve shifts to 25% of the overcurrent setting. If the

51-V relay is not utilized or the 51-V relay trip signal fails to trip the LVPCB within 10 s, generator damage can occur. The 51-V relay pickup within 10 s should be confirmed with the generator decrement curve and excitation system thermal limit. Unattended installations may have an undervoltage (27-BU) relay to initiate a generator circuit breaker trip within 10 s for severe undervoltage conditions.

The 51-V relays provide increased sensitivity for high impedance arcing faults and generator field limited forcing capability applications. Self-excited standby generators normally have a fast short-circuit output decrement and may be better protected with 51-V relays for improved sensitivity. However, due to the increased sensitivity at the generator, overall system coordination is generally more difficult to accomplish when 51-V inverse-time relays are applied.

XII. UPS SYSTEM TYPES AND SHORT-CIRCUIT CONSIDERATIONS

The three predominant online UPS system types typically used today are step-wave, pulsewidth-modulated (PWM), and ferroresonant types. The step-wave and PWM types can be specified with a short-circuit capability of $1.5\times$ the full load. It is understood a ferroresonant-type UPS output filter has the energy available to supply a maximum short-circuit current of $5\times$ full-load amperes for approximately 0.25 cycles. The ferroresonant available short-circuit current is a function of the load and the voltage supplied by the inverter to the output filter just before the fault occurs. As the fault progresses, the output filter energy is supplied to the downstream loads and the fault resulting in 0.25-cycle fault current support before quickly reducing to $1.5\times$ full-load amperes. With such short-time fault current limitations, it is intuitive that UPS short-circuit current support may be insufficient to clear some downstream protection configurations.

During a fault condition, the UPS output voltage rapidly collapses. The static transfer switch senses the reduced low voltage and switches from the inverter output to the alternate source. The alternate source has significantly greater short-circuit capability, and with the increased fault current available, the fault can be cleared. The level of fault current available from the alternate source does stress the static switch by requiring the SCRs to “make” into a fault. For this sequence to work, the alternate source is assumed available, thereby providing a significant reason for powering the alternate source feed from the standby generator bus.

Transfer to the alternate source occurs in 0.25–0.5 cycles after the voltage dips below the static transfer switch undervoltage set point. These set points vary among manufacturers, but, generally, UPS systems try to assure that the bus voltage will be maintained within the CBEMA curve voltage guideline (Fig. 9) to maintain operation of critical instrumentation during all system conditions.

During fault conditions, maintaining the CBEMA curve voltage profile is dependent on the fault magnitude and the downstream protective device clearing time. Manufacturers recommend that the downstream UPS distribution system consist of fast-acting current-limiting fuses with 0.5-cycle or less

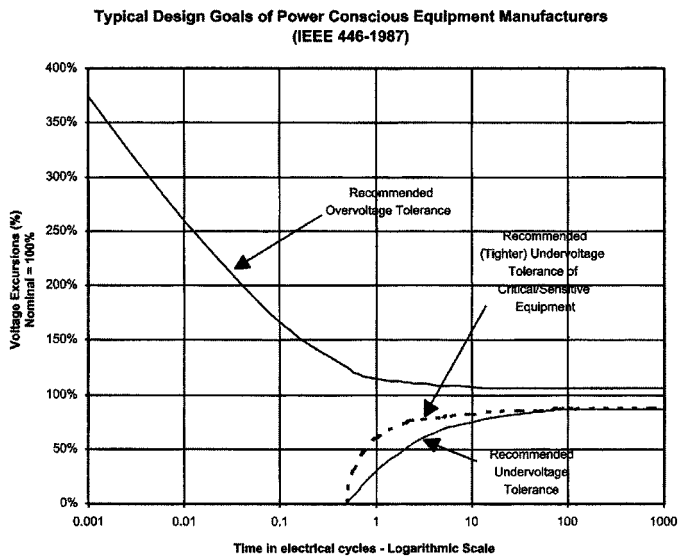

Fig. 9. CBEMA curve.

clearing time with sufficient fault current. In most instances, fast-acting fuses interrupt the fault from inverter-supplied current, and the distribution system remains on the UPS inverter.

Because MCCB indoor panelboards are typically used for general-purpose service in process plant control rooms, switchgear rooms, and office buildings, it is a natural choice to use them in a UPS distribution system. However, when making this decision, it is important to understand the potential consequences of this selection. Panelboard MCCB clearing times are nonadjustable, and may require 1.1–1.5 cycles for fault clearing [9]. If a fault persists, the inverter voltage decays and the UPS static transfer switch transitions to the alternate source. This results in a 1.35–2-cycle total clearing time, including time to transfer to the alternate source and circuit breaker interruption. If the CBEMA curve is viewed as a benchmark during these 1.35–2 cycles, the voltage collapse could have a devastating effect on the downstream instrumentation (Fig. 9).

XIII. UPS STATIC TRANSFER SWITCH SHORT-CIRCUIT RATING

Static transfer switches are semiconductor devices designed to transfer the load to the alternate source during a UPS voltage dip. If the UPS inverter fault current cannot interrupt a load-side fault, the static switch will transfer to the alternate source for fault current support as discussed above. The typical static transfer switch has a fault current rating of $10\times$ the full-load switch rating for 1–5 cycles, and is often supplied with internal upstream solid-state fuses to protect the static transfer switch. Obviously, downstream branch circuit protective devices must be selective with the upstream fuse protecting the static transfer switch. This selectivity assures that downstream branch circuit faults are interrupted by the branch circuit protection and that power continuity is maintained to the downstream loads. If the static transfer switch upstream fuse protection is not supplied, protection coordination must be reviewed with the static transfer switch capability curve to confirm that switch damage will not occur.

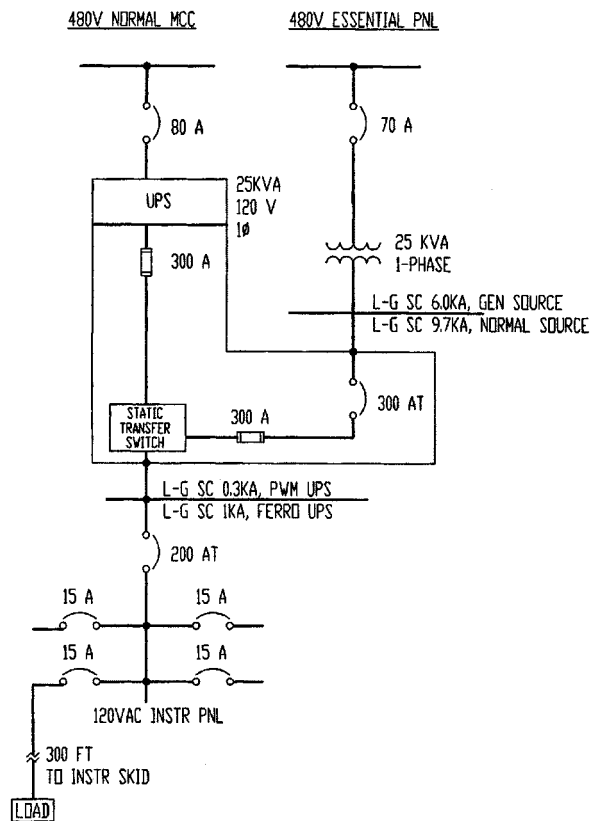

Fig. 10. Typical UPS system configuration with single-phase loads.

XIV. UPS SYSTEM SHORT-CIRCUIT CRITERIA—SINGLE PHASE VERSUS THREE PHASE

The above UPS system short-circuit discussions indicate the importance of sufficient fault current for protective device sensing and circuit interruption without requiring transfer to the alternate supply. One way to increase fault current without affecting system design is to select a single-phase UPS system instead of a three-phase system. If output phase-to-phase voltages are identical, a single-phase UPS inverter configuration can supply approximately $1.732\times$ the short-circuit current of an equivalent kilovoltampere-rated three-phase UPS system. Also, the typical plant UPS system loads are single phase and do not require a three-phase source. Single-phase UPS systems are usually available, even in relatively large kilovoltampere sizes.

XV. UPS SYSTEM SELECTIVITY CONSIDERATIONS

The Fig. 10 one-line diagram expands the UPS system in Fig. 1 and shows the internal UPS system protective devices and the downstream distribution system configuration.

Also shown are the short-circuit currents from the UPS inverter and the alternate source. It is important that short-circuit withstand and coordination curve data for all integral UPS protective devices are included in the purchase order specification. For the example in Fig. 11, the 25-kVA ferroresonant-type UPS system available fault current for the first 0.25 cycle is approximately 1040 A ($5\times$ full-load current); the PWM type provides an available fault current of approximately 312 A ($1.5\times$

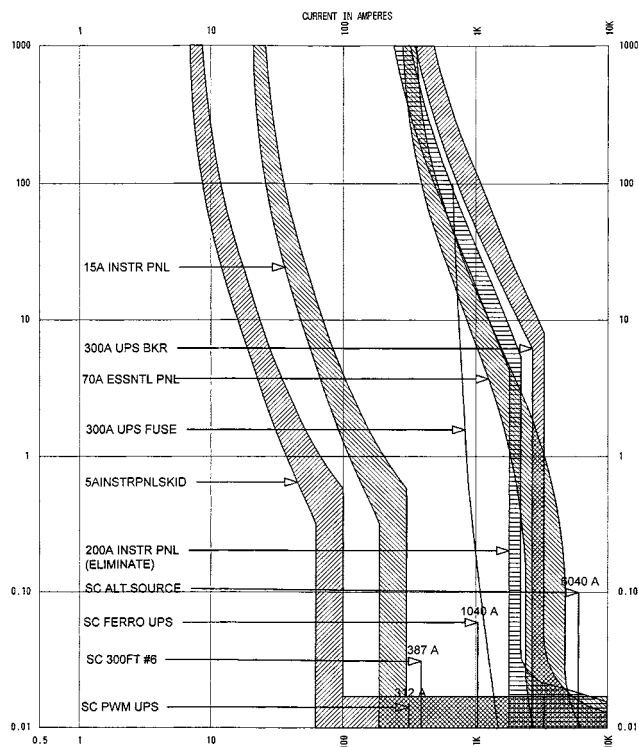

Fig. 11. UPS system configuration with instrument panel MCCBs. Current scale $\times 1$. Reference voltage 120 V.

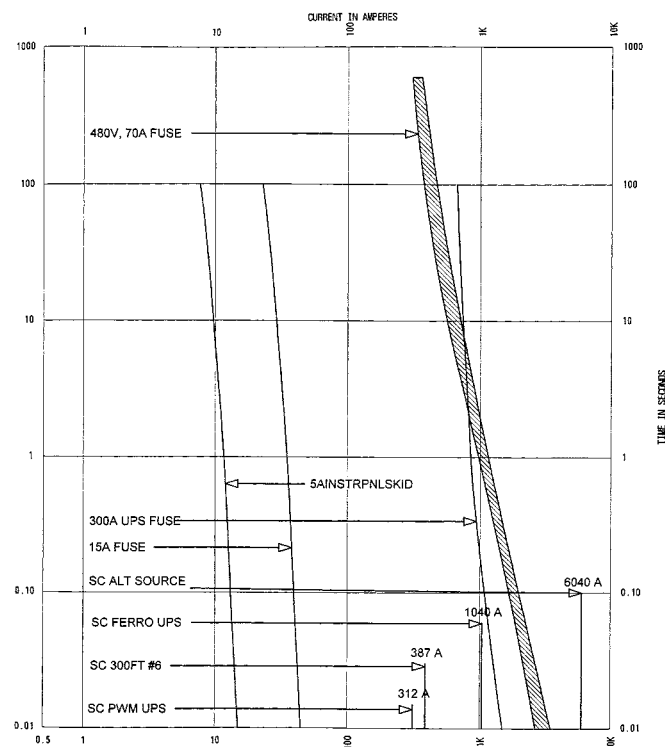

Fig. 12. UPS system configuration with instrument panel CL fuses. Current scale $\times 1$. Reference voltage 120 V.

TABLE III
VARIATIONS IN FAULT CURRENT FOR FIELD-LOCATED FAULT PROTECTION

One-way cable length	Fault current at distribution pnl.	Fault current at load
150 ft # 10	1040 amps	154 amps
150 ft # 8	1040 amps	246 amps
150 ft # 6	1040 amps	387 amps

full-load current). Fig. 11 shows that both UPS types produce insufficient fault current to quickly clear a 200-A Instrument Panel Main circuit breaker. To clear a fault involving the Instrument Panel Main requires the static transfer switch to operate, transferring the fault to the alternate source where 6040 A is available. Further evaluation of the Instrument Panel Main concludes that very little protection is added by having this circuit breaker or fused disconnect device in the system, and it should be removed. Compliance with NFPA 70, 1999, Article 384, must be confirmed. Obviously, if the main lugs only panelboard is installed it should be sized to match upstream protection.

As a point of interest, Table III shows the result of the 150-ft one-way cable length (300-ft “round-trip” total circuit length) between the Control Room Instrument Panel and a skid-mounted instrument panel, such as those found on an instrument air compressor. The table indicates that special consideration must be given to cable sizing to assure adequate fault current for downstream protective device fault clearing. If a 15-A circuit breaker is located at the instrument panel and a 5-A circuit breaker at the skid, the wire impedance may limit the fault current at the skid below the pick up of the 15-A breakers, thereby maintaining selectivity. In some cases, an increased cable size may be needed to increase the available

fault current at remote downstream skid-mounted loads for protective device sensing and selectivity reasons. The impact of three typical cable sizes (#10, #8, and #6) are shown for comparison purposes.

When the alternate supply is the fault-clearing source, it is imperative to consider the downstream protection when sizing the alternate supply step-down transformer. In Fig. 10, a 25-kVA transformer with a 2.0% impedance produces an available fault current of approximately 6040 A when powered by the standby generator.

Fig. 11 shows that high-magnitude alternate source fault currents are sufficient to trip the Instrument Panel 15-A branch circuit breaker, and nuisance trip the Instrument Panel 200-A main breaker, 300-A UPS internal fuse and circuit breaker, and 480-V 70-A Essential Panel feeder breaker.

To overcome these selectivity limitations, current-limiting fuses are recommended throughout the 120-Vac UPS distribution system, and at the 480-V Essential Panel feeder to the UPS alternate source transformer. Fig. 12 shows a system that achieves greater selectivity by using fast-acting current-limiting fuses at the Instrument Panel branch circuit feeder breakers, UPS internal fuses, and the 480-V feeder breaker to the UPS alternate-source transformer. The Instrument Panel main breaker is deleted. Making these panelboard and MCC fuse changes and coordinating with the UPS manufacturer improves system selectivity for devices downstream of the alternate source transformer secondary. For selective coordination, fuses must be selected according to fuse manufacturer guidelines. This modification will provide fast fault clearing, enhancing plant safety and reliability.

XVI. SUMMARY

The following summarizes the salient points of the three-wire 480-V distribution system and the single-phase UPS system discussed in this paper.

- 1) The modern generator excitation support system uses a PMG for sustained short-circuit current considerations. However, if a choice must be made between self-excited and PMG types, the PMG excitation system with field forcing should be specified because of the significantly increased level of sustained short-circuit current capability.
- 2) Standby generator governor control systems tuning should be thoroughly evaluated during factory testing and field startup for predictable driver response and to minimize driver overspeed tripping during fault conditions. A full-load rejection test is a valuable field test to demonstrate the speed of response.
- 3) A generator 51-V relay should be considered on standby generators to protect the system so that low-magnitude phase faults are predictably detected and interrupted by the generator circuit breaker once system voltage has decayed. Self-excited standby generators may be better protected with 51-V relays for improved sensitivity. A 27-BU undervoltage relay with a definite-time timer should be considered for unattended standby generator protection to insure fault removal before the generator 10-s heating limit during phase faults.
- 4) The use of definite time characteristic protection devices should be considered for upstream generator system circuit breakers so that more easily predictable interrupting times are achieved.
- 5) Because NEMA Standard MG1 does not require generator bracing for line-to-ground faults, the application engineer must obtain manufacturers confirmation that a solidly grounded generator has been designed to endure line-to-ground faults and that machine design stresses are not exceeded.
- 6) A 51 G ground fault relay and CT should be provided in the Essential MCC generator neutral grounding circuit of solidly grounded generators to increase relay sensitivity during system ground faults. Separate ground fault protection should be considered on each 480-V Essential MCC feeder breaker for detection of low-magnitude ground faults. (An MCCB dc shunt trip should be used to insure tripping power after bus voltage collapse.)
- 7) When paralleling neutral-grounded generators, the generator winding pitch factor must be thoroughly reviewed with the generator manufacturer so that third harmonic overheating is minimized. When a generator 2/3 winding pitch factor is provided, third harmonic heating currents are not produced, however, generator zero-sequence reactance is significantly reduced and solidly grounded generator line-to-ground faults are potentially greater than three-phase fault magnitudes.
- 8) When applicable, standby generator installations with high-resistance grounding may be considered so the initial ground fault does not impact process operation during a time when critical loads are operating on the standby generator. Essential MCC phase-to-phase voltage is maintained even during a line-to-ground fault, enhancing system safety and process reliability. NEC compliance and familiarity of plant operating personnel capabilities are important concerns when considering this system application.
- 9) Tables I and II illustrate that low-voltage cables introduce significant impedance that greatly reduce available short-circuit currents. This makes predicting selectivity difficult. When considering the fault impedance for arcing faults (which can be significant when compared to the system driving voltage), the combined effect can result in the actual fault current being very low, making detection difficult. These selectivity difficulties often make it necessary to vastly expand the scope of standby power and UPS coordination studies to include the largest protective device of various vendor supplied skids.
- 10) Essential MCCs should incorporate an insulated equipment bus, phase barriers, insulating boots, and tape so that fault probability is significantly reduced. Premium components should be applied throughout the essential load system for security reasons.
- 11) When an ATS is used, current-limiting fuses or MCCBs with instantaneous trip elements are needed to protect the 1.5- or 3-cycle ATS short-circuit withstand capability. The LVPCB with instantaneous element can be considered for use with a 3-cycle ATS withstand rating. The LVPCB total clearing time (including static trip "wake-up" time) must be thoroughly reviewed to confirm that circuit interruption can protect a 3-cycle ATS withstand capability.
- 12) Recent availability of a 30-cycle ATS (in larger ATS ampacity sizes) enables upstream protection to be time-delayed, often improving selectivity.
- 13) An alternate generator standby system configuration using LVPCBs, without an ATS, should be reviewed for system selectivity, security, and cost considerations.
- 14) Ferroresonant-type UPS inverters generally have a high momentary short-circuit current contribution during the first 0.25 cycles and may assist in fast-acting fuse selectivity so that transfer to the alternate source does not occur.
- 15) UPS system manufacturers recommend fast-acting current-limiting fuses for all downstream protection for fast clearing of low-magnitude faults, thereby minimizing the need for the static switch transferring to alternate source to supply sufficient fault current. The fuse sizes should be small when compared to the fault current available.
- 16) Single-phase UPS systems are preferred to equivalent kilovoltampere three-phase systems because of the increased fault current available from the single-phase type.
- 17) Provide special attention to the reduced fault current magnitude when 120-Vac remote skid-mounted loads

are powered from the UPS system instrument panels. Increased cable sizes may be required to assure selective fault clearing for a local instrument panel, avoiding an extended voltage collapse and loss of panel loads.

- 18) Skid-mounted equipment, ATSS, transformers, ground resistors, cable, protective relays, UPS systems, and standby generators all have damage withstand characteristics. Coordination study protective devices must be reviewed to assure that equipment withstand capabilities are protected. This necessitates requesting equipment manufacturer data early in the project.

VII. CONCLUSIONS

When designing backup power systems for critical plant loads, there must be a complete understanding of the system elements, loads, and protective devices during steady-state and fault conditions. Understanding the degree of selectivity achieved between protective devices is important to assure that process loads are protected from prolonged voltage collapse during fault conditions.

Consequently, it is the application engineer's responsibility to perform a comprehensive equipment review and verification with the manufacturers so system response is well understood and system limitations are known early in the project. Relevant points and data included in this paper should be independently verified. Investigation of applicable codes, standards, underwriter's requirements, and a wide variety of application guides such as the IEEE Color Books should also be performed. This will enable the application engineer to provide well-thought-out alternatives to achieve complete protective device selectivity and to maintain critical process loads during fault conditions. This will enhance plant process safety for operators, engineers, and office personnel.

ACKNOWLEDGMENT

The authors acknowledge P. Evjen and J. Dunn for their helpful suggestions in the development of this paper.

REFERENCES

- [1] *Recommended Practice for Emergency and Standby Power Systems for Industrial and Commercial Applications*, (IEEE Orange Book), ANSI/IEEE Std. 446-1995.
- [2] A. E. Fitzgerald, C. Kingsley, Jr., and A. Kusko, *Electric Machinery*, 3rd ed. New York: McGraw-Hill, 1971, ch. 10.
- [3] D. Ventruella, "A second look at generator 51-V relays," *IEEE Trans. Ind. Applicat.*, vol. 33, pp. 848–856, May/June 1997.
- [4] *Standard for Safety Transfer Switch Equipment*, ANSI/UL-1008-1996.
- [5] D. S. Baker, "Generator backup/overcurrent protection," *IEEE Trans. Ind. Applicat.*, vol. IA-18, pp. 632–640, Nov./Dec. 1982.
- [6] M. S. Griffith, "Modern AC generator control systems: Some plain and painless facts," *IEEE Trans. Ind. Applicat.*, vol. IA-14, pp. 481–491, Nov./Dec. 1978.
- [7] Solid State Controls. (1998, November 14) Why fuses instead of breakers for UPS distribution panels. *FAQ's & Information* [Online]. Available: <http://www.solidstatecontrolsinc.com/faqs/index.html>

- [8] Cyberex, Inc., "UPS: Single-phase output," *CyberWave Bull.* 94-58-98008, vol. 98, no. 2.
- [9] *IEEE Recommended Practice for Applying Low-Voltage Circuit Breakers Used in Industrial and Commercial Power Systems*, (IEEE Blue Book), ANSI/IEEE Std. 1015-1997.
- [10] *Motors and Generators*, NEMA Std. MG1-1993, Rev. 4, June 1997.
- [11] *IEEE Recommended Practice for Electric Power Distribution for Industrial Plants*, (IEEE Red Book), ANSI/IEEE Std. 141-1993.
- [12] *National Electrical Code, 1999 Edition*, NFPA 70.
- [13] *IEEE Recommended Practice for Grounding of Industrial and Commercial Power Systems*, (IEEE Green Book), ANSI/IEEE Std. 142-1991.



Roy E. Cossé, Jr. (S'66–M'68–SM'99) received the B.S.E.E. and M.S.E.E. degrees from the University of Southwestern Louisiana, Lafayette, in 1968 and 1972, respectively.

He has 30 years of electrical engineering experience in the petrochemical/marine/pipeline/cogeneration industries. His experience encompasses conceptual design, detailed engineering, training, startup, maintenance, and operations, with a specialty in power system analysis. He is currently with Powell Electrical Manufacturing Company,

Houston, TX, where he is a Coordinator for PowlTech Advanced Technical Services.

Mr. Cossé has presented numerous technical seminars for the IEEE Houston Section Continuing Education On Demand. He is a Professional Engineer in the States of Texas and Louisiana.



James E. Bowen (M'83) received the B.S.E.E. degree from Texas A&M University, College Station, in 1976.

After working for S.I.P. Engineering as a Power Engineer for three years, he joined Exxon Chemicals in 1979. His duties included maintenance, project design, construction follow-up, and commissioning for petrochemical and cogeneration processes. In 1997, he joined Powell Electrical Manufacturing Company, Houston, TX, as Technical Director, where he provides leadership in the design development of medium-voltage switchgear and circuit breakers.

Mr. Bowen has presented numerous technical seminars for the IEEE Houston Section Continuing Education On Demand. He is a Professional Engineer in the State of Texas.



William H. Nichols (M'74) received the B.S.E.E. degree from Texas A&M University, College Station, and the M.E.E. degree from the University of Houston, Houston, TX, in 1964 and 1973, respectively.

In January 1965, he joined Westinghouse Electric Corporation, and he is presently an Application Engineer with Siemens Westinghouse Technical Services, Houston, TX. He has more than 35 years of advanced electrical technology experience in the industrial sector as an application specialist.

He specializes in power system analysis and major electrical equipment application.

Mr. Nichols has presented numerous technical seminars for the IEEE Houston Section Continuing Education On Demand. He is a Professional Engineer in several states.