



A survey of medium voltage drives, specifications, and practical challenges

IEEE Houston Section, CED Seminar, February 2017

Presenter: Navid Binesh
Medium Voltage Products Applications

©2017 Regal Beloit Corporation, Proprietary and Confidential



REGAL[®]

Agenda



❖ Induction Motors

- Basics of Induction Motors
- Main Challenges of Induction Motors
- Starting of Induction Motors
- Speed Control of Induction Motors
- Power Factor of Induction Motors

NOT FOR DISTRIBUTION

Agenda



- ❖ **Variable Frequency Drives – General**
- Basics of Variable Frequency Drives
- Benefits of VFDs
- Main Components of VFDs
- Basics of Rectifiers
- Basics of Inverters
- Types of Loads
- VFD Output Waveform Quality & Solutions
- VFD Input Power Quality & Solutions
- Reliability of VFDs
- Serviceability of VFDs
- How to specify a VFD

NOT FOR DISTRIBUTION

Agenda



❖ **Variable Frequency Drives – MV**

- Overview of MV Drive Topologies
- Current Source vs. Voltage Source
- Neutral Point Clamp
- Cascaded Neutral Point Clamp
- Cascaded H-Bridge
- Modular Multi-Level
- Installation Flexibility and Benefits
- Scalability and Benefits
- Arc Flash Detection System

NOT FOR DISTRIBUTION



Induction Motors

AC Motors in Industry

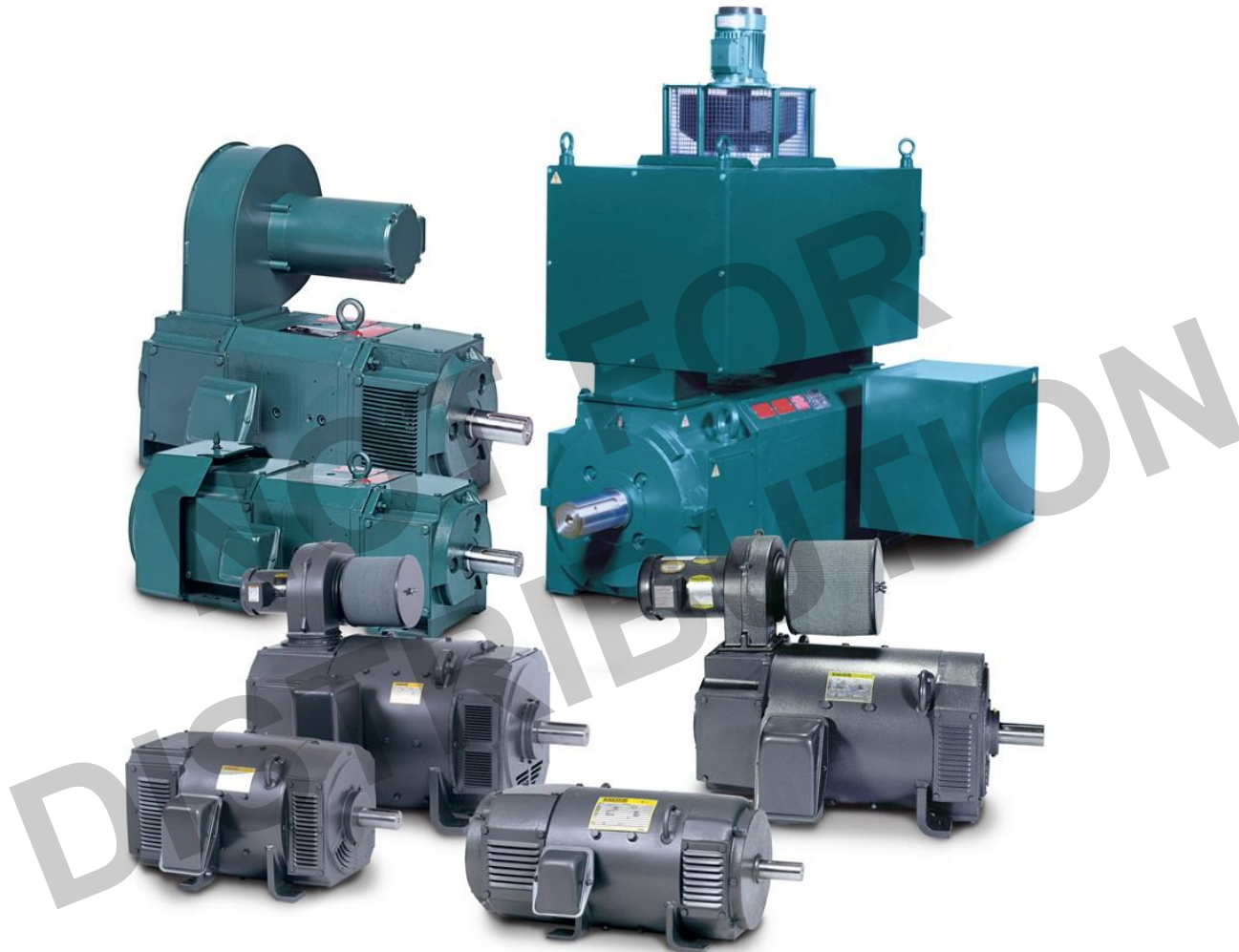

They run our industries!

AC Motors in Industry



History of AC Motors

- 1882 – Nikola Tesla is a Croatian engineer / scientist studying in Graz, Austria and performing experiments on multi-phase voltage system.
- 1884 – Tesla emigrates to America and immediately starts working for Thomas Edison at Edison Machine Works in New York.
- 1884 – Edison disagrees with Tesla’s idea of running a motor with AC power. Tesla quits shortly after. This is the beginning of “the war of the currents”.
- 1886 – Tesla starts his small company and development laboratory.

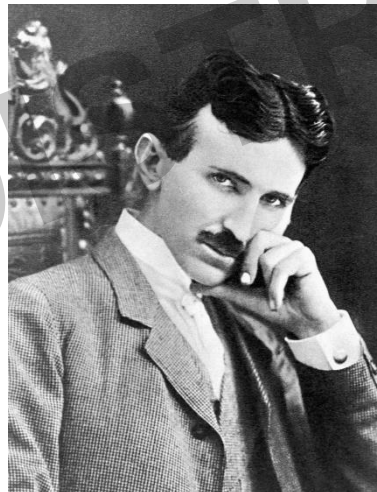

AC Motors in Industry

History of AC Motors

- 1887 – Tesla files his first patents for a two-phase AC system with four electric power lines, which consists of a generator, a transmission system and a motor.
- 1888 – George Westinghouse becomes aware of Tesla due to his remarkable speech in Pittsburgh to the American Institute of Electrical Engineers (father of IEEE). Westinghouse buys his more than 40 patents for \$1M and hires Tesla as a consultant.
- 1892 and 1893 – First reliable three-phase induction motors are built by AEG company in Germany and Westinghouse Electric & Manufacturing Company in US.

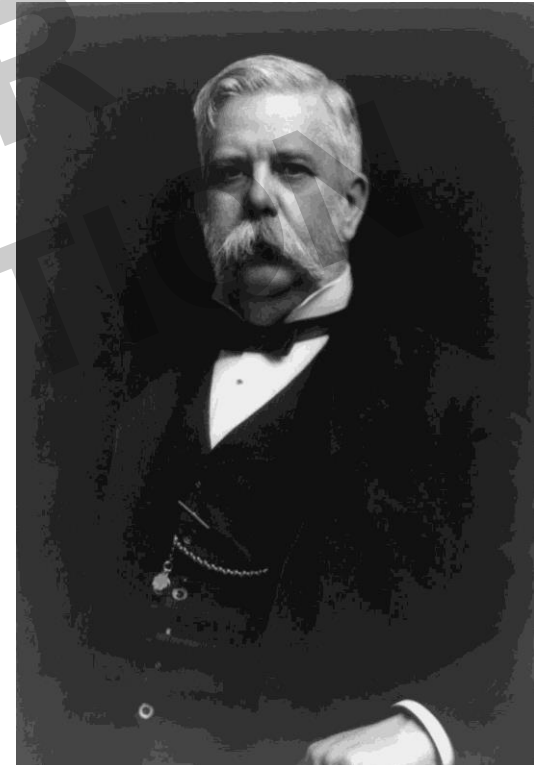

AC Motors in Industry



Current Status of AC Motors

- Most common and frequently encountered machines in industry
- Simple design, easy to manufacture, low-price, easy maintenance
- Wide range of power ratings: fractional horsepower to tens of MW
- Used in almost every industry: Oil & Gas, Water & Wastewater, Mining & Minerals, Cement & Asphalt, Aggregate & Quarry, Material handling, Agriculture, and HVAC.
- Used in almost every process: Pumps, Fans, Compressors, Blowers, Centrifuges, Cranes, Conveyors, Mills, Extruders, Mixers, Winders
- Many type of AC motors
 - Induction motors
 - Synchronous motors
- Induction motors are the most common type of motors in use today
- Motors are manufactured to NEMA and IEC standards

Induction Motors



Construction

- Each motor is consisted of three main sections:
 - Stator
 - Rotor
 - Enclosure and cooling

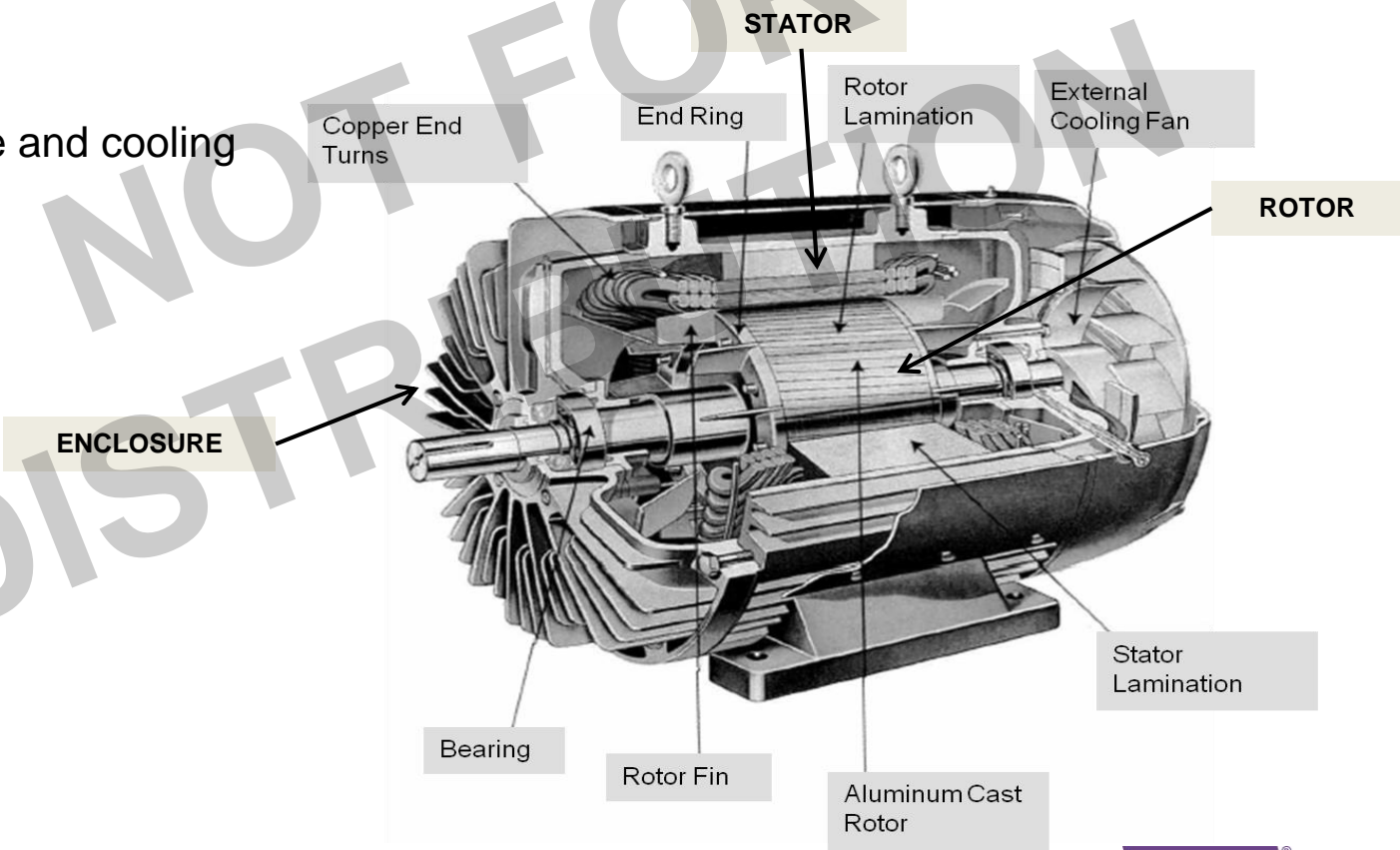

Induction Motors

Construction

- A stationary stator
 - Provides space for three-phase windings made of insulated wires (cables)
- A revolving rotor
 - Provides space for rotor windings (Squirrel-cage or Wound-rotor)

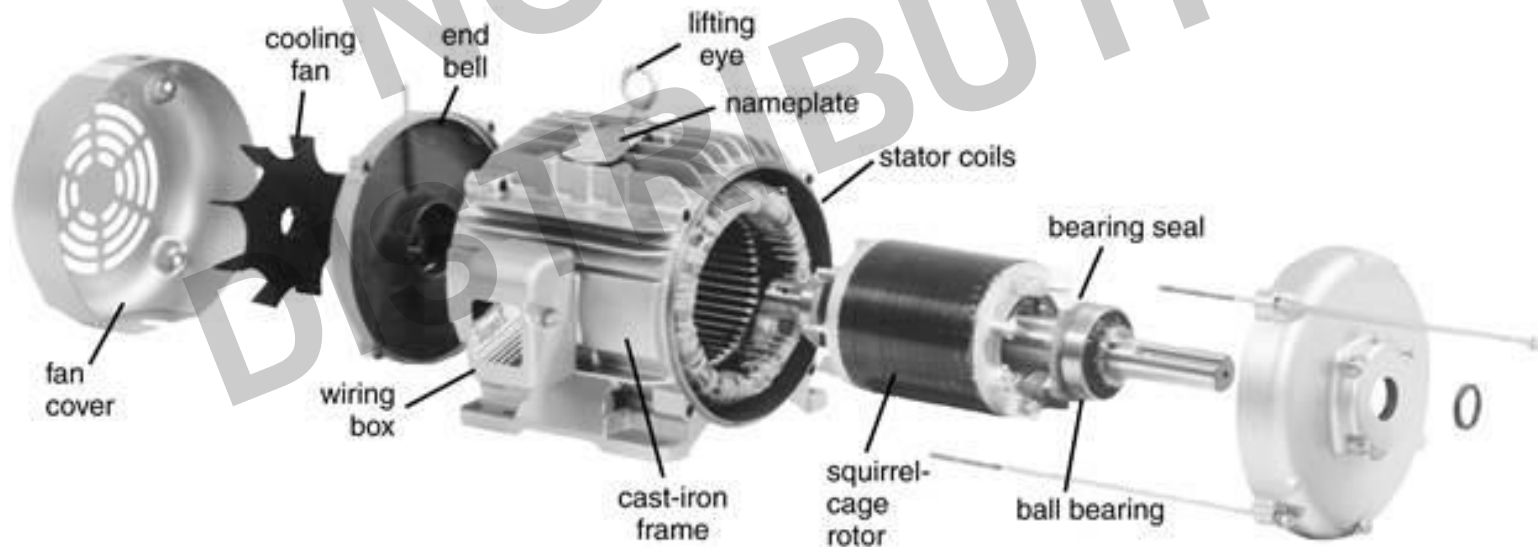

Induction Motors

Principle of Operation

- Stator windings are supplied by 3-phase AC power.
- The combined effect of the individual magnetic fields produces a single, rotating magnetic field in the air gap. 3-phase AC power on stator windings generate rotating magnetic field.

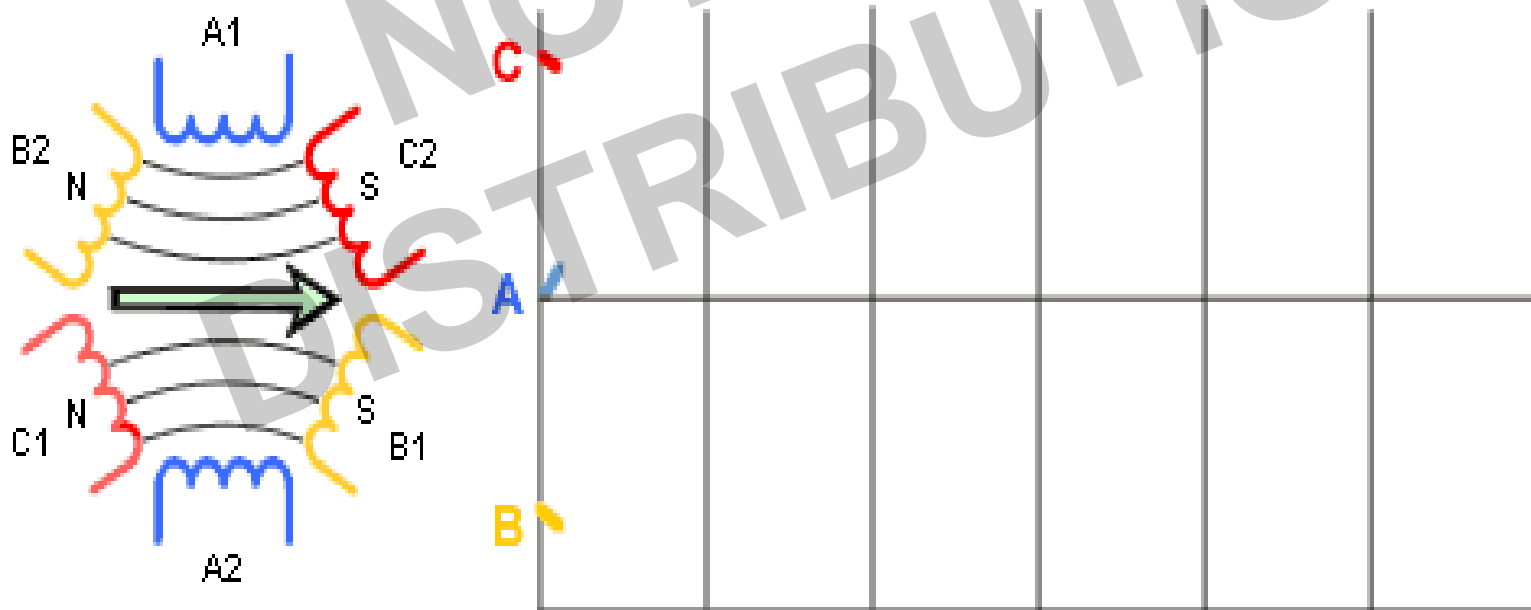

Induction Motors

Principle of Operation

- This rotating magnetic field cuts the rotor windings and produces an induced voltage in the rotor windings.
- Due to the fact that the rotor windings are short circuited, an induced current flows in the rotor windings.
- The rotor current produces another magnetic field.

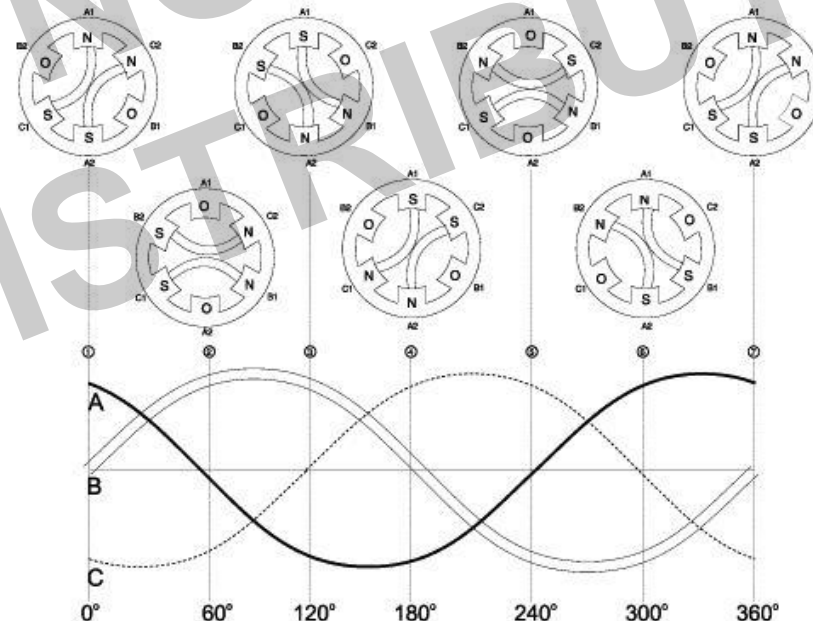

Induction Motors

Principle of Operation

- A torque is produced as a result of the interaction of two magnetic fields. The torque causes rotor to rotate.
- The torque is produced only when the rotor does not seem stationary to the stator's rotating magnetic field.
- The speed of rotating magnetic field is called synchronous speed. The rotor rotates at a speed slower than this speed.
- The induction motors are also called asynchronous motors.

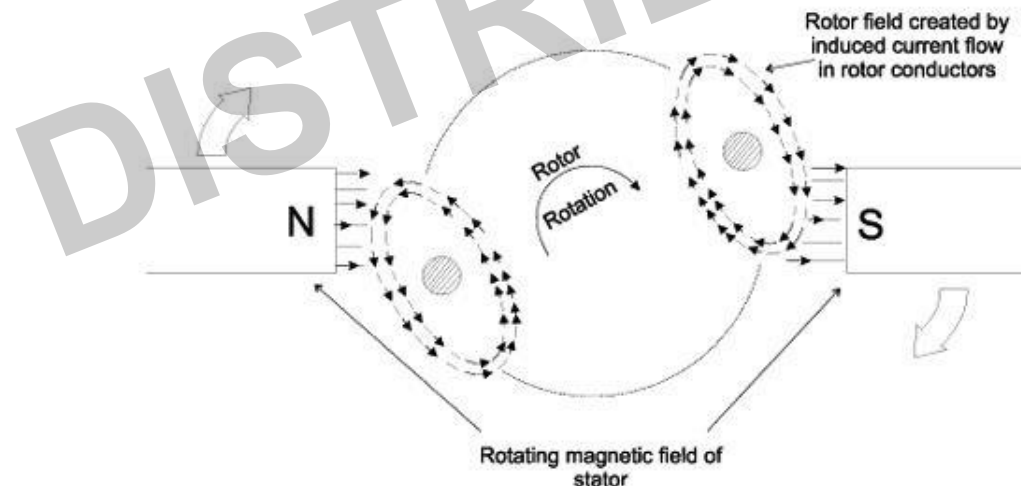

Motor Speed and Synchronous Speed

- Synchronous speed is the rotating speed of the stator's magnetic field.
- Synchronous speed depends on the frequency of supply to stator and the number of poles in the motor.
- The synchronous speed is given by the following equation:

$$n_s = \frac{120 * f}{P}$$

- The motor speed and synchronous speed are measured by number of revolutions per minute (RPM).
- 3600, 1800, 1200, 900
- The motor speed is very close to the synchronous speed.
- To change the synchronous speed the supply frequency or number of poles in the motor has to change.

Motor Speed and Slip

- Induction motors always run at a speed lower than the synchronous speed.
- The difference between the motor speed and the synchronous speed is expressed by slip.

$$s = \frac{n_s - nr}{n_s}$$

- Slip is typically in a range of 0.5% to 5%.
- Slip depends on motor design (parameters) and load. At low values, slip is directly proportional to the rotor resistance, stator voltage frequency and load torque, and inversely proportional to the second power of supply voltage.
- The slip of low-HP motors is higher than that of high-HP motors because the resistance of the rotor's winding is greater in smaller motors.
- To change the slip for a specific load, the rotor's winding resistance has to change.

Induction Motors

Motor Nameplate

- Rated power (HP and / or kW)
- Rated voltage
- Rated full-load current (FLA)
- Frequency
- Rated full-load speed
- Rated full-load power factor (PF)
- Number of poles
- Number of phases
- Service factor (S.F.)
- Nominal efficiency
- NEMA design
- Rated ambient temperature
- Insulation class

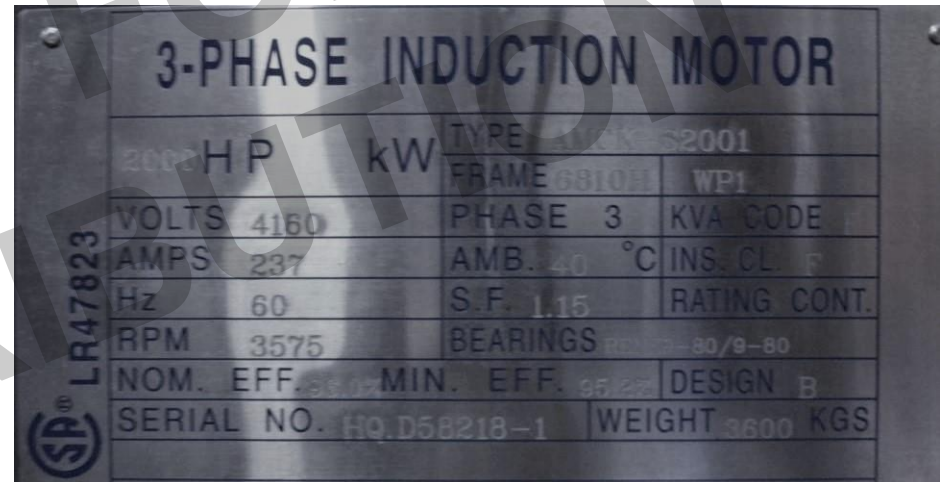

3-PHASE INDUCTION MOTOR

SR® LR47823	2000 HP	kW	TYPE	32001	
			FRAME	6810H WPI	
	VOLTS	4160	PHASE	3 KVA CODE	
	AMPS	237	AMB.	40 °C INS. CL. F	
	Hz	60	S.F.	1.15 RATING CONT.	
	RPM	3575	BEARINGS	30/9-80	
	NOM. EFF.	95.02	MIN. EFF.	95.22 DESIGN B	
	SERIAL NO.	HQ.D58218-1		WEIGHT	3600 KGS

Induction Motors



Motor Speed and Motor Torque

- Torque is a force that causes rotation.
- Motor Speed – Torque profile shows the amount of torque that the motor can generate at each speed.
- Induction motors are classified by NEMA as NEMA A, B, C and D based on their Speed – Torque profile.
- The full-load torque (lb.ft) of the motor can be calculated by the following formula:

$$T = \frac{5250 * HP}{n_r}$$

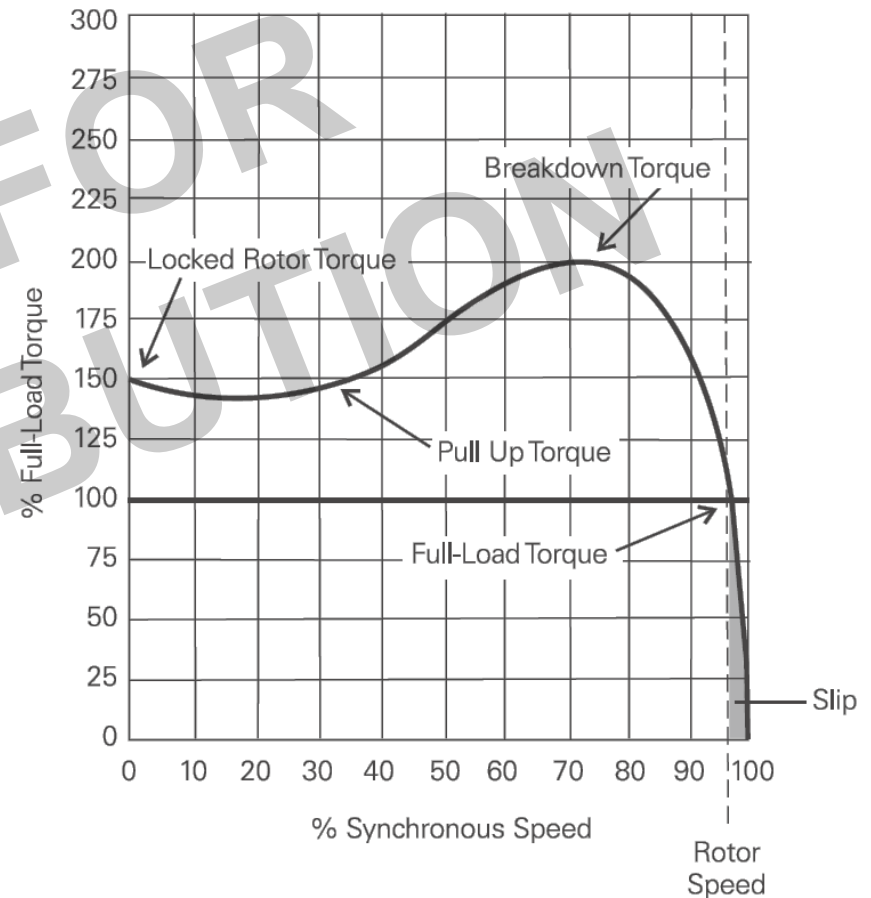

Induction Motors



NEMA A Design

- Normal locked rotor (starting) torque (100 - 150%)
- High breakdown torque (200 - 250%)
- High starting current (700 - 900%)
- Low full load slip (0.5 - 3%)
- High efficiency
- Used in applications that require:
 - Occasional overloads
 - Very high efficiency
- Typical loads:
 - Fans
 - Blowers
 - Centrifugal pumps
 - Compressors

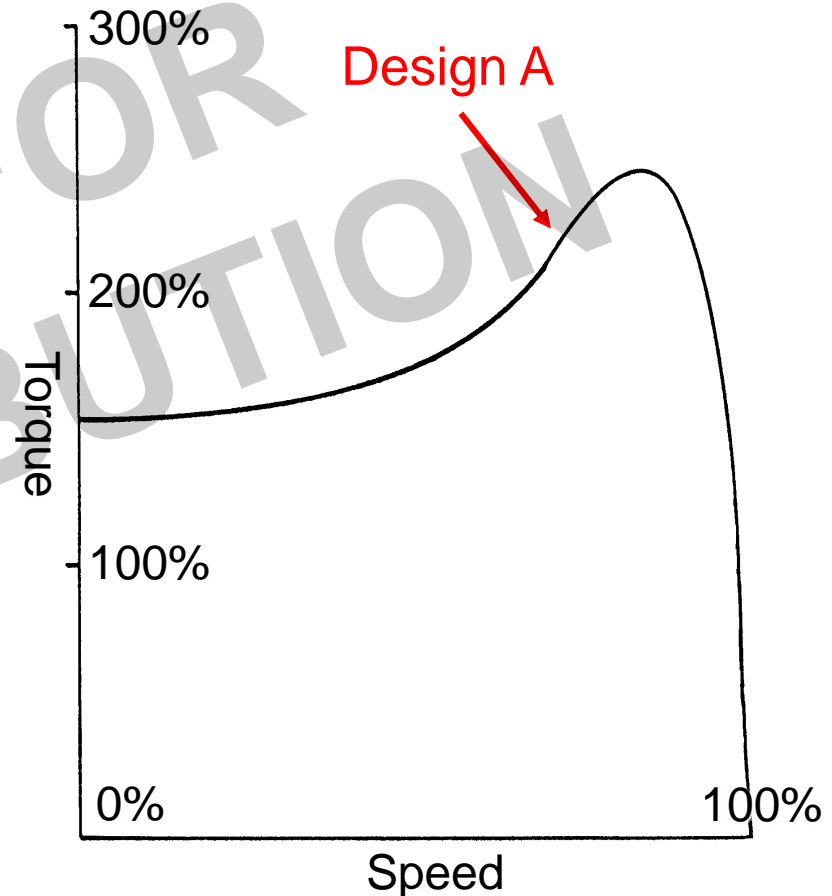

Induction Motors



NEMA B Design

- Normal locked rotor (starting) torque (100 - 150%)
- Normal breakdown torque (150 - 200%)
- Normal starting current (600 - 700%)
- Normal full load slip (1 – 5%)
- Medium or high efficiency
- Used in applications that require:
 - Low starting torque
- Typical loads:
 - Fans
 - Blowers
 - Centrifugal pumps
 - Compressors

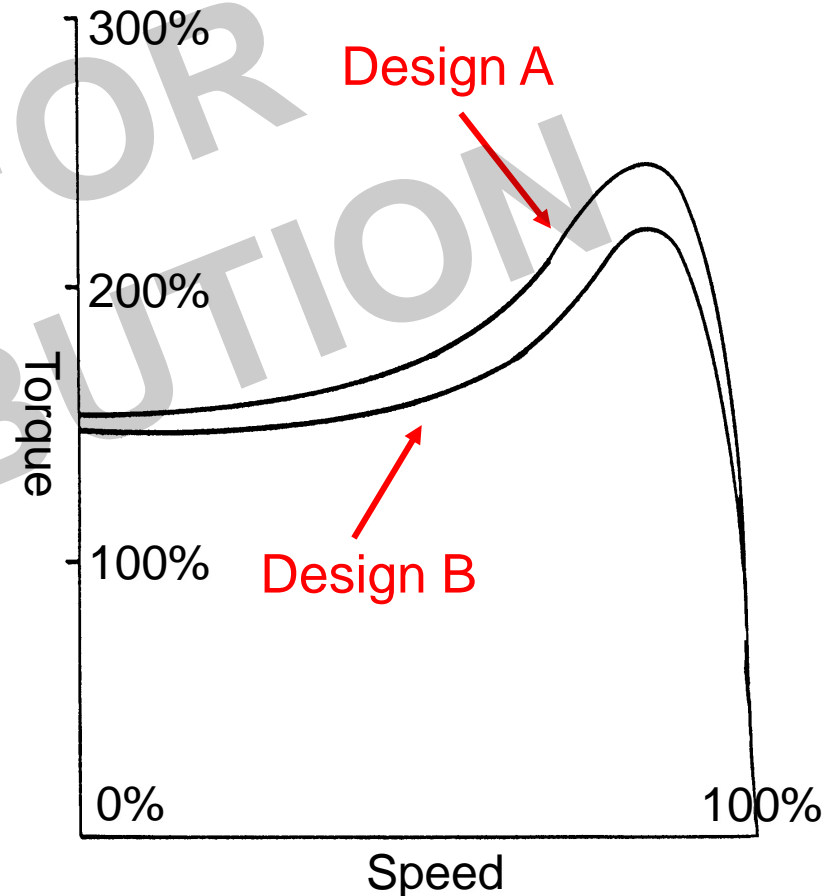

Induction Motors



NEMA C Design

- High locked rotor (starting) torque (200 - 250%)
- Low breakdown torque (150 - 200%)
- Normal starting current (600 – 700%)
- Normal full load slip (1 – 5%)
- Medium efficiency
- Used in applications that require:
 - High breakaway (starting) torque
- Typical loads:
 - Conveyors
 - Crushers
 - Reciprocating pumps
 - Compressors
 - Stirring machines and agitators

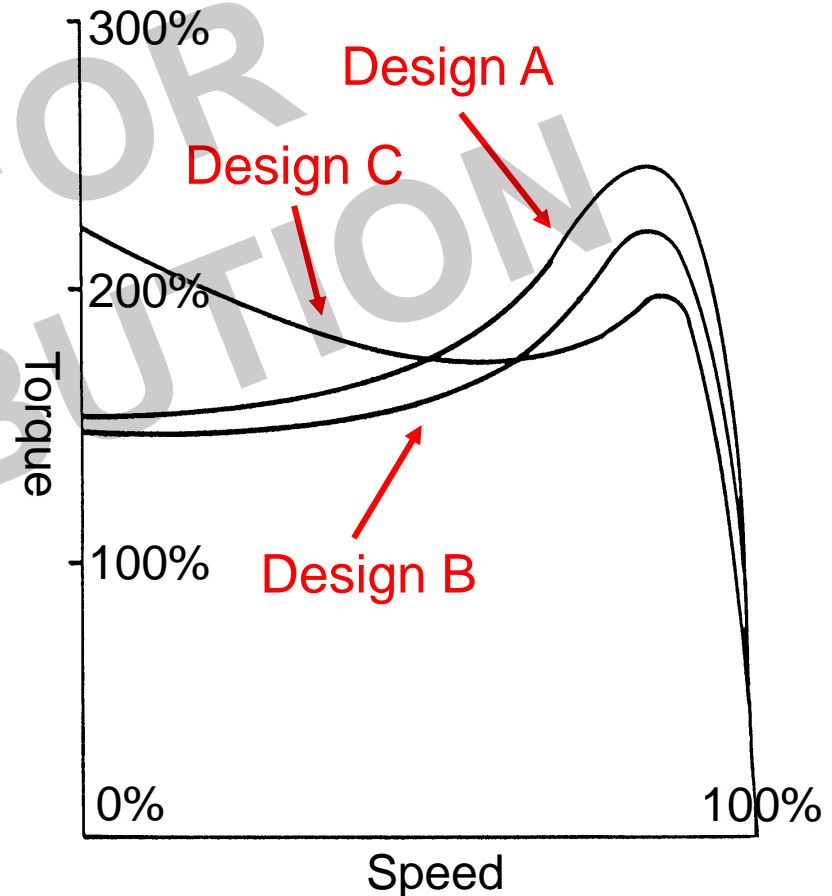

Induction Motors



NEMA D Design

- Very high locked rotor (starting) torque (250 - 300%)
- High breakdown torque (250 - 300%)
- Normal starting current (600 – 700%)
- High full load slip (5 – 10%)
- Low efficiency
- Used in applications that require:
 - Very high breakaway (starting) torque
- Typical loads:
 - Punch presses
 - Elevators
 - Extractors
 - Oil-well pumping

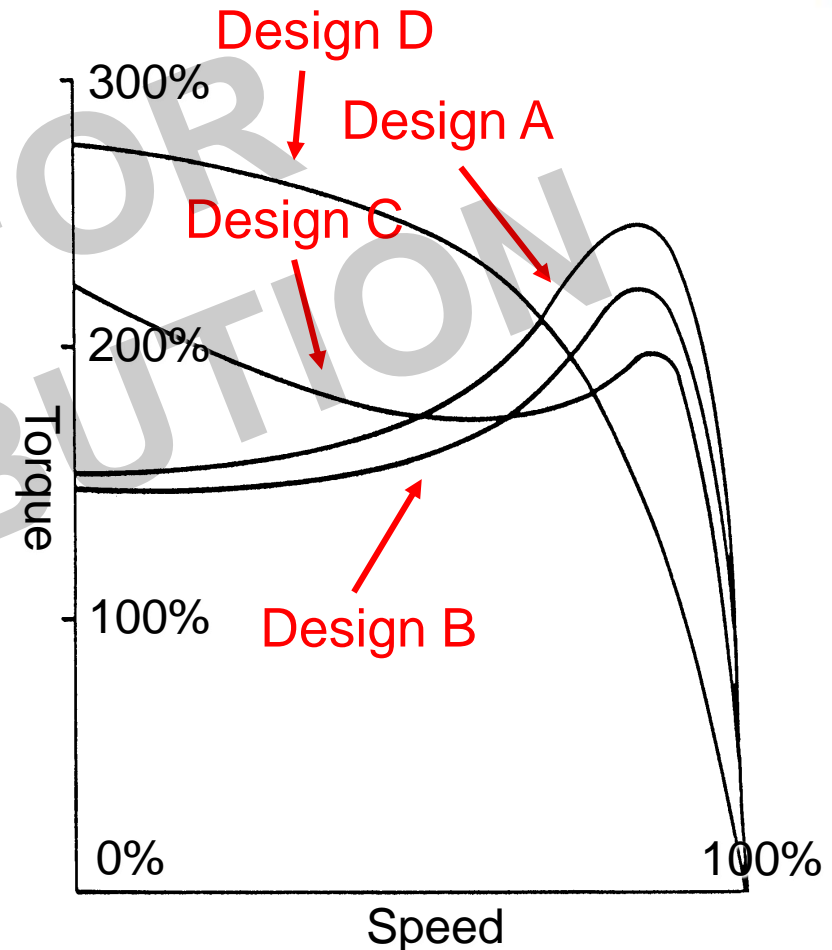

Service Factor

- NEMA defines service factor as a multiplier, when applied to the rated horsepower, indicates a permissible horsepower loading, which may be carried under the conditions specified for the service factor at rated voltage and frequency.
- Service factor can be used for
 - To accommodate inaccuracy in predicting intermittent system power needs.
 - To lengthen insulation life by lowering the winding temperature at rated load.
 - To handle intermittent or occasional overloads.
 - To allow occasionally for ambient above 40°C.
 - To compensate for low or unbalanced supply voltages.
- The service factor was established for operation at rated voltage, frequency, ambient and sea level conditions.
- Do not rely on the service factor capability to carry the load on a continuous basis.

Induction Motors



Insulation Class & Temperature Rise

- TEMPERATURE KILLS MOTORS!
- Rule of thumb: for every 10°C, that the motor temperature exceeds its rated insulation temperature, the insulation life is reduced by half, likewise for every 10°C cooler, the insulation life is doubled.
- NEMA specifies letter designations for motor insulation temperature ratings and allowable temperature rises for motors at full load (and at service factor, if applicable).

NEMA Motor Insulation Temperature Ratings		Temperature Rises			
		1.0SF Motors			1.15SF Motors
Class	Temp.	Ambient	Hotspots	Rise@1.0	Rise@1.15
A	105	+40	+5	60	70
B	130	+40	+10	80	90
F	155	+40	+10	105	115
H	180	+40	+15	125	not defined

Induction Motors

Volts per Hertz (V/Hz) Rating

- The impedance of the motor will change because of the variable frequency due to the inductances.
- At low frequencies the impedance approaches zero making the circuit appear to as a short circuit
- Voltage AND frequency must be changed proportionally.

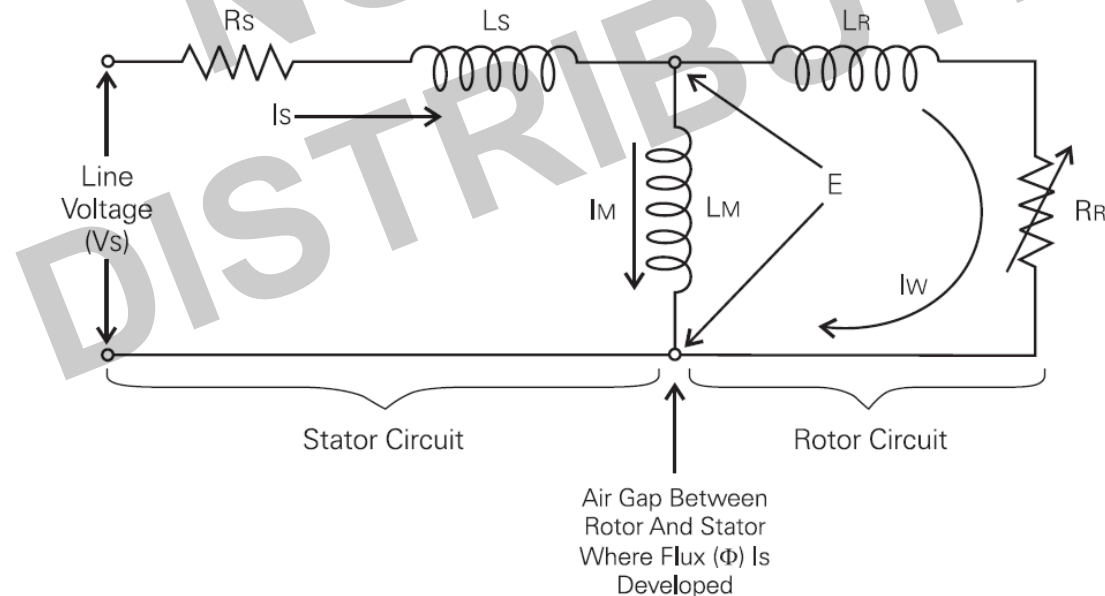

Induction Motors



Volts per Hertz (V/Hz) Rating

- Every motor is designed for a specific V/Hz ratio.
- The rating is defined by the magnetics material used in motor construction.
- The ratio defines the amount of flux in magnetics.
- Operating a motor at higher V/Hz than rated, causes over-flux, magnetics oversaturation, heat and eventually failure.
- Operating a motor at lower V/Hz than rated, reduces flux, significantly reduces torque capability and greatly affects the motor's ability to handle a given load.

$$T = \Phi^2$$

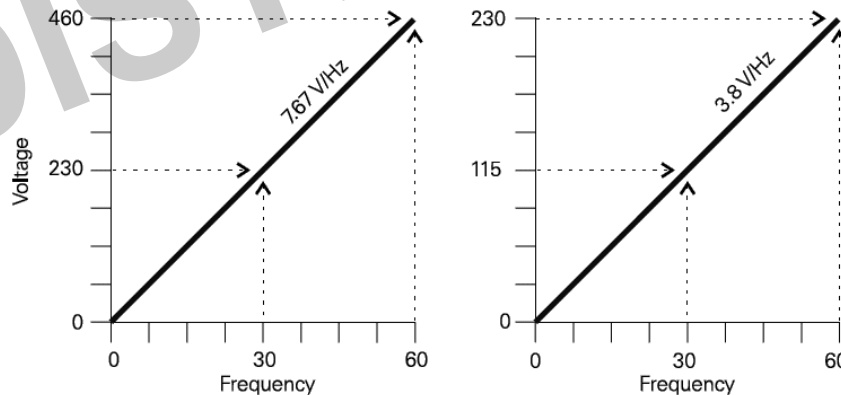

Induction Motors



Main Challenges

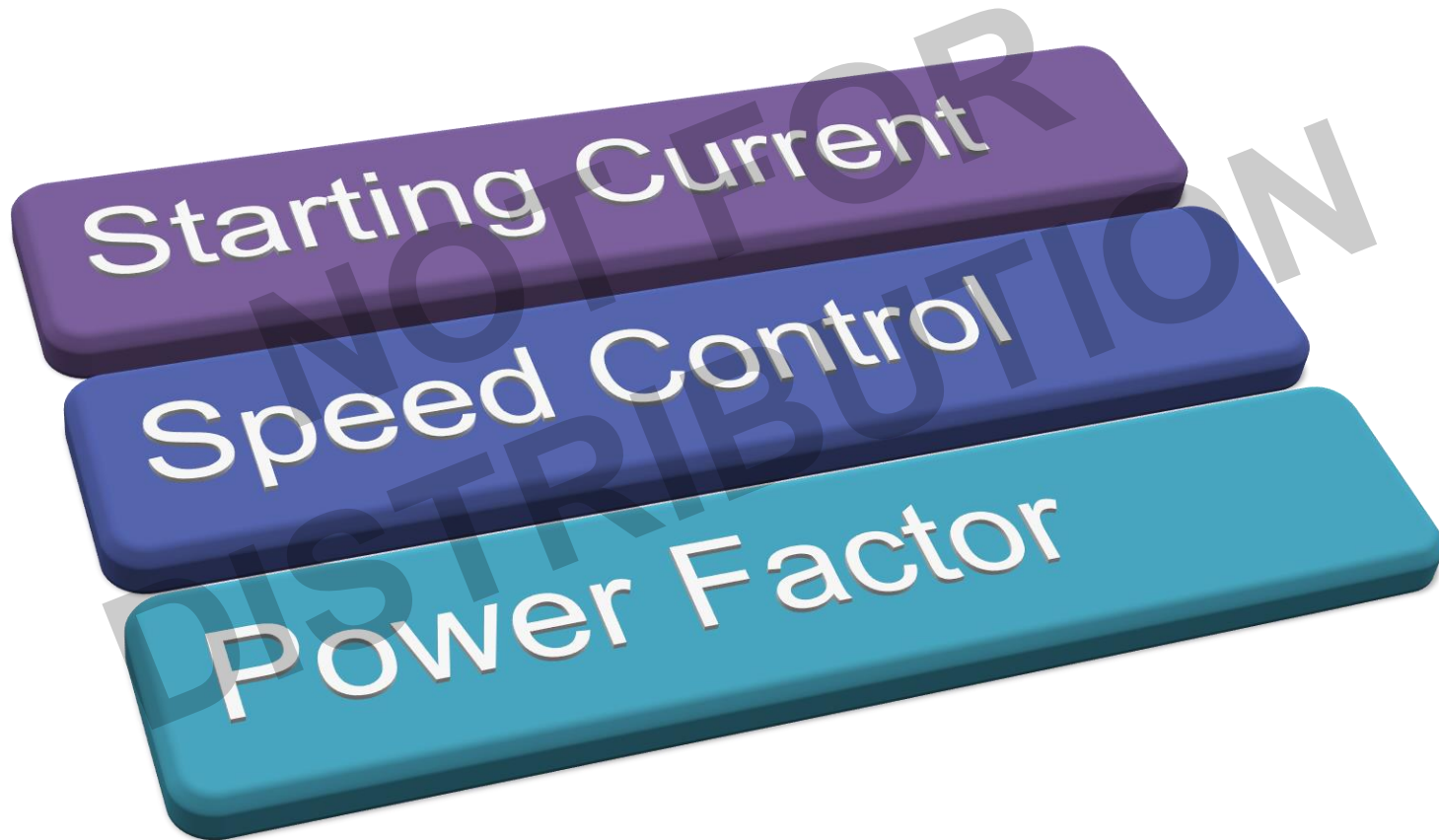

Induction Motors



Main Challenges

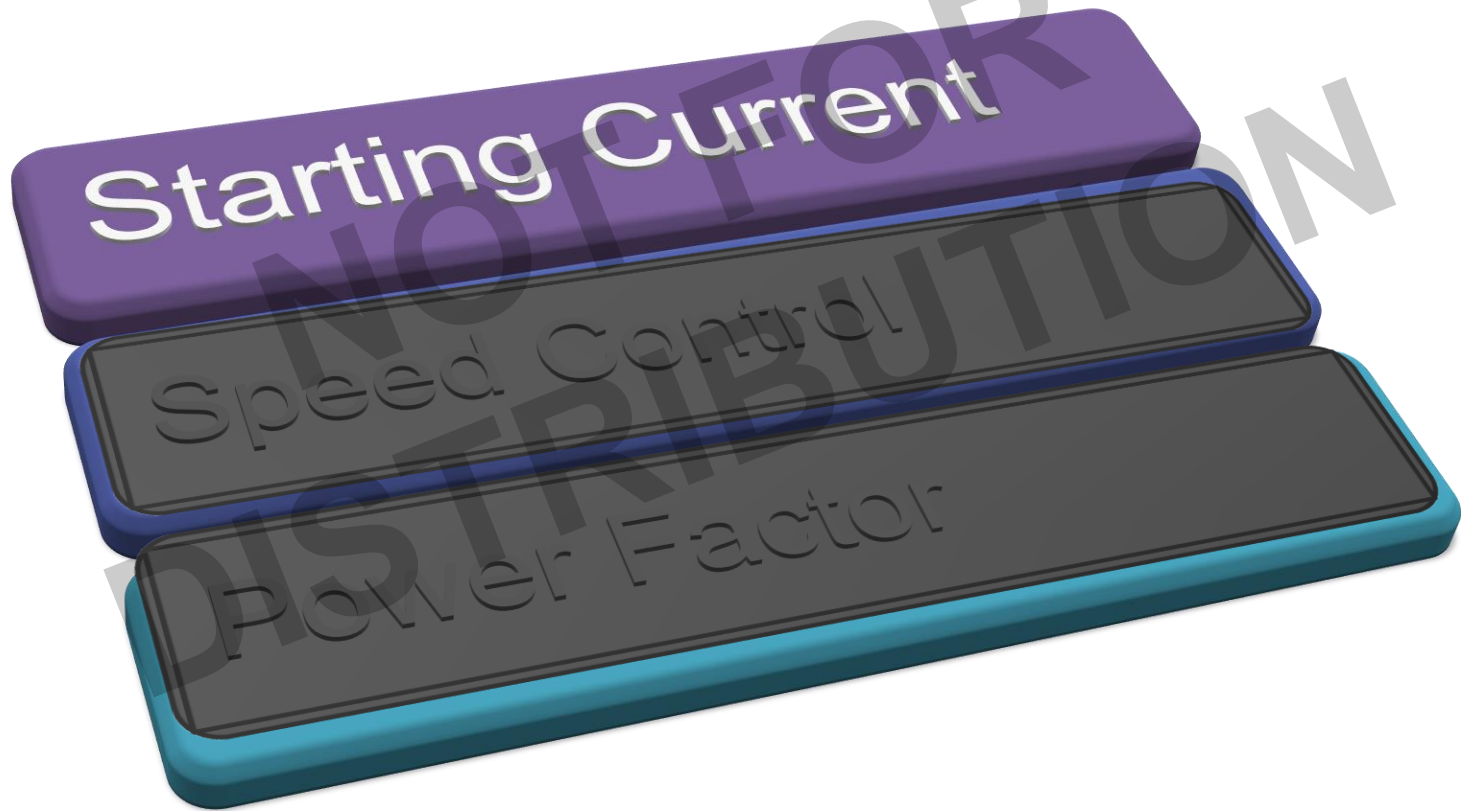

Induction Motors

Motor Starting – Basics

- Current – Speed profile for an induction motor is dramatic for across the line starts at full voltage.
- The starting current is 500 – 900% of the nominal current.
- The starting current significantly stresses the power system.
- The motor produces maximum torque in less than 3 seconds while the majority of applications require less than half the amount of torque to accelerate the connected load.
- This excess amount of torque can create premature mechanical and electrical failures in the drive train of the application.

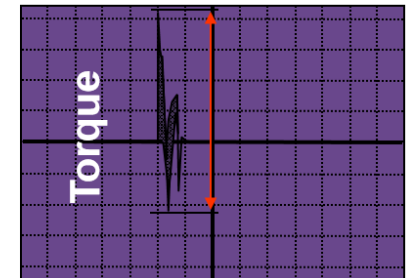
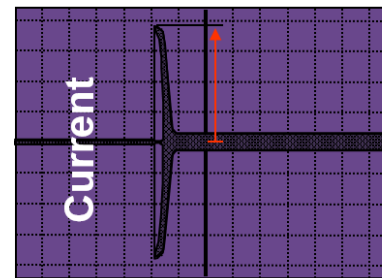
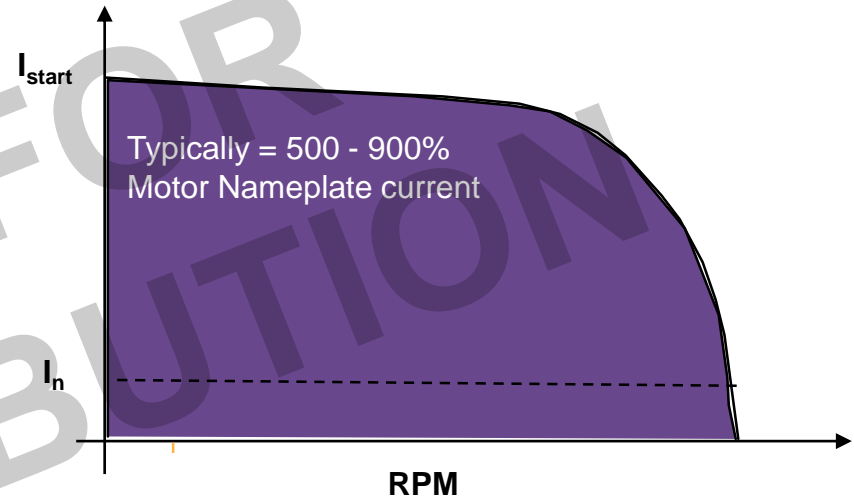

Starting Induction Motors

Starting Methods – Across the Line (ATL) or Direct On Line (DON)

- Simplest method by closing a contactor
- Compact and inexpensive
- Inrush currents typically 500 – 900% of FLA lasting for several seconds
- Mechanical stress on motor windings (damages cable insulation)
- Mechanical stress on drive train (damages motor shaft, belts, gearbox)
- Electrical stress on power system
 - High current
 - Voltage drop

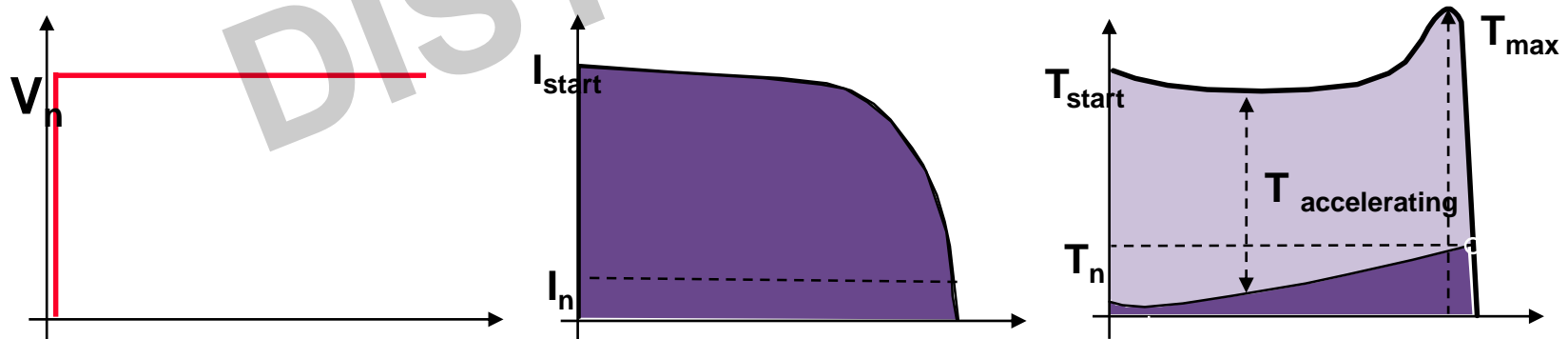

Starting Induction Motors

Starting Methods – Electro Mechanical Reduced Voltage (E-M RV)

- Reduced starting current with current spike during transition to full voltage
- Autotransformer Reduced Voltage Starting
 - A transformer configured with multiple taps and contactors
 - Typically 50%, 65% and 80% taps
 - Large, expensive, high maintenance cost
- Star Delta (Wye-Delta) Starting
 - Winding terminals are brought out and equipped with multiple contactors
 - Reduces current and torque to 33% (one third).
 - Expensive motor, high maintenance cost

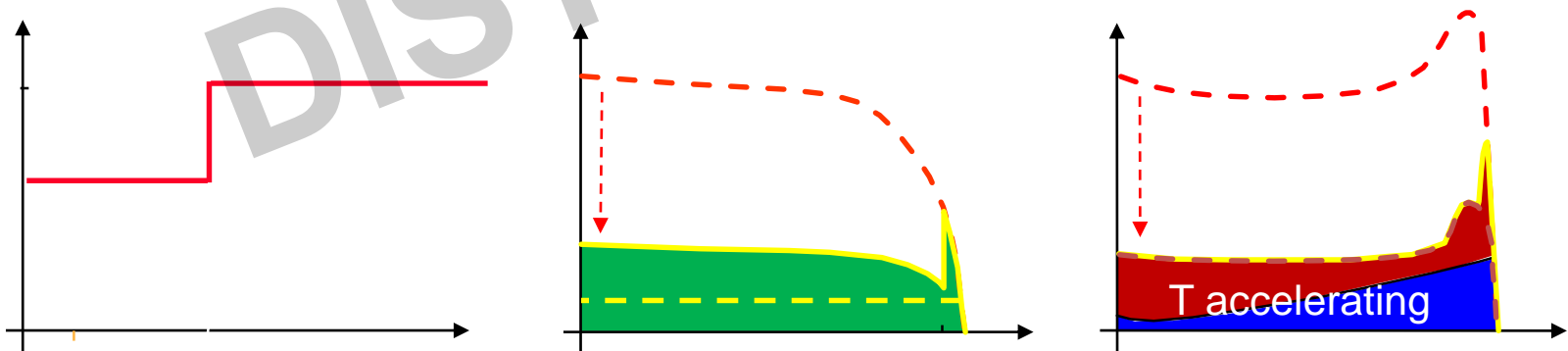

Starting Induction Motors

Starting Methods – Solid State Reduced Voltage (SS RV)

- Soft starters with no current spike
- SCR based full bridge power stacks
- Controlled switching of SCRs to gradually increase the voltage
- Maximum current setting
- Best starting performance among starters
 - Known as Soft Starters
- Starting current limited to minimum 200%

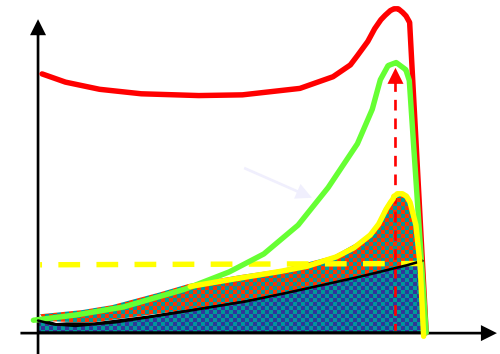
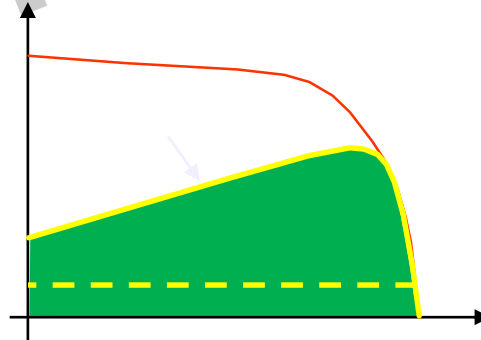
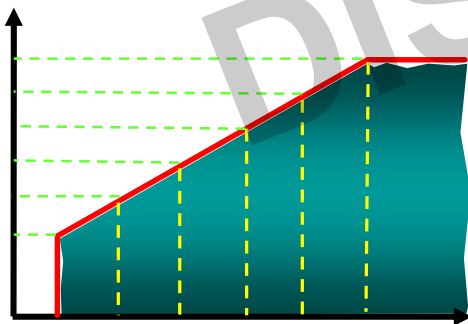
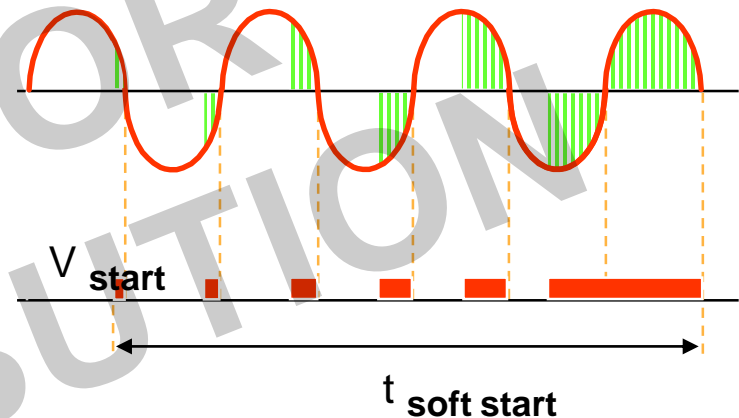

Starting Induction Motors

Starting Methods – Comparison

ATL Start

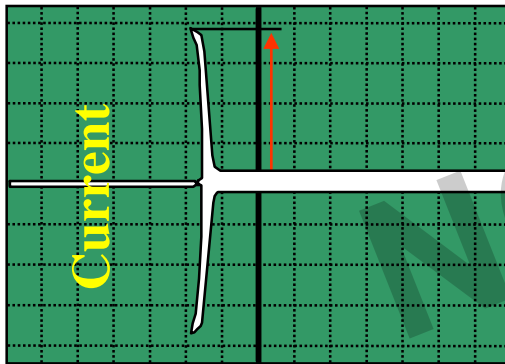

E-M Start

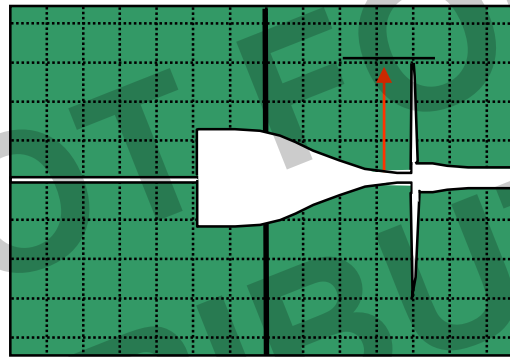

Soft Start

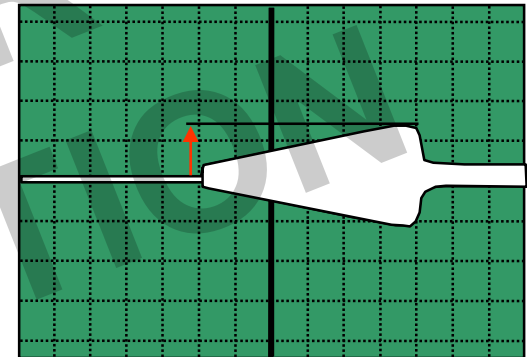

Torque

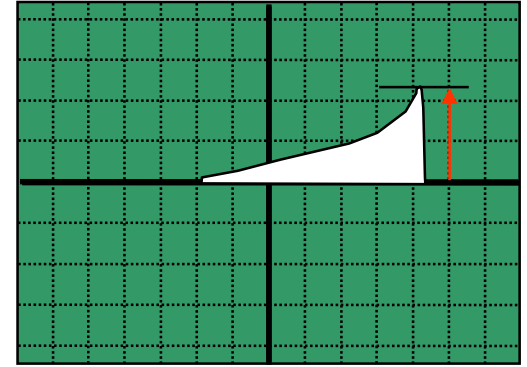
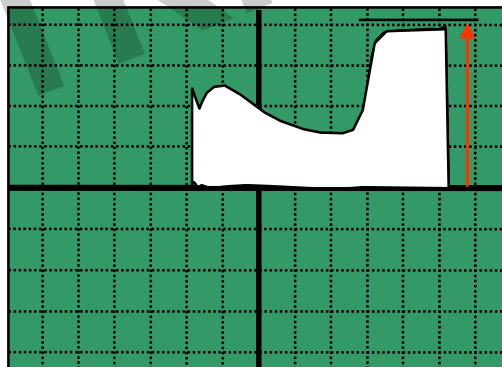
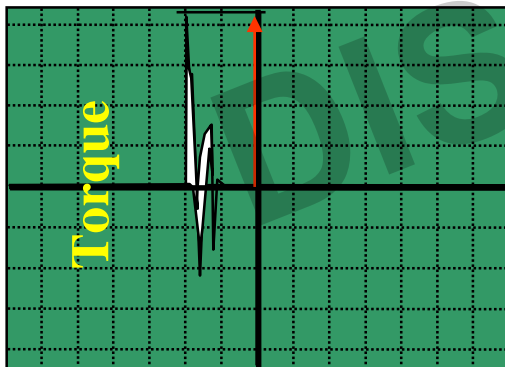

Starting Induction Motors



Solid State Starters – Benefits

- Electrical benefits:
 - Reduced starting current
 - Reduced supply line voltage drop
 - Prevent branch circuit protection nuisance trips
- Mechanical benefits:
 - Reduced mechanical shock to motor, drive train, and connected load
 - Reduced transient forces on conveyor belts and chains
- Process benefits:
 - Increased reliability
 - Maintenance jog for inspections
 - DC injection braking
 - Various start / stop modes
 - Various communication methods

Induction Motors



Main Challenges



Speed Control – Basics

- Induction motor speed is fixed (not constant).
- Motor speed is very close to the synchronous speed.
- Synchronous speed is the rotating speed of the stator's magnetic field which is a function of the frequency of supply to stator and the number of poles in the motor.

$$n_s = \frac{120 * f}{P}$$

- Traditionally, whenever process control needed, additional mechanical systems were used.
 - If flow control required, dampers or valves needed.
 - If speed control required, brakes needed.
- Mechanical process control systems are not reliable and waste energy.

Induction Motors



Main Challenges

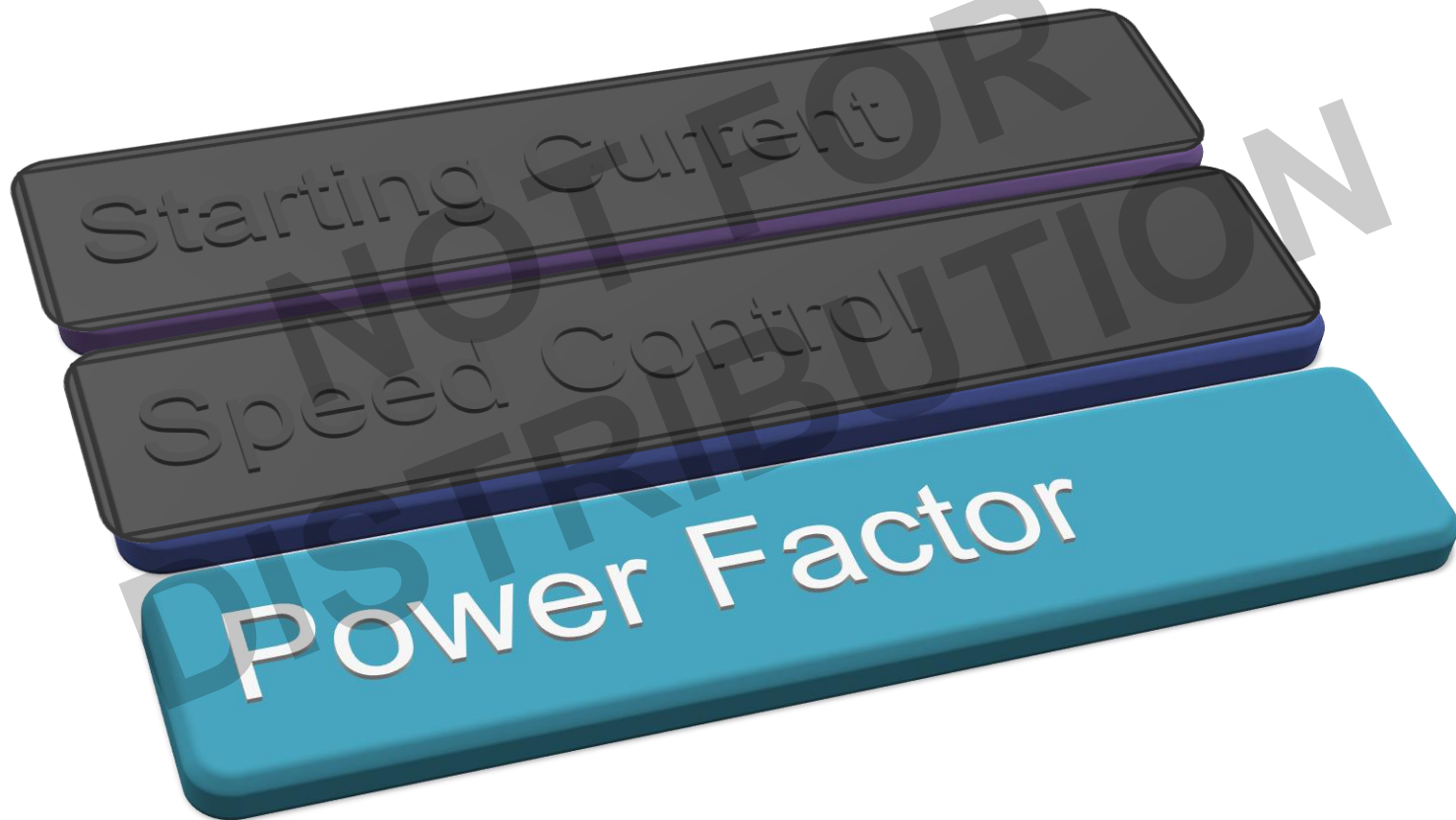

Induction Motors

Power Factor – Basics

- Induction motor input power factor is low.
 - Typically in a range of 0.80 – 0.92.
- Power Factor Correction Capacitors (PFCCs) required to improve PF.

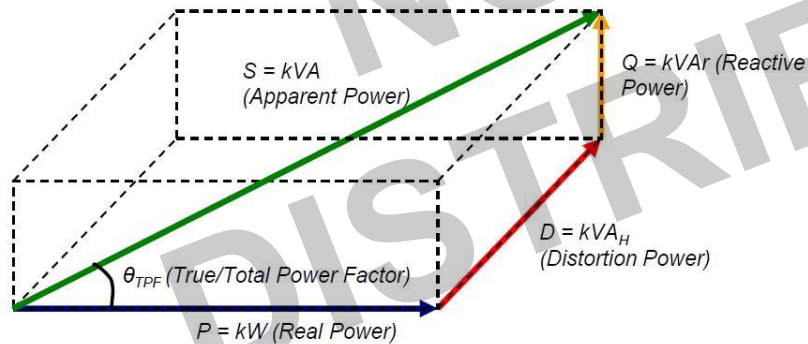

$$kVA = \sqrt{kW^2 + kVAr^2 + kVAH^2}$$

$$PF = \frac{kW}{kVA} = \cos \phi_{TPF}$$

$$PF = DPF * DF \quad (DF \leq 1)$$

Main Challenges – Summary

- Reduced Voltage Solid State Soft Starters improve starting performance of induction motors but they have limitations:
 - Starting current can only be limited to minimum 200%.
 - Voltage drop, although reduced, can be significant based on application requirements.
- Mechanical process control systems such as valves, dampers and brakes provide process control but:
 - They waste energy.
 - They have high maintenance cost.
 - They reduce system reliability.
- Power Factor Correction Capacitors can help improving power factor but:
 - They cause transient issues.
 - They cause resonant issues.
 - They reduce system reliability.



Variable Frequency Drives - General

Variable Frequency Drives



Fundamentals of VFDs

- Variable frequency drives control the speed of AC motors by controlling the frequency of voltages and currents supplied to the motor.
- Each VFD has three main sections:
 - Rectifier: takes the fixed frequency and magnitude voltage sine wave from the grid and rectifies it into almost DC waveforms.
 - Filter: Takes almost DC waveforms from rectifier and provides very DC waveforms to inverter.
 - Inverter: The filtered DC power is sent through a set of switches. These switches by opening and closing at certain speeds and durations can invert DC and recreate output currents and voltages waveforms that mimic sinusoidal AC waveforms.
- The output waveforms are known as Pulse Width Modulation waveforms because they are created by multiple pulses of the switches at short intervals.
- The magnitude and frequency of PWM waveforms are adjustable.

Variable Frequency Drives

Fundamentals of VFDs

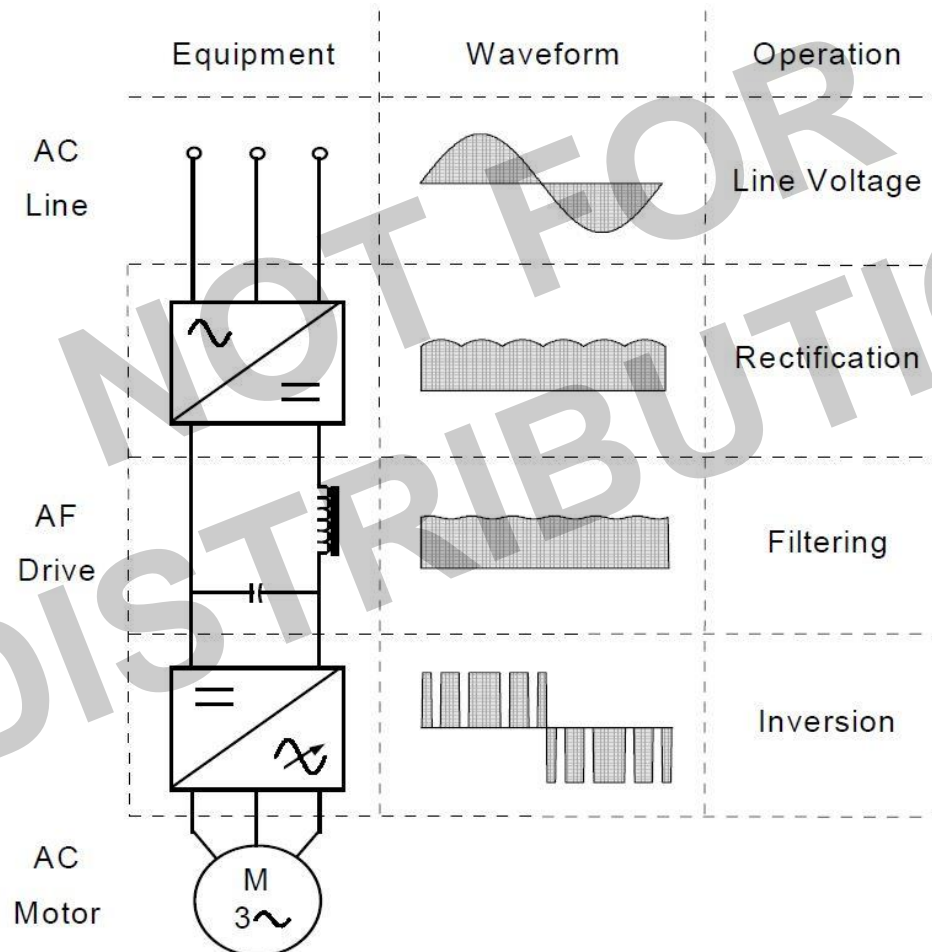

Variable Frequency Drives

Benefits – Starting on VFD

- Torque – Speed curve shifts to left at lower output frequencies.
- Higher starting torque is available at lower frequencies.
- VFD can reduce the starting current without affecting the available starting torque.

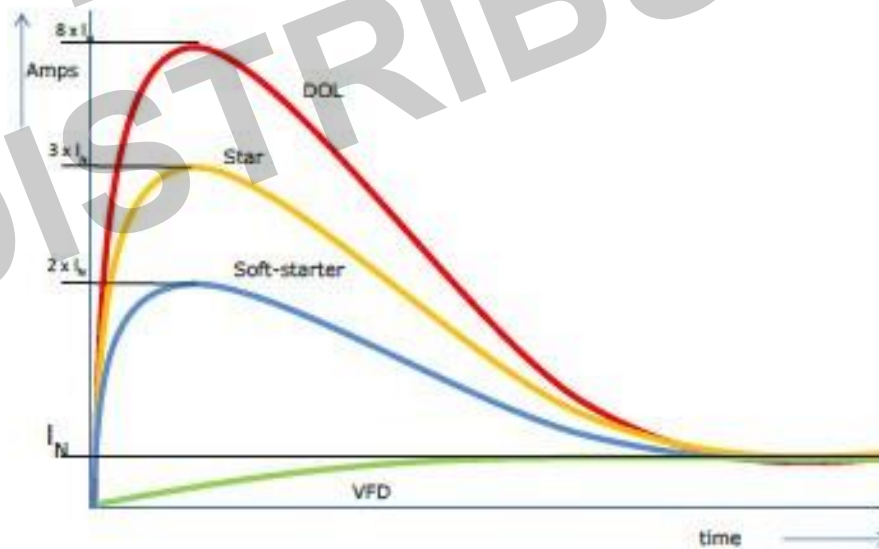
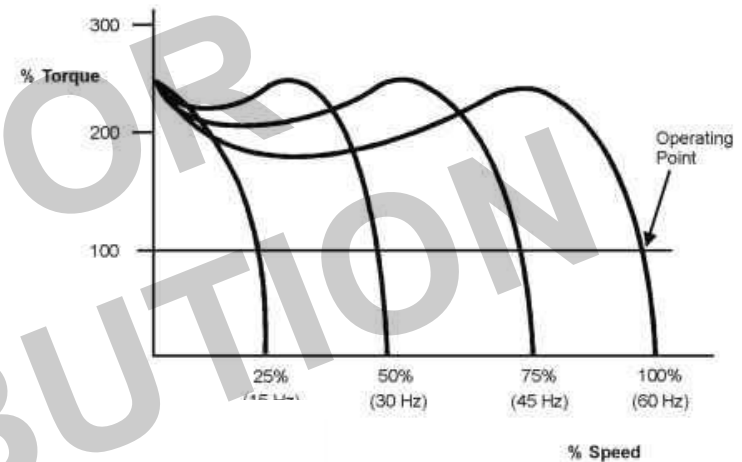

Variable Frequency Drives

Benefits – Speed Control or Process Control

- With VFDs, electrical process control is possible.
 - No need for mechanical systems such as valves, dampers or brakes to control process.
- With VFDs, flow, pressure or speed control is reached by motor's speed control.
- With VFDs, motor generates only enough energy to power the load.

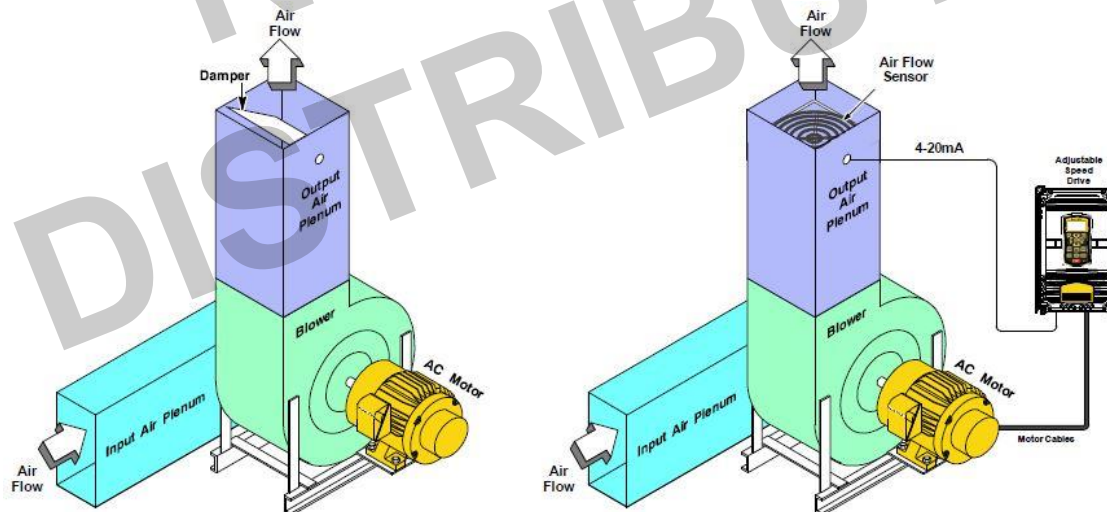

Variable Frequency Drives



Benefits – Energy Saving (Affinity Laws)

- VFDs offer the greatest energy savings for fans and pumps.
- Example: If 80% flow required from a fan, the fan should operate at 80% full speed. The required power is almost 50%.
- The ROI is around 6 – 12 months.

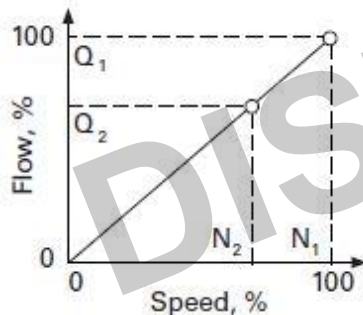

N = Speed
Q = Flow

$$\frac{Q_2}{Q_1} = \frac{N_2}{N_1}$$

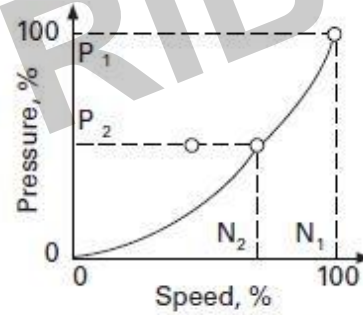

N = Speed
P = Pressure

$$\frac{P_2}{P_1} = \left(\frac{N_2}{N_1}\right)^2$$

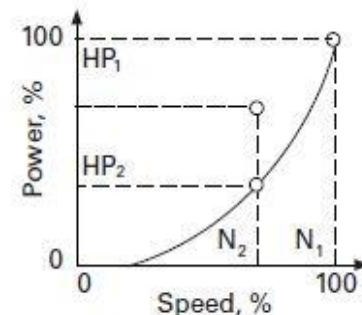

N = Speed
HP = Horsepower

$$\frac{HP_2}{HP_1} = \left(\frac{N_2}{N_1}\right)^3$$

Variable Frequency Drives

Benefits – PF of Motors DOL vs. VFDs on line

- VFDs improve the DPF due to the operation of rectifiers.
- VFDs worsen the DF due to the added harmonics.
- VFDs can improve PF.
- Typical requirement: $PF > 0.95$

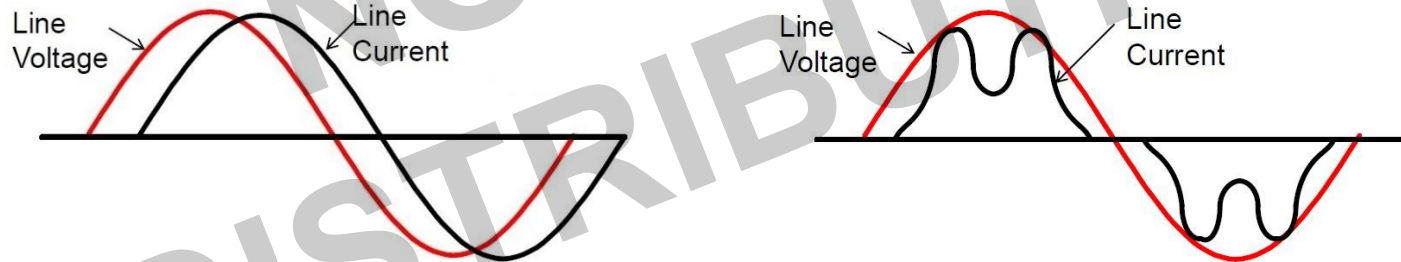

Motor direct on line

Typical DPF = 0.8 ~ 0.92

Typical DF = ~0.99

Typical PF = 0.8 ~ 0.92

VFD on line

Typical DPF = 0.95 ~ 0.999

Typical DF = 0.90 ~ 0.999

Typical PF = 0.85 ~ 0.999

Variable Frequency Drives



Benefits – More Benefits

- Advanced functionality and monitoring
 - Integrated drive – application process control
 - Monitoring motor current, voltage, temperature, and speed
- Advanced protection features
 - Motor short-circuit protection
 - Motor ground fault protection
 - Motor thermal protection
- System Reliability
 - Less mechanical stress caused by valves, dampers, throttles, brakes, ...
 - Reduced number of mechanical components

Variable Frequency Drives

Main Components – LV VFDs

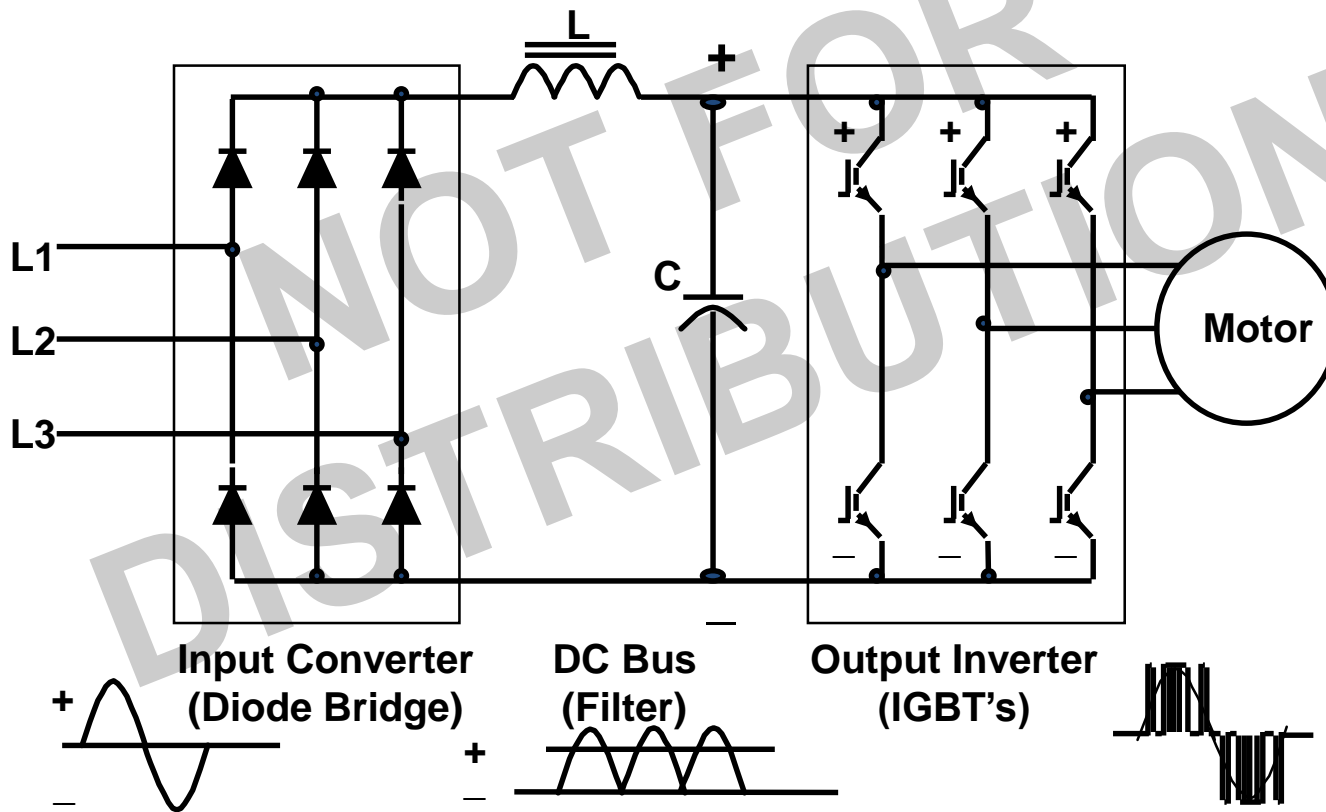

Variable Frequency Drives

Main Components – MV VFDs

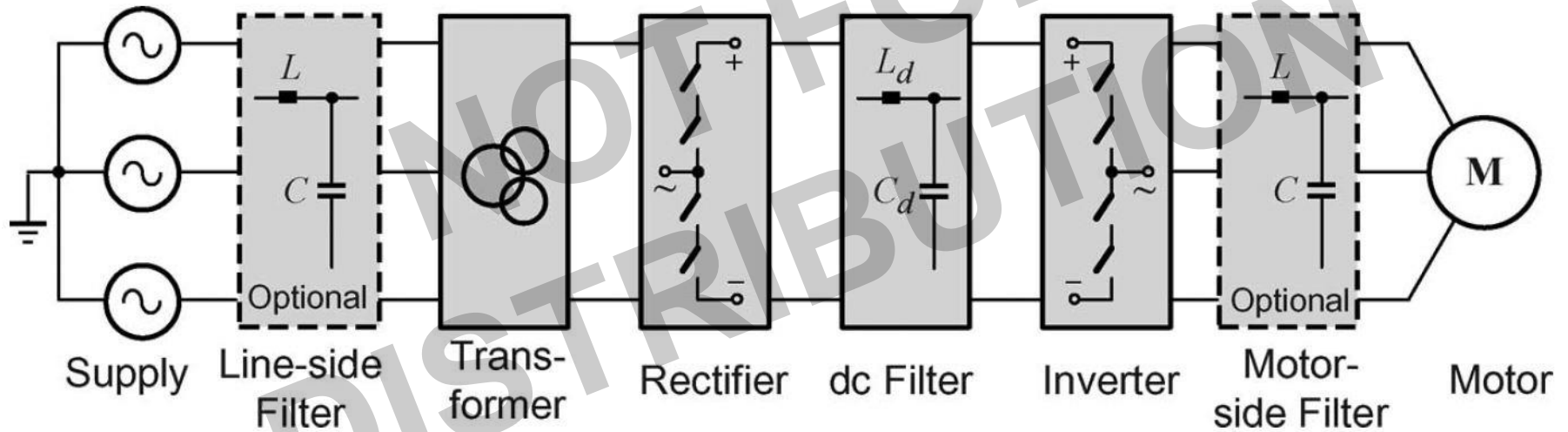

Variable Frequency Drives



Rectifiers – Fundamentals

- Rectifier utilizes power switches to rectify AC waveforms and produce DC voltage and current at its output terminals.
- There two major types of rectifiers:
 - Diode Front End (DFE): Utilizes Diodes as power switches. There is no gate-controlled switching.
 - Active Front End (AFE): Utilizes gate-controlled power switches similar to inverters.
- Rectifier defines the performance of the VFD as far as the input power quality is concerned.
 - IEEE 519 applies to the input power quality of the VFD.
- Rectifiers can have various topologies, especially in MV applications.

Variable Frequency Drives

Rectifiers – Fundamentals

- 6 pulse diode rectifier is the simplest three-phase rectifier.
- Mostly popular in LV applications.
- Requires input filter to meet IEEE 519.

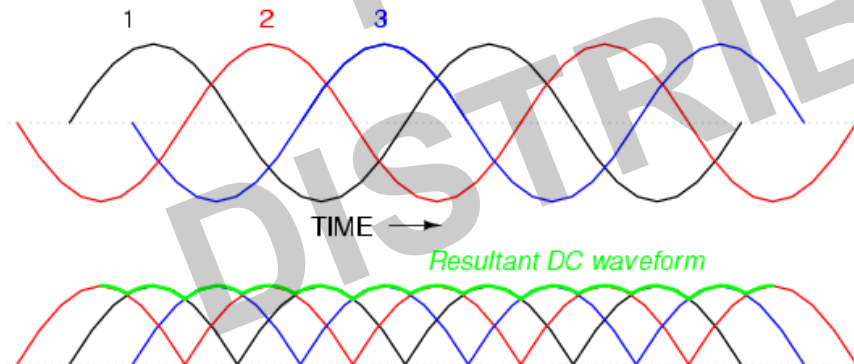
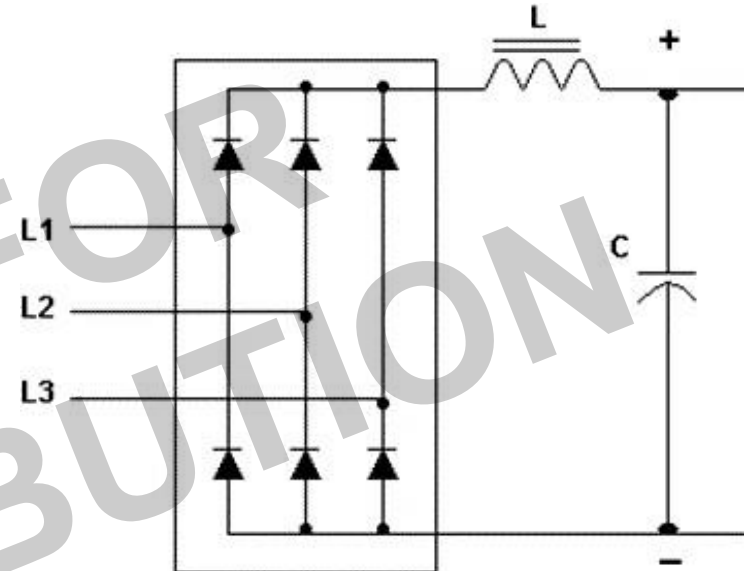

Variable Frequency Drives

Rectifiers – Various Topologies

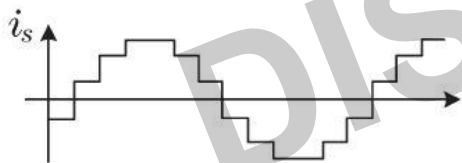
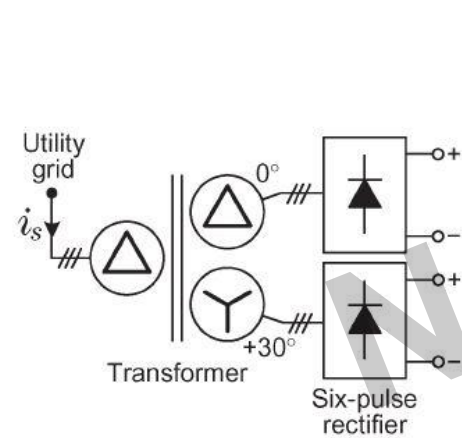

12-pulse Rectifier

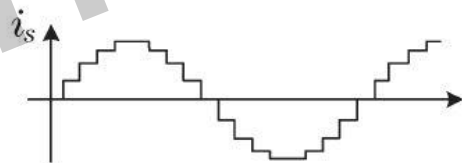
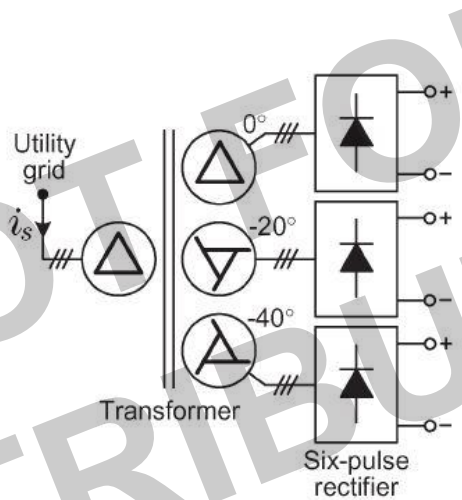

18-pulse Rectifier

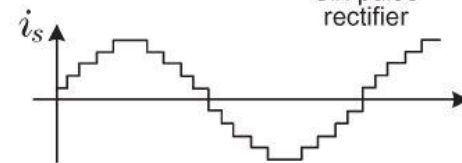
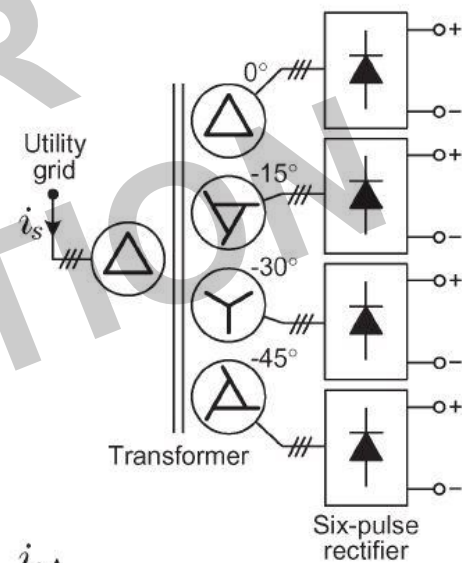

24-pulse Rectifier

Variable Frequency Drives



Inverters – Fundamentals

- Inverter utilizes power switches to synthesize a sinusoidal waveform at its output terminals.
- There are different type of power switches available in industry:
 - Transistors
 - MOSFET (Metal-Oxide Semiconductor Field-Effect Transistor)
 - IGBT (Insulated Gate Bipolar Transistor)
 - Thyristor
 - GTO (Gate Turn-Off Thyristor)
 - IGCT (Integrated Gate-Commutated Thyristor)
 - SGCT (Symmetrical Gate-Commutated Thyristor)
 - IEGT (Injection Enhanced Gate Transistor)
- Inverter defines the performance of the VFD as far as the output waveform quality is concerned.
- Inverters can have various topologies, especially for MV applications.

Variable Frequency Drives

Inverters – Pulse Width Modulation

- Pulse width modulation is used to control the magnitude and frequency of motor supply voltages.
- By varying the time the pulses are on, and which switches are firing, the frequency can be increased or decreased.
- By changing the width and duration of the pulses, the average voltage to the motor can also be increased or decreased.

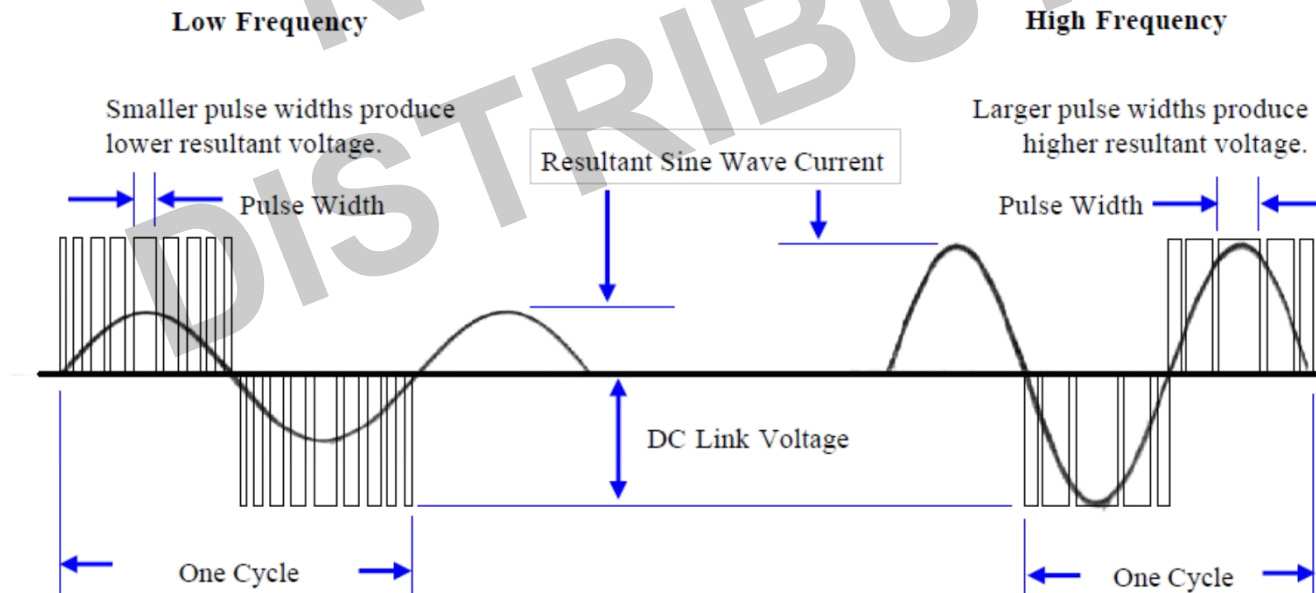

Variable Frequency Drives

Inverters – Various Topologies

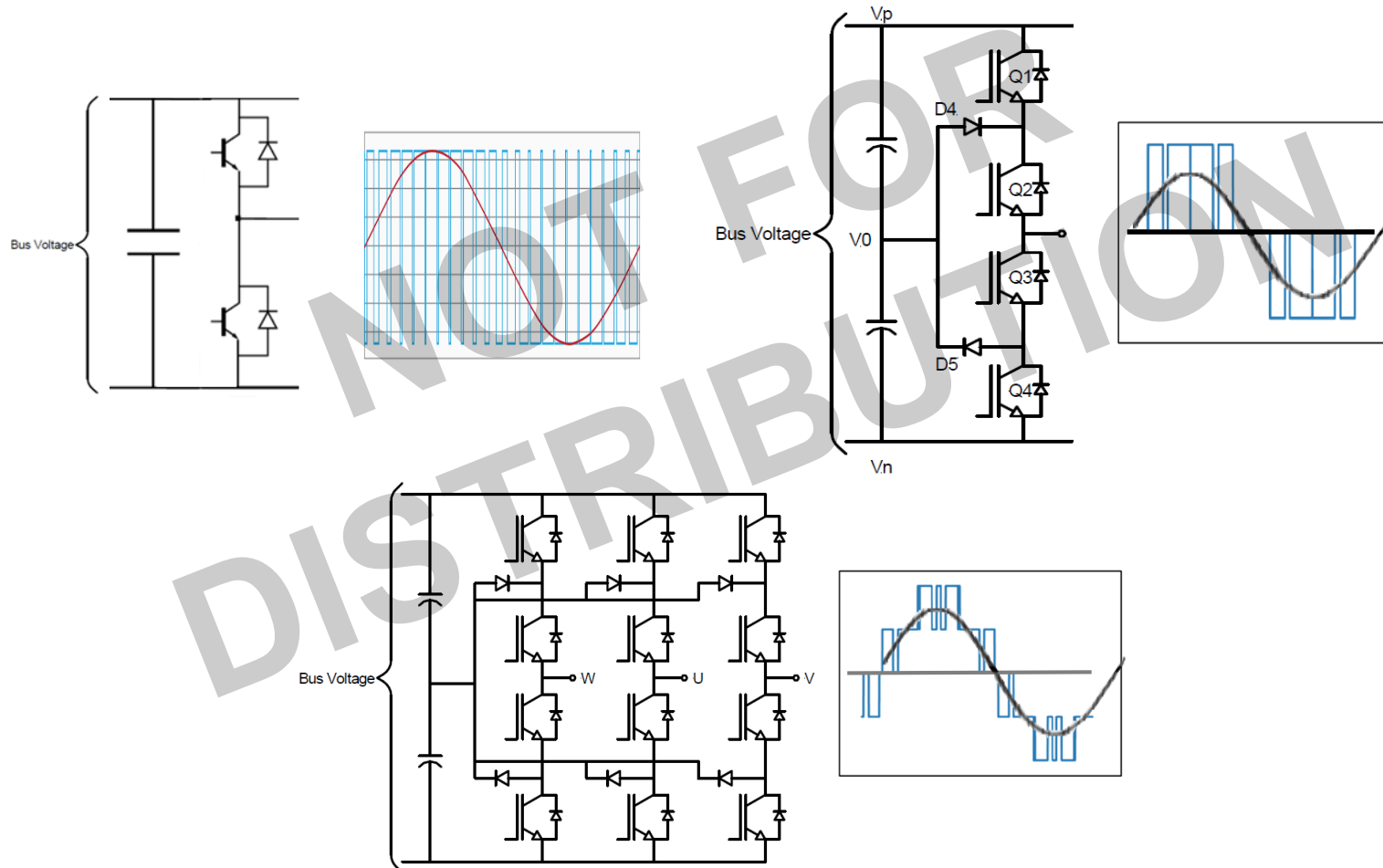

Variable Frequency Drives



Types of Loads – Variable Torque

- Variable Torque: The required torque increases with an increase in speed.
 - The torque requirement increases as the square of the speed.
 - The horsepower requirement increases with the cube of the speed.
 - Most of the loads are this type.
 - VFDs are typically rated for this type of loads.
 - Examples: Fans, Blowers, Centrifugal Pumps, Centrifuges

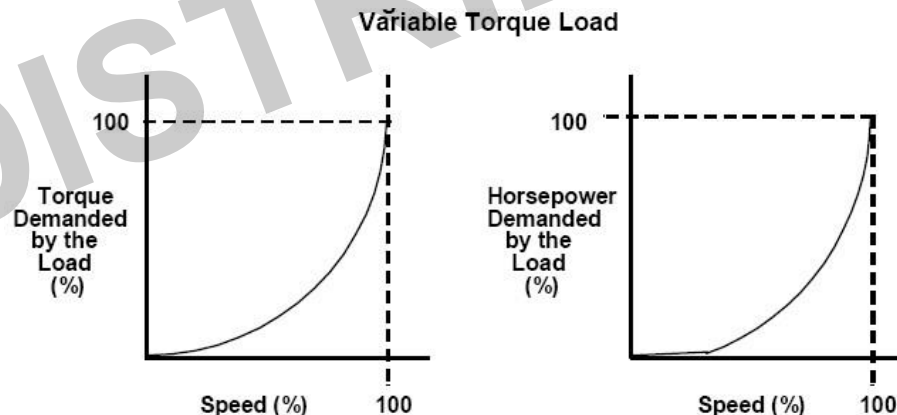

Variable Frequency Drives



Types of Loads – Constant Torque and Constant HP

- Constant Torque: The required torque is relatively same regardless of speed.
 - The horsepower requirements increases linearly with speed.
 - Examples: Friction Loads, Reciprocating Pumps, Conveyors, Lifting Equipment, Rolling Mills, Extruders, High Inertia Loads
- Constant Horsepower: The required torque decreases by the inverse of the increase in speed.
 - The horsepower requirement is constant regardless of speed.
 - Examples: Over-Speed Loads, Winders, Rotary Cutting Equipment, Spindles

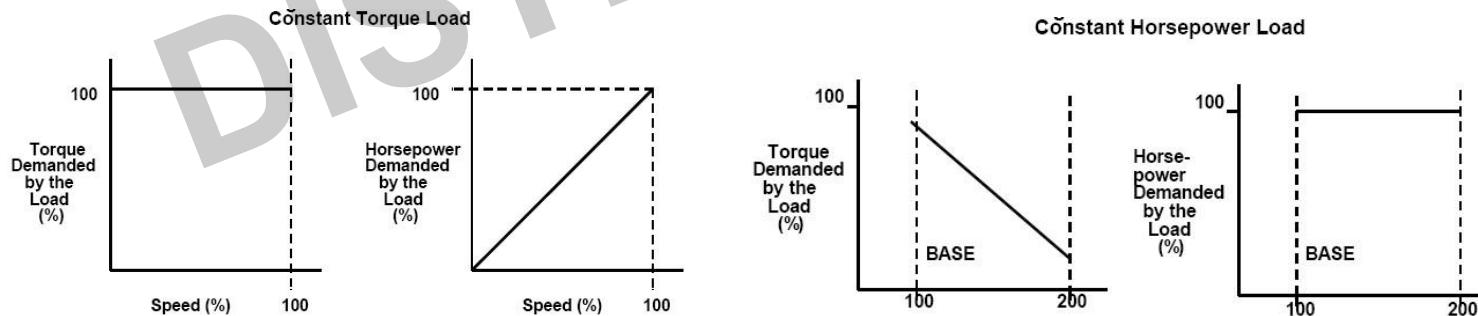

What are harmonics?

Harmonics – Fundamentals

- Whatever the shape, a complex waveform can be split up mathematically into its individual sinusoidal components; One with “fundamental frequency” and the rest with “harmonic frequencies”.
- Fundamental frequency is the lowest or base frequency: f
- Harmonics frequencies are integer multiple of the fundamental frequency:
 $2f, 3f, 4f, 5f$
- Based on phasor rotation of the harmonic with respect to the fundamental phasor:
 - Positive sequence harmonics $(3n+1)f$
 - Negative sequence harmonics $(3n+2)f$
 - Zero sequence harmonics $(3n)f$

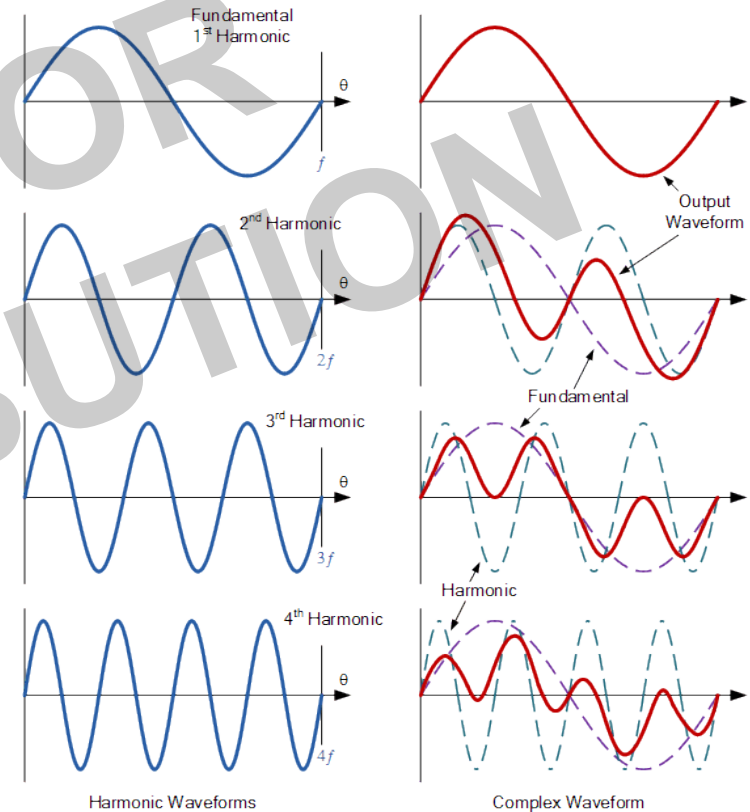

What are harmonics?

Harmonics – Impacts

- Harmonics are generated by non-linear loads.
- Iron-cored inductors, transformers, ballasts in fluorescent lights, and any switching circuit: Switch mode power supplies and VFDs
- Harmonics are measured by THDv and THDi or TDD value.
- “+” sequence harmonics: Overheating of conductors, power lines and transformers due to the addition of the waveforms.
- “-” sequence harmonics: Weaken the rotating magnetic field require by motors, causing them to produce less mechanical torque or torque pulsations.
- “0” sequence harmonics: Circulate between phase and neutral or ground causing heat and common mode voltages.
- Other concerns:
 - Nuisance operation of fuses or circuit breakers
 - Resonance (capacitor banks)

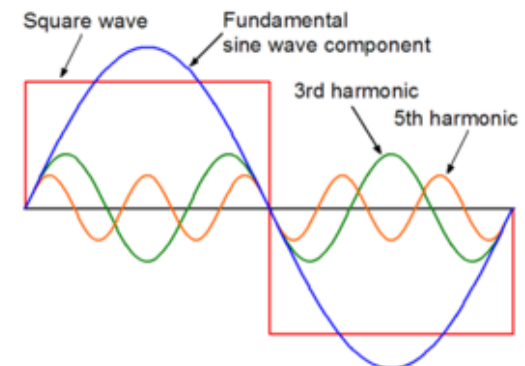

Variable Frequency Drives



Inverters – PWM & Output Harmonics

- PWM generates harmonics on the output waveforms of a VFD.
- Voltage harmonics cause additional Core or Iron losses in motor's magnetic core.
 - Hysteresis losses($\sim f$)
 - Eddy current losses ($\sim f^2$)
- Current harmonics cause additional Conductive or I^2R losses in motor's windings.
- Interaction of Positive and Negative sequence magnetic fields and currents produces torsional oscillations (vibrations) of the motor's shaft. In the worst case conditions, if the frequency of oscillations coincides with the natural mechanical frequency of the shaft, the vibrations are amplified and severe damage to the motor shaft may occur.

Variable Frequency Drives

Inverters – PWM & Output dv/dt

- PWM generates large differential voltage (AKA dv/dt) which is defined by size of steps on the square waveforms (voltage rise) and how fast is switching happening (rise time). It is measured by $V/\mu s$.
- High dv/dt causes the voltage peaks to be unevenly distributed across the motors windings and therefore, stressing the motor windings insulation resulting in discharge (Partial Discharge and Corona), heat and eventually, insulation failure.
- High dv/dt causes reflections in the output cables which consequently limits the distance from VFD output terminal to the motor's input terminals.

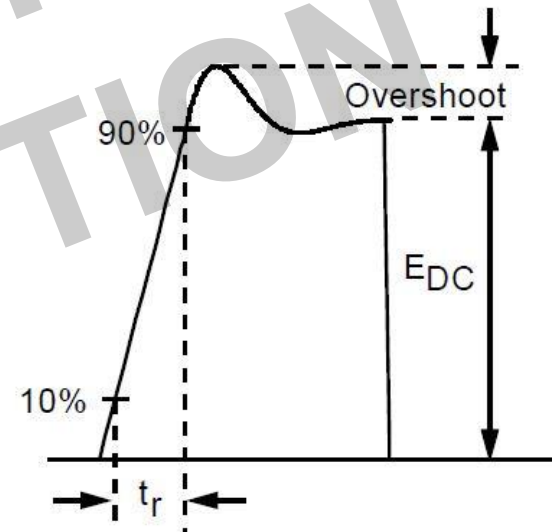

Variable Frequency Drives



Inverters – Output Waveform Quality

- There is no standard defining maximum acceptable values for voltage and current harmonic distortion.
- However, standards do consider the increase of motor losses due to the non-sinusoidal supply.
- NEMA considers a derating factor (torque reduction) to avoid excessive overheating of a general purpose motor fed by a supply with harmonic content using Harmonic Voltage Factor (HVF).

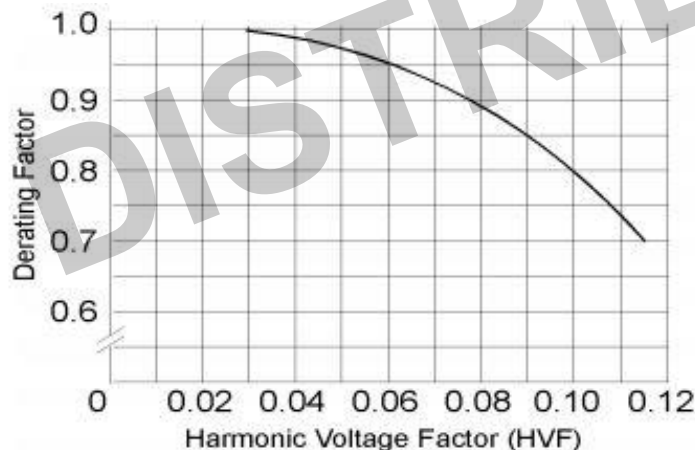

$$HVF = \sqrt{\sum_{h=5}^{\infty} \frac{V_h^2}{h}}$$

Variable Frequency Drives

Output Harmonic Solutions

- Use of “Inverter Duty” motor
 - Insulation systems improved to reduce degradation of motors that are subjected to transient voltage spikes.
 - NEMA requires motor insulation systems for 460 V rated motors to be capable of withstanding 1,600 V peak, at a rise time of 0.1 μ s.
 - These motors can be used without additional filters or load reactors provided that voltage overshoots do not exceed the upper limit at the motor terminals.
 - Use of these motors are more common in LV applications.
 - Impact on cost, size and weight of motor is significant in MV applications.



Variable Frequency Drives



Output Harmonic Solutions

- Increasing switching frequency
 - The harmonic content in the current waveform generated by the PWM process is reduced as the switching frequency increases.
 - Switching losses (heat) are proportional to switching frequency.
 - Switching frequency is limited by type, size and loading of switching module.
 - Typical switching frequency is 1 – 20 kHz in LV inverters.
 - Typical switching frequency is 0.5 – 1 kHz in MV inverters.

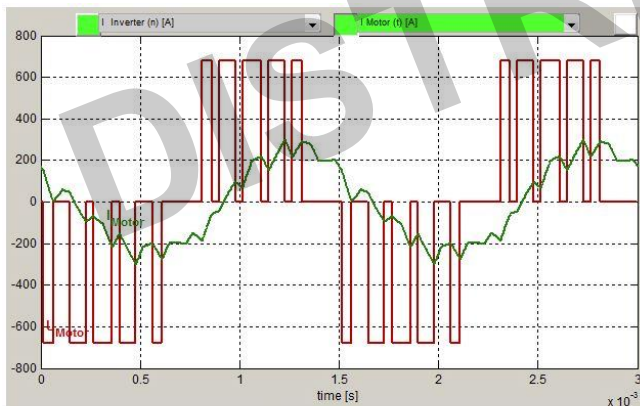

50kW @ 20000rpm, using a 4kHz switching frequency, the THD(i) = 17.27%

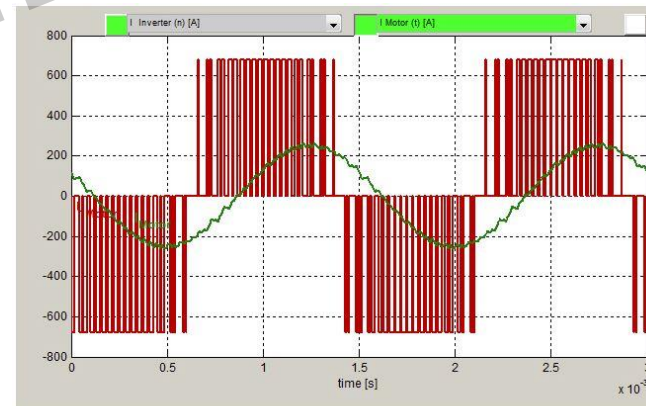

50kW @ 20000rpm, using a 16kHz switching frequency, the THD(i) = 4.05%

Variable Frequency Drives

Output Harmonic Solutions

- Use of output dv/dt filter (RL or RLC circuit)
 - Low pass filter with power resistors.
 - L & C have small values.
 - The cut-off frequency is right above the inverter switching frequency.
 - Used in MV and LV applications.
 - Filters the output current ripples but the voltage is still PWM pattern shaped.

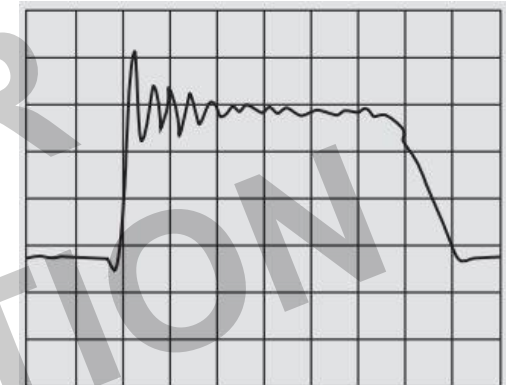
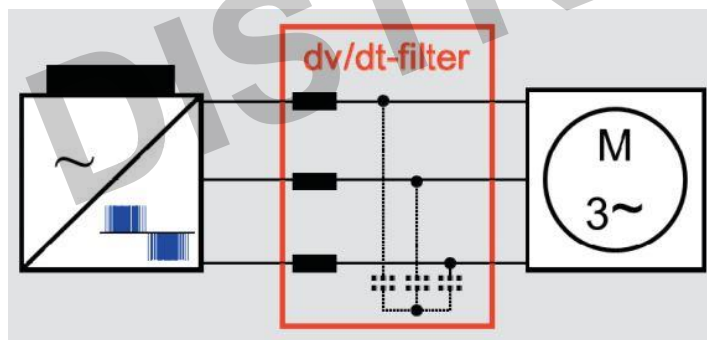

Without dv/dt filter

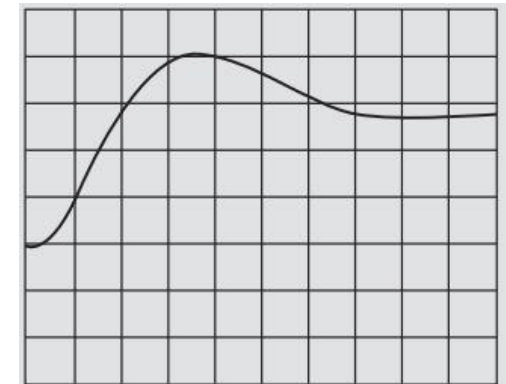

With dv/dt filter

Variable Frequency Drives

Output Harmonic Solutions

- Use of output harmonic filter (L or LC circuit)
 - These filter are also known as sine wave filters.
 - Low pass frequency filters which convert the rectangular PWM pattern shaped waveform into a smooth sine wave voltage.
 - Used in MV and LV applications.
 - Performance is dependent on loading, motor speed and switching frequency.
 - Costly, large footprint, engineering intense solution, separate installation and protection, extra power loss

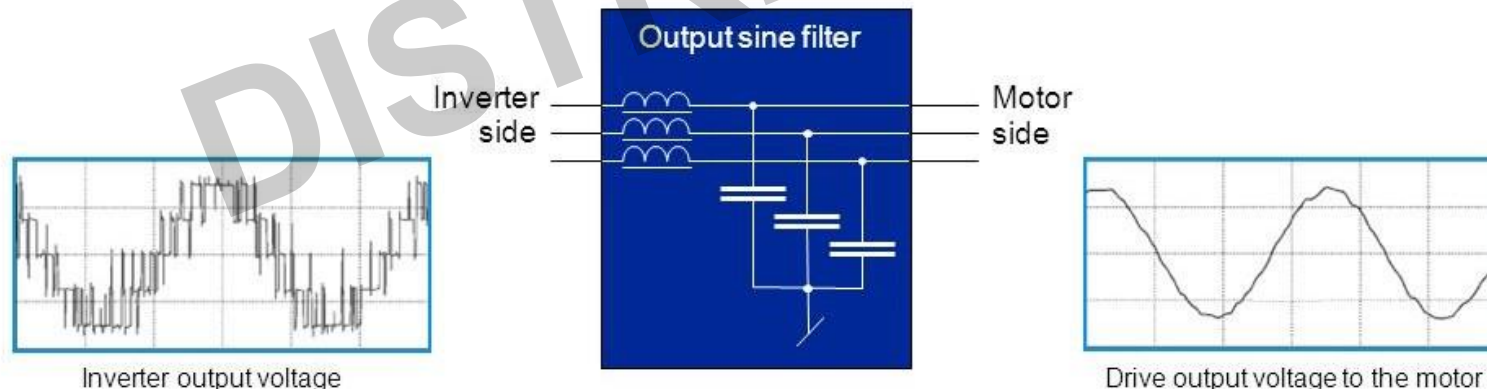

Variable Frequency Drives

Output Harmonic Solutions

- Producing multi-level (motor friendly) waveforms
 - Most effective method of improving output waveform quality
 - HVF, THD_v, THD_i and dv/dt decrease as number of levels on the rectangular PWM waveform increases.
 - For example, a MV inverter with 13-level voltage waveform has HVF less than 1% and may be used with standard design motor with no derating.

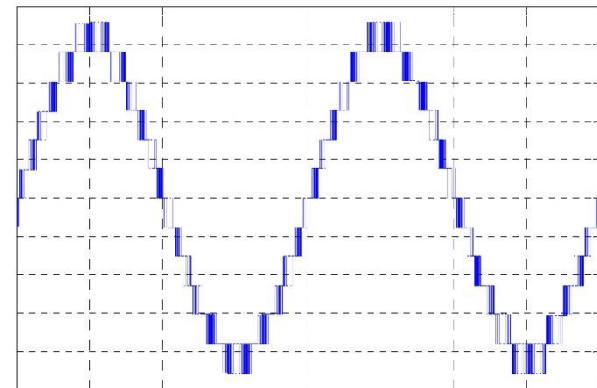
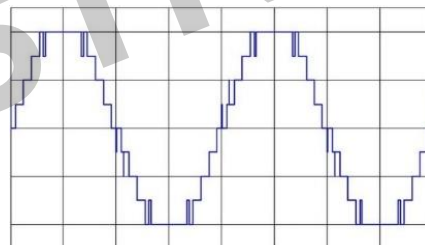
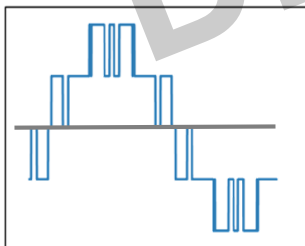
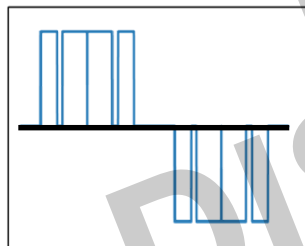

Variable Frequency Drives



Rectifiers – Input Harmonics and IEEE 519

- Recognized industry standard in North America for setting harmonic limits.
- Designed to limit utility harmonics as well as customer harmonic contribution to the utility grid.
- Standard ONLY applies to the Point of Common Coupling (PCC):
 - The point where the utility connects to multiple customers or one big customer.
 - If a utility transformer is provided, the PCC is most likely on the line side of the transformer.
- IEEE 519 sets limits for both voltage distortion and current distortion based on system voltage and short-circuit ratings.
- IEEE 519 is widely misunderstood and misapplied in industry.

Variable Frequency Drives



IEEE 519 – Voltage Distortion Limits

- THD_v: Total Harmonic Voltage Distortion, is a MEASURED distortion on actual instantaneous voltage.
- THD_v is a sinewave quality factor: Lower the % THD_v, the closer the voltage waveform is to a true sinusoidal waveform.
- IEEE 519 sets limits to PF as well.

$$THD_v = \frac{\sqrt{\sum_{h=2}^{\infty} V_h^2}}{V_1} \times 100\%$$

Bus Voltage @ PCC	Individual Harmonic V _h (%)	Total Voltage Distortion THD _v (%)
V ₁ ≤ 69 kV	3.0	5.0
69 kV < V ₁ ≤ 161 kV	1.5	2.5
V ₁ > 161 kV	1.0	1.5

Variable Frequency Drives



IEEE 519 – THDi vs. TDD

- THDi: Total Harmonic Current Distortion, is a MEASURED distortion on actual instantaneous current.
- THDi is a sinewave quality factor: Lower the % THDi, the closer the current waveform is to a true sinusoidal waveform.
- TDD: Total Harmonic Demand Distortion, is a CALCULATED harmonic current distortion against the Full Load current.
- TDD looks at the full capacity of the system for distortion. If non-linear loads are small % of the full load system current demand, the TDD is less.

$$THD_i = \frac{\sqrt{\sum_{h=2}^{\infty} I_h^2}}{I_1} \times 100\% \quad \text{vs.} \quad TDD = \frac{\sqrt{\sum_{h=2}^{\infty} I_h^2}}{I_{FL}} \times 100\%$$

Demand	$I_{1,rms}$	$I_{h,rms}$	$I_{L,rms}$	THDi	TDD
100%	936.00	35.57	936.68	3.8%	3.8%
45%	424.00	21.20	424.53	5.0%	2.3%
12%	111.00	13.32	111.80	12.0%	1.4%

Variable Frequency Drives



IEEE 519 – Current Distortion Limits

- Current distortion limits are dependent on the voltage rating and “stiffness” or “softness” of the source power system.
- Stiffness is defined by the short-circuit ratio (I_{SC}/I_L) of the power system.
- A stiffer source has lower impedance, hence, higher short-circuit ratio.
 - PCC close to power plant
- A softer source has higher impedance, hence, lower short-circuit ratio.
 - PCC far from power plant or a generator

I_{SC} / I_L	$h < 11$	$11 \leq h < 17$	$17 \leq h < 23$	$23 \leq h < 35$	$35 \leq h$	TDD
< 20	4.0	2.0	1.5	0.6	0.3	5.0
$20 < < 50$	7.0	3.5	2.5	1.0	0.5	8.0
$50 < < 100$	10.0	4.5	4.0	1.5	0.7	12.0
$100 < < 1000$	12.0	5.5	5.0	2.0	1.0	15.0
> 1000	15.0	7.0	6.0	2.5	1.4	20.0

Variable Frequency Drives



Input Harmonic Solutions

- Line reactors (3 – 5 %)
 - An inductor shows higher reactance and impedance at higher frequencies.
 - Lowest cost, increased protection for VFD, insensitive to system changes
 - Larger enclosure, moderate reduction in harmonics, possible voltage drop, power loss (heat)
- Isolation Transformer
 - Delta / Wye transformer cancels triplen harmonics
 - Moderate cost, elimination of 3rd, 9th, etc., isolation from ground
 - Large footprint, separate enclosure, moderate reduction in harmonics
- Phase Shifting or Harmonic Mitigating Transformer
 - Special transformer (Delta / multiple ZigZag) that use phase shifting to cancel targeted harmonics
 - Effective harmonic elimination, effective harmonic reduction
 - Engineering intensive solution, load must be balanced between secondary transformers (windings)

Variable Frequency Drives

Input Harmonic Solutions

- Passive Filters (Parallel or Tuned)
 - RLC circuit, connected in parallel with load, tuned to a specific frequency (typically 5th or 7th) that acts as a trap for harmonics.
 - Can target “trouble” or “resonance” harmonics, single filter for multiple drives
 - Costly, engineering intense solution, separate installation and protection, can interact with all non-linear loads (resonance), may cause voltage rise
- Passive Filters (Series and Broadband)
 - LC circuit, connected in series with load, that acts as low pass filter.
 - Effective high frequency harmonic reduction, increased protection for VFD, power factor correction
 - Costly, large footprint, may result in leading PF, possible resonance

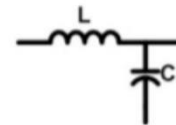
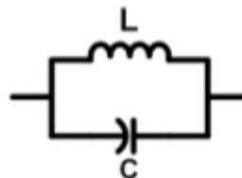

Variable Frequency Drives

Input Harmonic Solutions

- Active Filters
 - Combination of LC and switching circuit that actively senses harmonics and injects equal and opposite currents to cancel harmonic currents.
 - Flexible harmonic control, can be applied within MCC, effective for multiple loads, PF correction
 - Very expensive, very complex, high maintenance

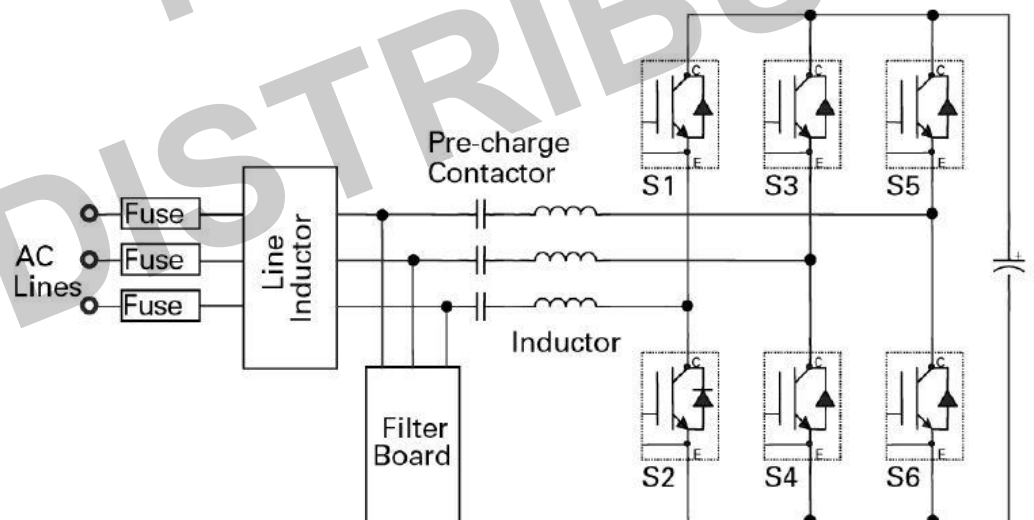

Variable Frequency Drives

Input Harmonic Solutions

- Multi-Pulse Rectifier (12-Pulse, 18-Pulse, 24-Pulse)
 - Combination of phase shifting transformer and multiple rectifiers.
 - Substantial reduction in harmonics, insensitive to system changes
 - Costly, large footprint, design complexity
 - First major harmonics appear at $n \pm 1$.
 - Required phase shift can be calculated as $360^\circ / n$.

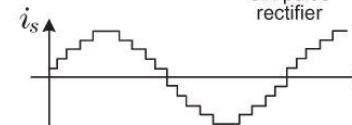
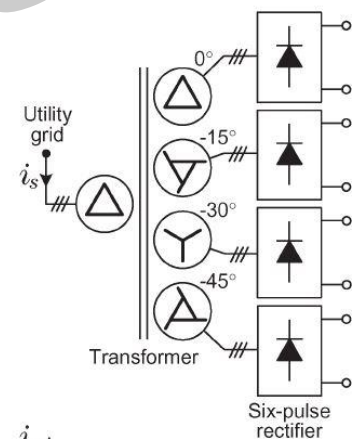
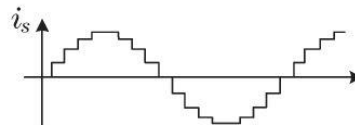
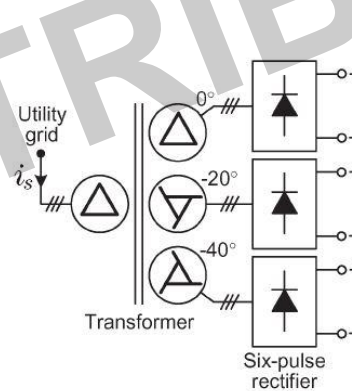
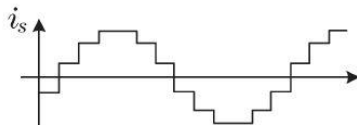
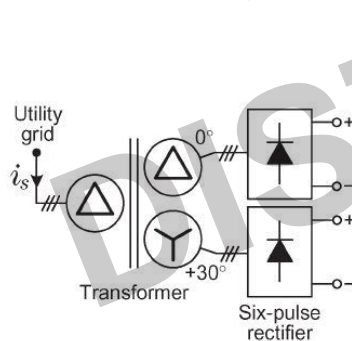

Variable Frequency Drives



Input Harmonic Solutions

- Input current and voltage THD values according to rectifier type, the short-current ratio, and a 3% DC link choke are shown.

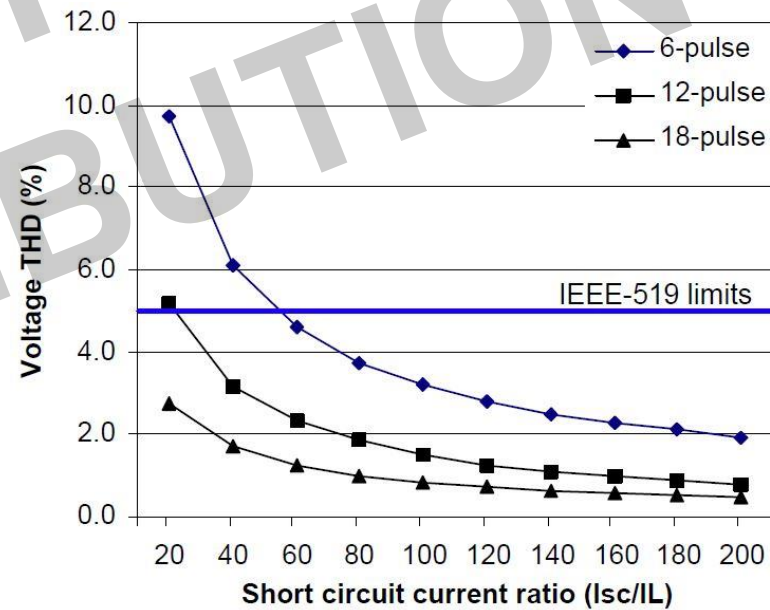
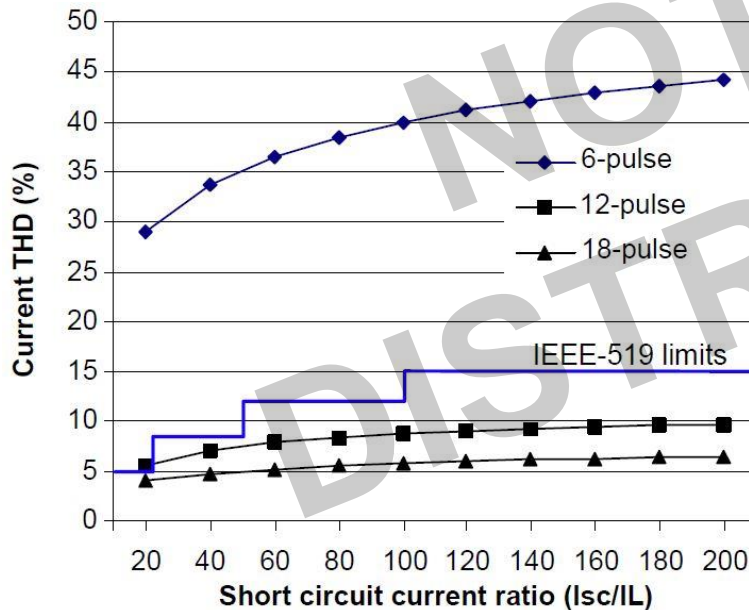

Variable Frequency Drives

Input Harmonic Solutions

- Active Front End
 - An inverter that is connected backwards and produces sinusoidal input currents using high frequency switching techniques.
 - Little current distortion, regeneration, fast response, unity power factor
 - Very expensive, very complex control
 - Generate significant high frequency current and voltage, require large line reactors and capacitors (input filter)
 - Low efficiency (extra 2% loss), Possible interaction with other equipment connected to the same bus

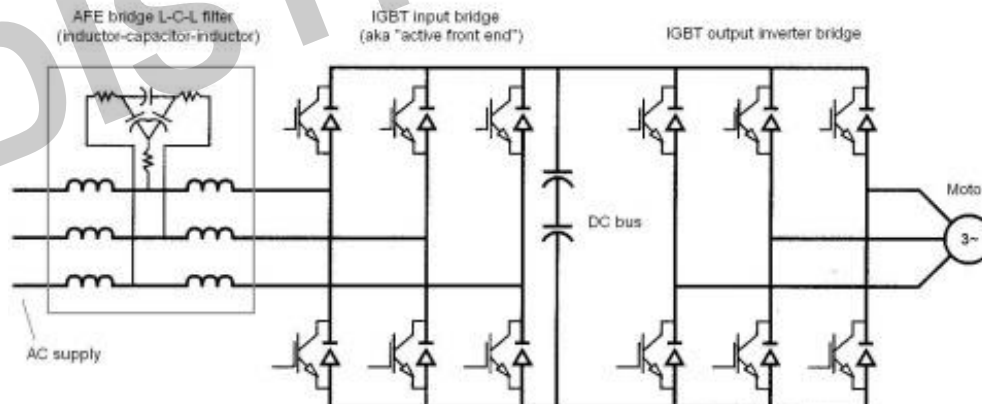

What is Power Factor?

Power Factor – Fundamentals

- Real or Active Power (P) is the actual work power: kW or HP
- Reactive Power (Q) is the power stored and discharged by the inductive and capacitive components of the power system: kVAR
- Apparent Power (S) is vector sum of the real power and reactive power: kVA
- Power system conductors and components have to be designed based on apparent power while the end user pays for the working power (kWh).

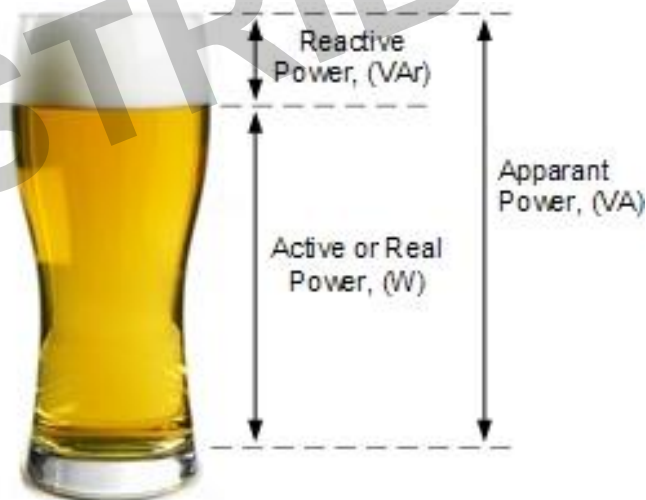

What is Power Factor?



Power Factor – Fundamentals

- Power Factor (PF) refers to the fraction of total power (apparent power) which is utilized to do the useful work (active power).
- Displacement Power Factor (DPF) references reactive power in power system and defined by the cosine of the angle between fundamental voltage and current.
- Distortion Factor (DF) references the non-working capacity due to harmonics in power system and defined by the THD values of current and voltage.

$$DPF = \frac{kW}{kVA_{fund}} \quad DF = \frac{1}{\sqrt{1 + THDv^2} + \sqrt{1 + THDi^2}}$$

$$PF = \frac{kW}{kVA} = DPF * DF$$

What is Power Factor?

Power Factor – Fundamentals

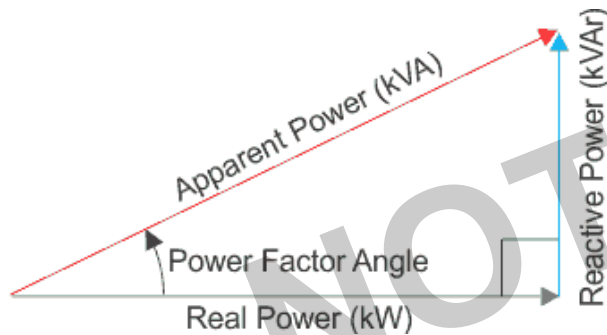

w/o non-linear equipment

$$kVA = \sqrt{kW^2 + kVAr^2}$$

$$PF = \frac{kW}{kVA} = \cos \phi$$

$$PF = DPF \quad (DF = 1)$$

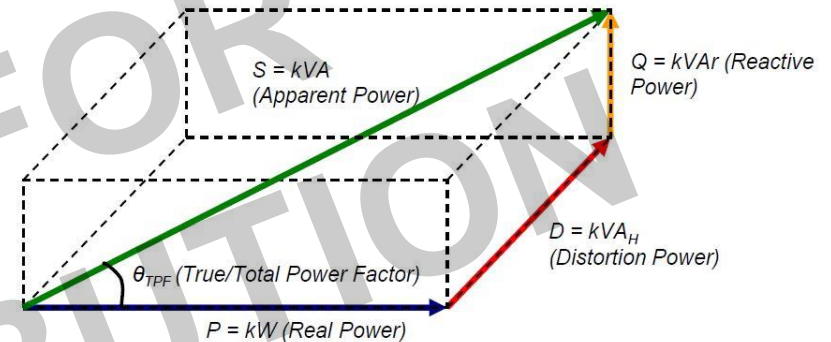

w/ non-linear equipment

$$kVA = \sqrt{kW^2 + kVAr^2 + kVAH^2}$$

$$PF = \frac{kW}{kVA} = \cos \phi_{TPF}$$

$$PF = DPF * DF \quad (DF < 1)$$

What is Power Factor?



Power Factor – Fundamentals

- Power system has to be designed for total power.
- DPF and DF are indications of wasted power system capacity.
- Poor (low) power factor increases the current flowing the power system:
 - Increased conductors and equipment sizing
 - Overheating existing power system conductors or equipment
 - Increased conductive power loss (I^2R)
 - Large voltage drops resulting in poor voltage regulation
 - Impacts of excessive harmonics

NOT FOR DISTRIBUTION

Variable Frequency Drives



Power Factor – Motors DOL vs. VFDs on line

- VFDs improve the DPF due to the operation of rectifiers.
- VFDs worsen the DF due to the added harmonics.
- VFDs can improve PF.
- Typical requirement: $PF > 0.95$

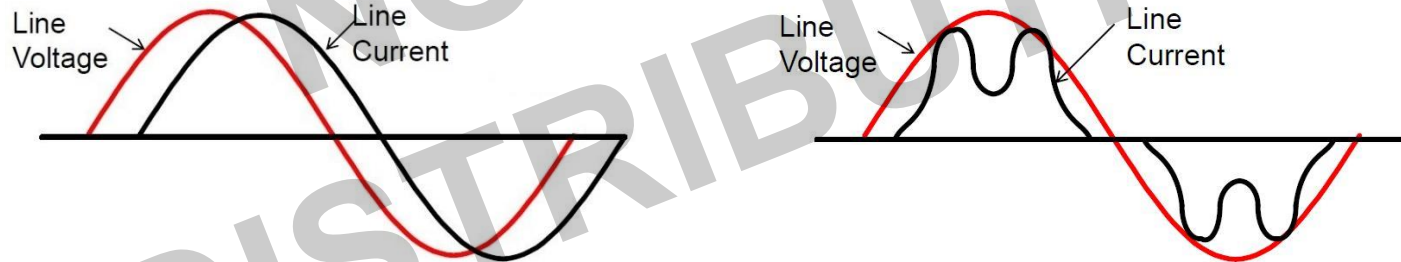

Motor direct on line

Typical DPF = 0.8 ~ 0.92

Typical DF = ~0.99

Typical PF = 0.8 ~ 0.92

VFD on line

Typical DPF = 0.95 ~ 0.999

Typical DF = 0.90 ~ 0.999

Typical PF = 0.85 ~ 0.999

Variable Frequency Drives



Reliability - Fundamentals

- Product reliability is defined as the probability that a device or equipment will perform its required function, subjected to stated conditions, for a specific period of time.
- There are two ways to look into reliability of any equipment:
 - At component level
 - At system level
- FIT rates, MTBF and MTTF are used to describe reliability of any system.

NOT FOR DISTRIBUTION

Variable Frequency Drives



Reliability - Fundamentals

- FIT (Failure in Time)
 - Defined as number of failures in billion hours.
 - Standard industry method to describe reliability of semiconductors and other electrical devices.
 - The value is produced by manufacturers.
- MTTF (Mean Time to Failure)
 - Defined as a predicted average time to failure of a device or system.
 - Standard industry method to describe reliability of non-repairable systems.
- MTBF (Mean Time Between Failure)
 - Defined as a predicted elapsed time between inherent failures of a system.
 - Standard industry method to describe reliability of repairable systems.
 - There are several methods to calculate this value.

Variable Frequency Drives

Reliability - VFDs

- FIT (no dimension) is used as measure of how frequently components fail.
- Power switches and capacitors are least reliable components.
- MTBF (in hours or years) is used as a measure, on average, of how frequently a user might expect to have his operation interrupted due to an internal problem with the VFD.
- For a VFD, MTBF can be calculated as the inverse of all the system components' FIT rates added up.

$$MTBF = \frac{1}{\Sigma \text{ components FIT}}$$

- MTBF matters, but a chain is only as strong as its weakest link.

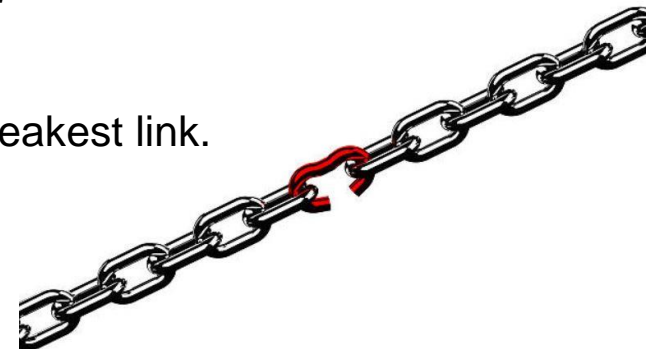

Variable Frequency Drives



Reliability - VFDs

- Manufacturers assumptions and considerations derived from operational records make MTBF values not comparable.
- Reliability of a VFD can be improved during design by:
 - Using components with lower FIT
 - Using components with high quality
 - Imposing components to power conditions below nominal ratings
 - Optimizing the number of components
- Reliability of a VFD can be improved during operation by:
 - Operating VFD within its ratings
 - Following regular preventive maintenance
 - Controlling environmental conditions

Variable Frequency Drives



Serviceability - Fundamentals

- Serviceability is an expression of the ease with which a component, device or equipment can be maintained and repaired.
- MTTR (Mean Time to Repair)
 - Defined as the average time required to repair a failed component, device or equipment.
 - Standard industry method to describe serviceability of repairable systems.

NOT FOR DISTRIBUTION

Variable Frequency Drives



Serviceability - VFDs

- Serviceability of a VFD can be improved during design by:
 - Creating a modular design
 - Designing for front access only
 - Designing for lower MTTR (typically 30 minutes)
- Serviceability of a VFD can be improved during operation by:
 - Following regular preventive maintenance
 - Controlling environmental conditions
 - Having spare parts on hand
 - Providing required space for maintenance
 - Creating and following standard maintenance processes

Variable Frequency Drives



How to specify one?

- Specify the load
 - Load type: fan, pump, compressor
 - Load curve: variable torque (light duty), constant torque (heavy duty)
 - Process: start-up only, speed control, speed range, load size
- Specify the motor
 - Ratings: voltage, current, required current curve
- Specify output waveform quality requirements
 - Hint: specify requirements instead of specifying how to meet them.
- Specify the input line
 - Ratings: voltage, quality (dips, fluctuations, over-voltages)
- Specify input power quality requirements
 - Hint: specify requirements instead of specifying how to meet them.

Variable Frequency Drives



How to specify one?

- Specify interface requirements
 - HMI: size, location, remote or local
 - I/Os: DIs, DOs, AIs, AOs
 - Communication: Ethernet protocols such as Modbus TCP/IP and Profibus DP
- Specify installation requirements
 - Type of installation: all indoor (E-house), all outdoor, mixed
 - Type of enclosures: NEMA 1, NEMA 3R, NEMA 4
 - Type of cooling: air-cooled, liquid-cooled
 - Site limitations: size (area), height
- Specify environmental conditions
 - Temperatures: min, max, average
 - Humidity: min, max, average, condensation
 - Altitude: impacts cooling system, impacts design



Variable Frequency Drives - MV

Medium Voltage Drives

Topologies – Overview

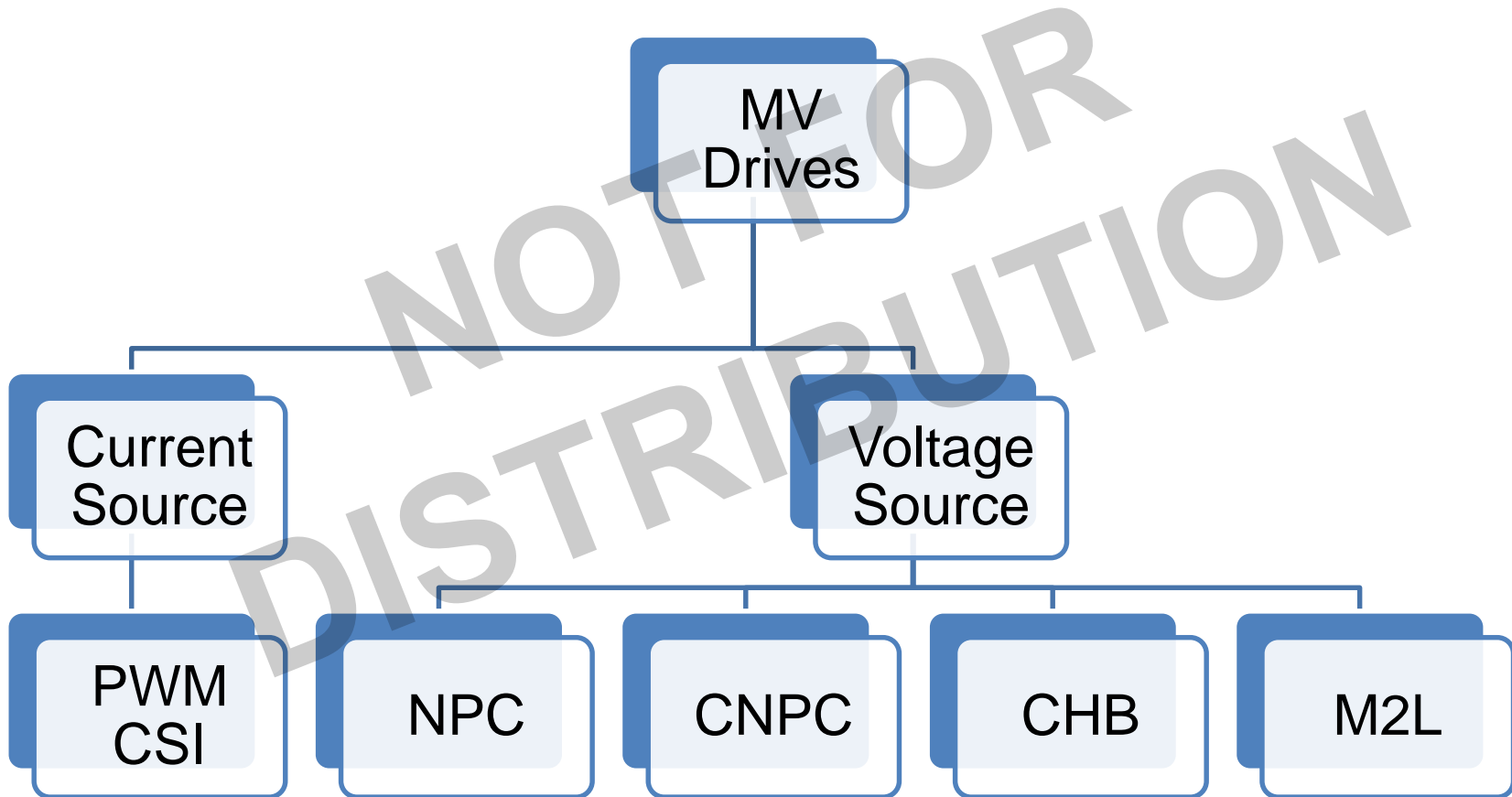

Medium Voltage Drives

Topologies – Fundamentals

- MV drives are recognized by their inverter topology.
- Inverter topology defines drive's output performance and motor compatibility.
- Rectifier topology can be independent from inverter (non-cascaded topologies) or dependent on inverter topology (cascaded topologies).
- Rectifier topology defines drive's input performance and line compatibility.

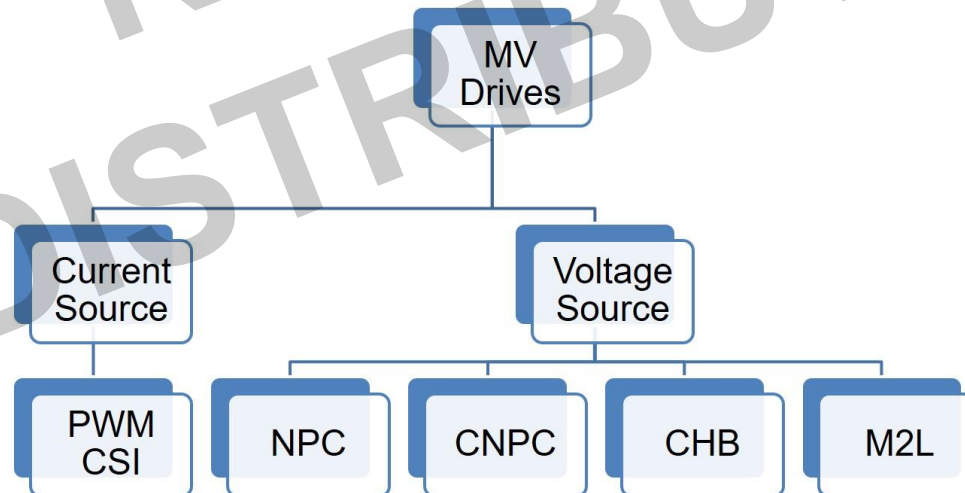

Medium Voltage Drives

Topologies – Fundamentals

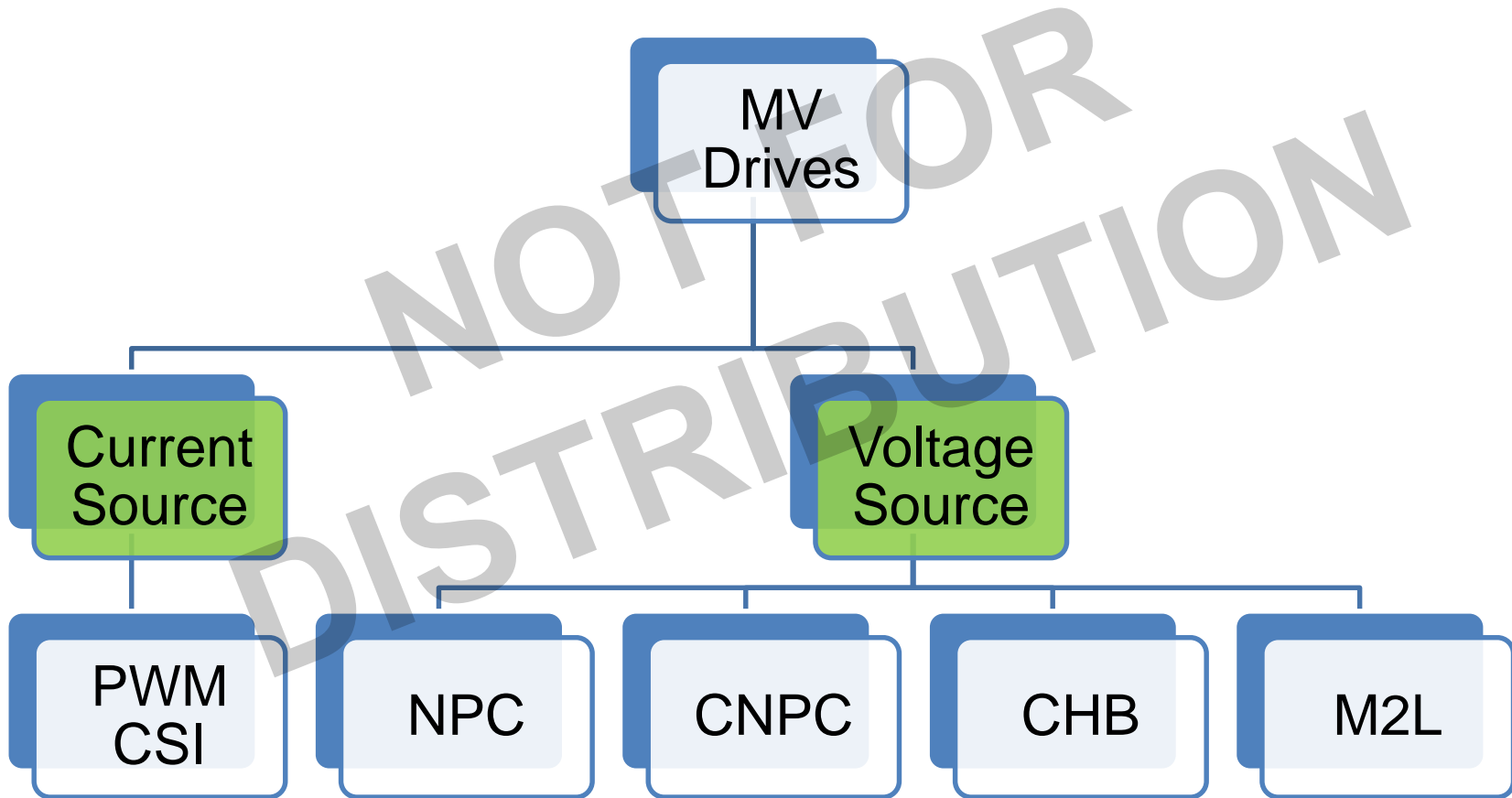

Medium Voltage Drives

Topologies – Fundamentals

- Main categories are Current Source and Voltage Source topologies.
- The topological difference is the dominant components used on the DC link.
- Current Source topologies have inductive DC link.
- Voltage Source topologies have capacitive DC link.

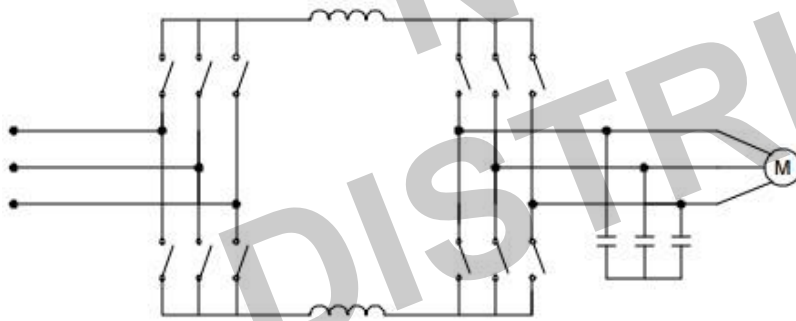

Current Source Inverter

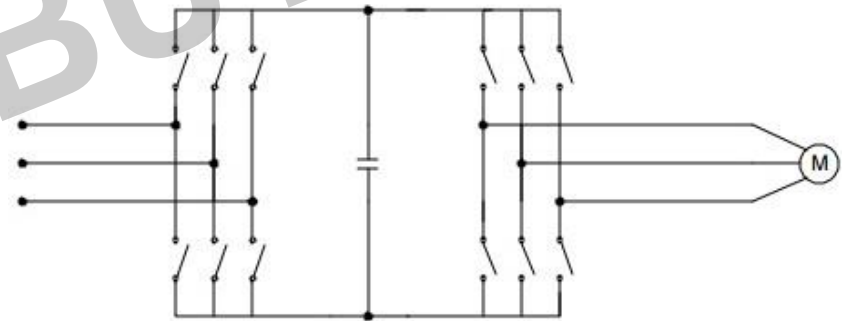

Voltage Source Inverter

Medium Voltage Drives

Topologies – Current Source

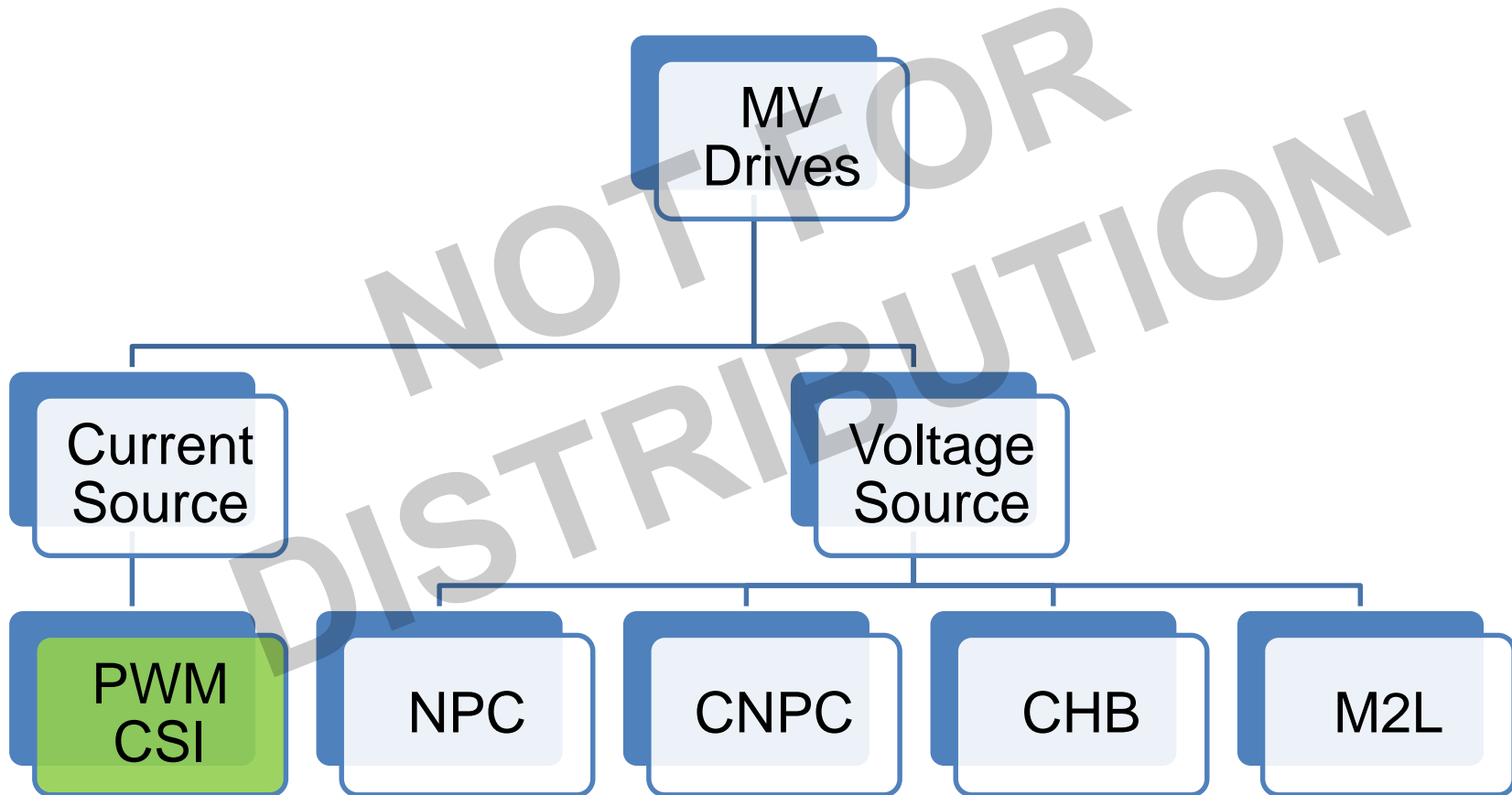

Medium Voltage Drives

Topologies – Current Source

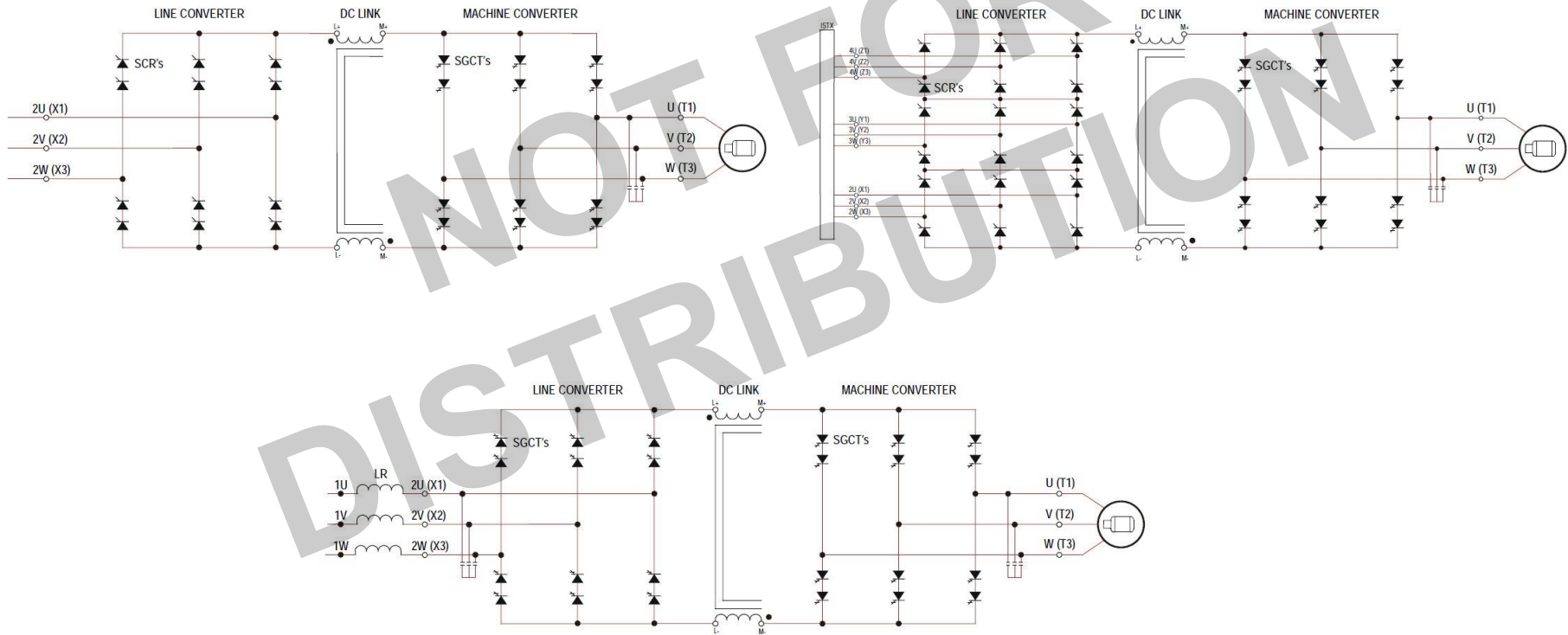

Medium Voltage Drives

Topologies – Current Source

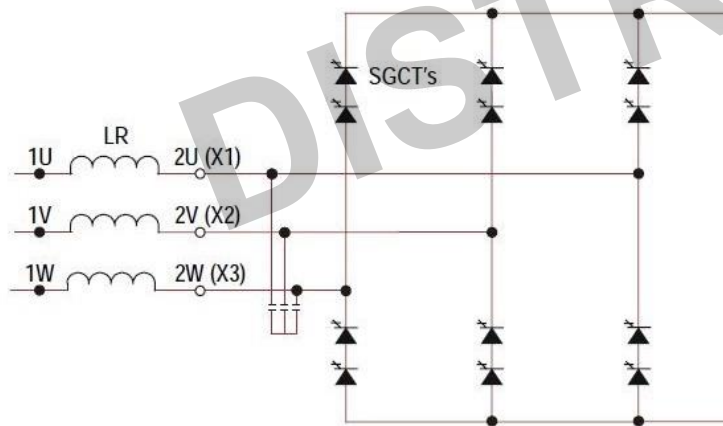
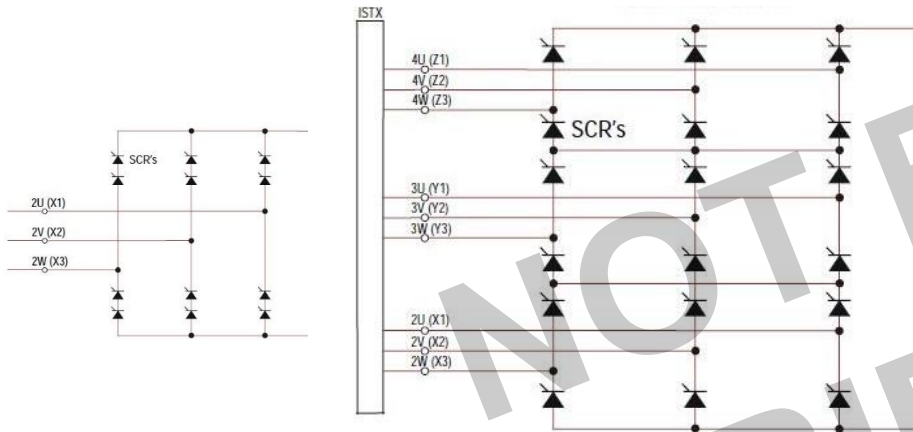

- Input Transformer
 - Required w/ multi-pulse
 - Independent component
 - Standard multi-pulse
 - Low number of secondary connections

Rectifier

- Independent component
- Standard multi-pulse
- Low number of switches

w/ AFE only

- SGCTs required
- Complex input filter required

Medium Voltage Drives

Topologies – Current Source

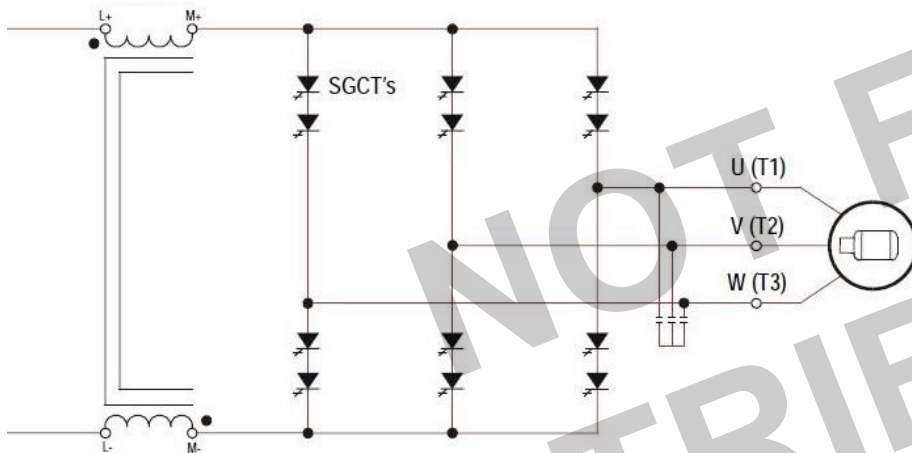

- DC link
 - Concentrated energy storage
 - Bulky and heavy inductors
- Inverter
 - Non-modular
 - Complex power modules
 - Complex output filter

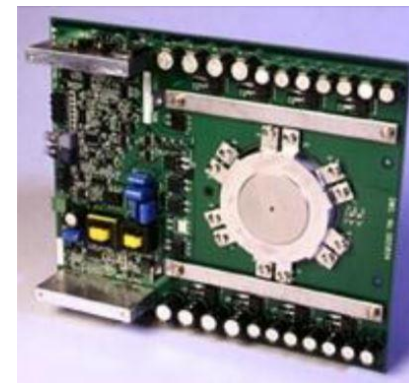
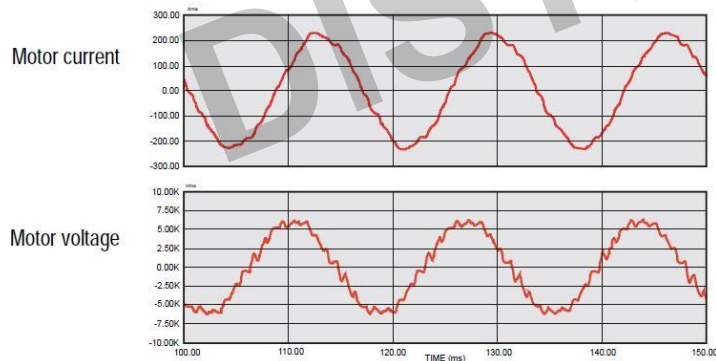

Medium Voltage Drives

Topologies – CS vs. VS

- The output of the inverter is a current (typically DC link current)
- The motor and its load determine the voltage
- Immune to short circuit thanks to DC inductors limiting fault current
- Very low dynamic performance due to large DC inductors
- The output of the inverter is a voltage (typically DC link voltage)
- The motor and load determine the current that flows
- Need short circuit detection and protection system
- High dynamic performance limited only by control loop delays

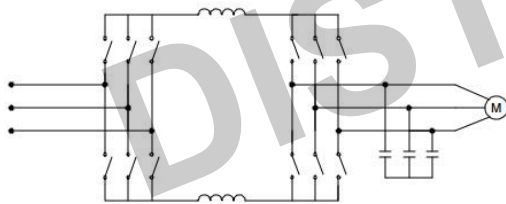

Current Source Inverter

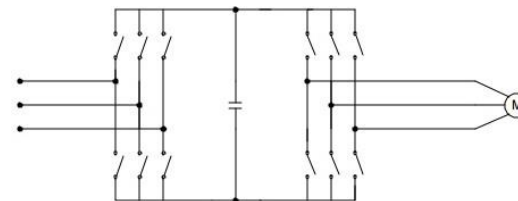

Voltage Source Inverter

Medium Voltage Drives

Topologies – CS vs. VS

- Input harmonic filter required with 6-pulse rectifier and AFE configuration
- PF = PU Speed * Load PF
- Output filter always required resulting in low dV/dt and unlimited distance to motor
- 92% - 96% efficiency at full speed, as low as 65% at 50% speed
- Input harmonic filter required with 6- or 12- pulse rectifiers
- PF is 0.95 or higher
- Output filter required with 5- or 9-level inverters and with long distance to motor applications
- 96% - 98% efficiency at full load, full speed, Typically stays above 95%

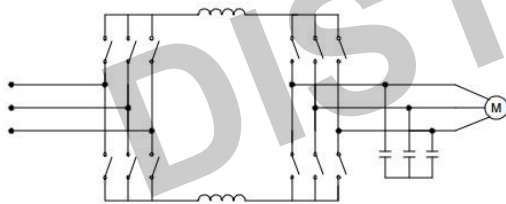

Current Source Inverter

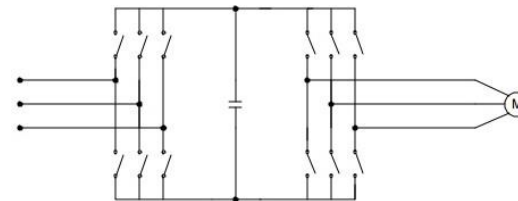

Voltage Source Inverter

Medium Voltage Drives



Topologies – Neutral Point Clamp

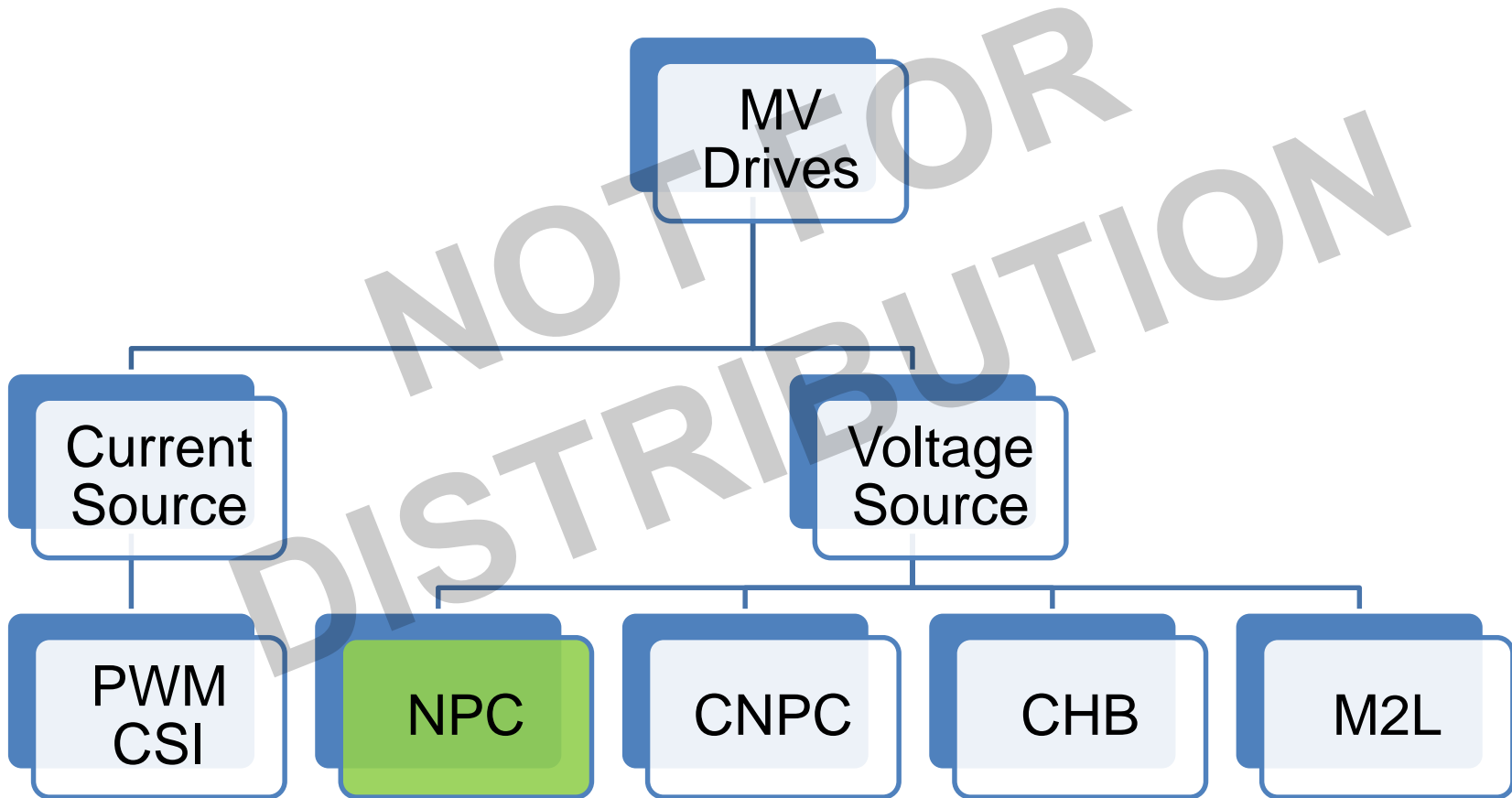

Medium Voltage Drives

Topologies – Neutral Point Clamp

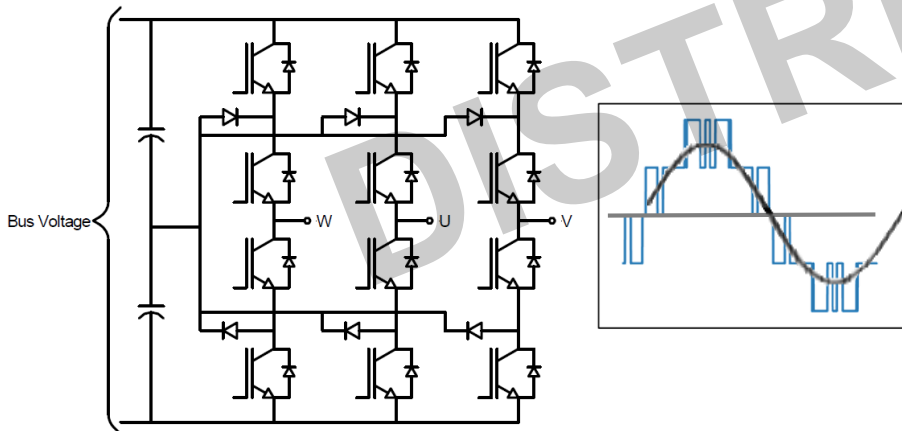
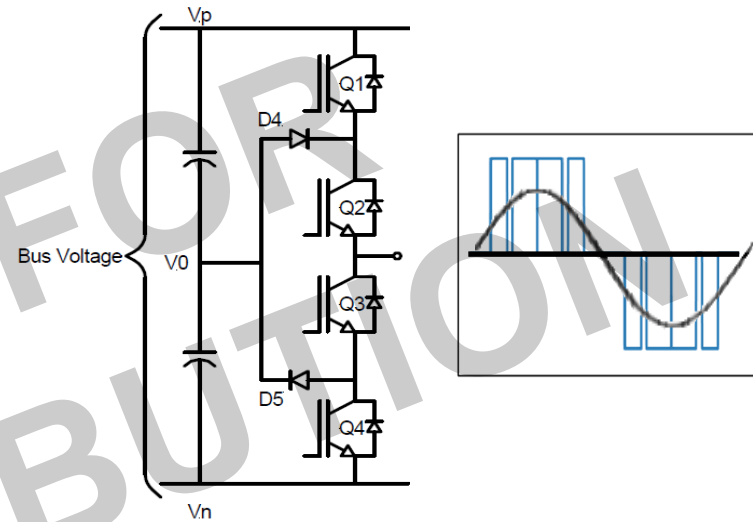
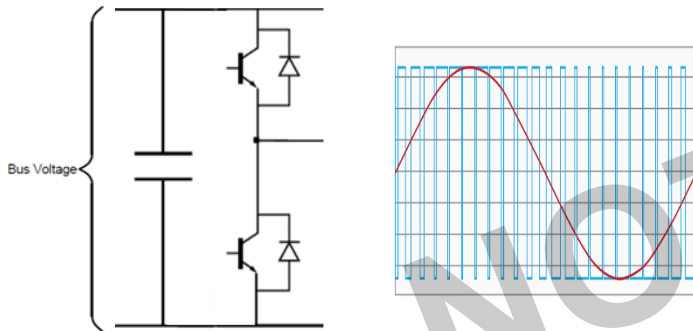

- 2-level is dominant topology found in LV applications
- Extended to 3-level by adding more IGBTs and diode
 - Increasing voltage level
 - Increasing levels of voltage waveform

Topologies – Neutral Point Clamp

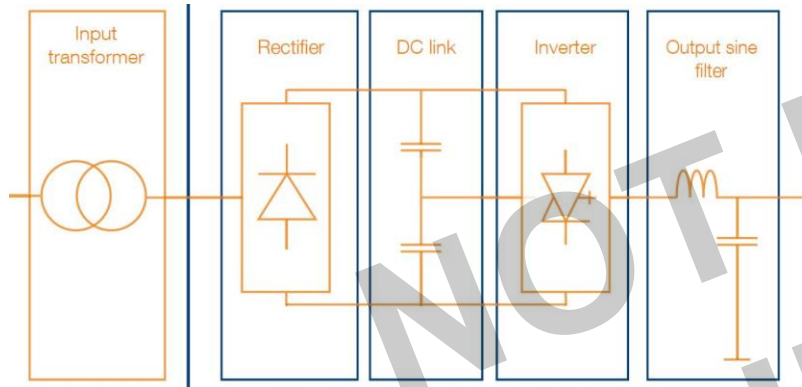

- Input transformer
 - Independent component
 - Standard multi-pulse
 - Low number of secondary connections
- Rectifier
 - Independent component
 - Standard multi-pulse
 - Low number of diodes

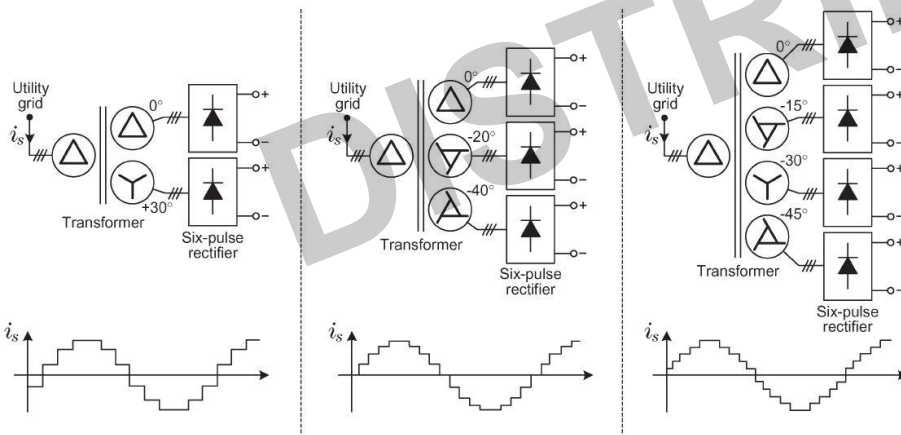

Medium Voltage Drives

Topologies – Neutral Point Clamp

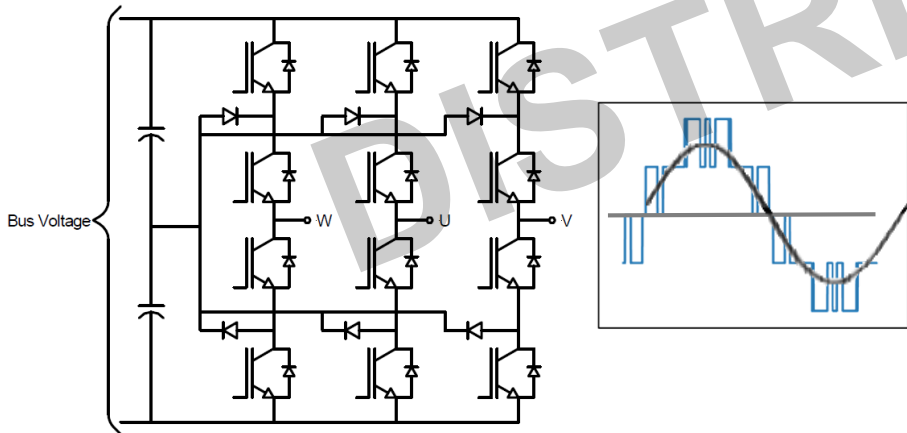
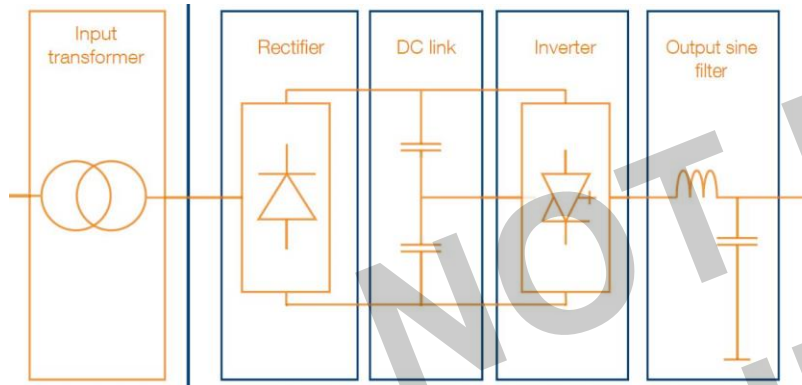

- DC link
 - Concentrated energy storage
 - Bulky capacitor bank
 - Oil-filled film caps
- Inverter
 - Non-modular
 - High voltage power modules
 - 5-level voltage waveform
 - High output harmonics
 - High dV/dt
 - Output filter required

Medium Voltage Drives

Topologies – Cascaded Neutral Point Clamp

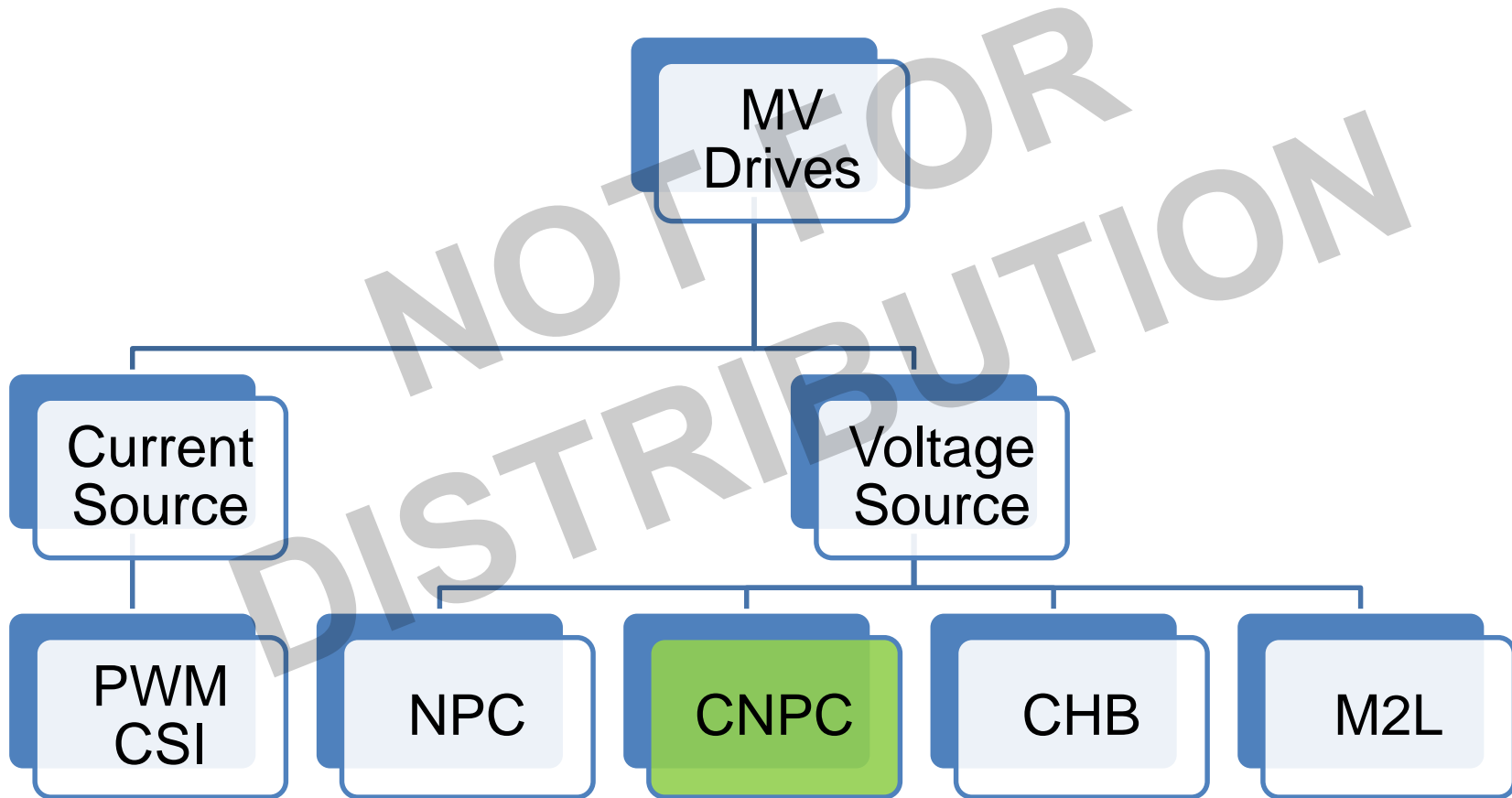

Medium Voltage Drives

Topologies – Cascaded Neutral Point Clamp

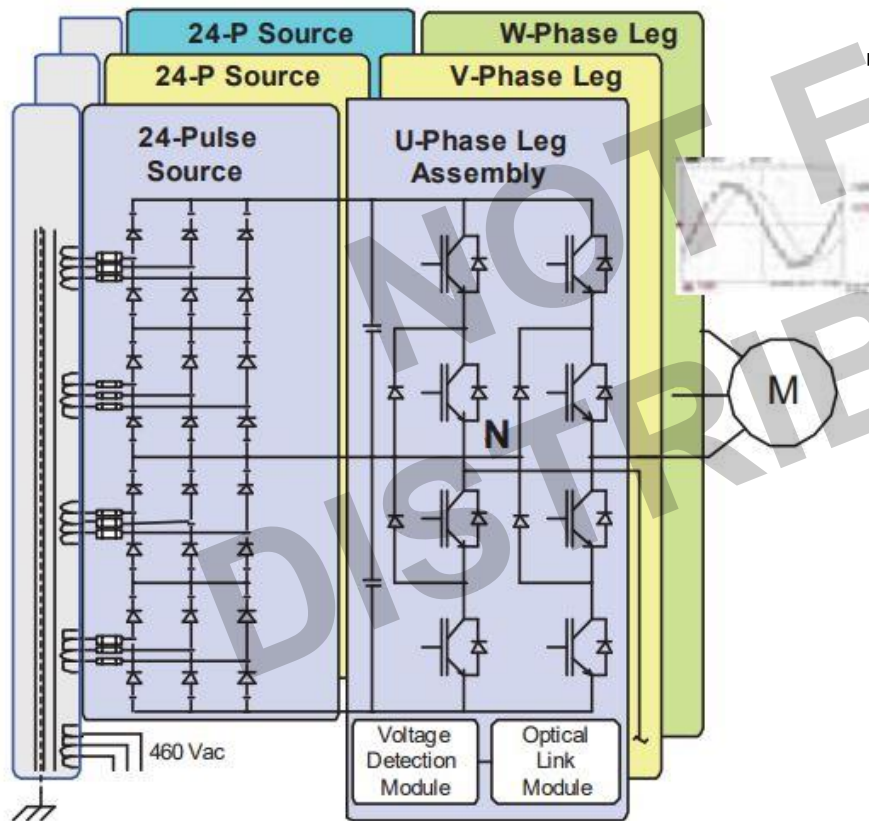

- NPC modules connected in series
 - Increasing reliability
 - reducing the required voltage rating of power modules (6500 V to 3300 V IGBTs)
 - Improving output waveform quality
 - increasing number of levels on voltage waveforms (5 levels to 9 levels)

Topologies – Cascaded Neutral Point Clamp

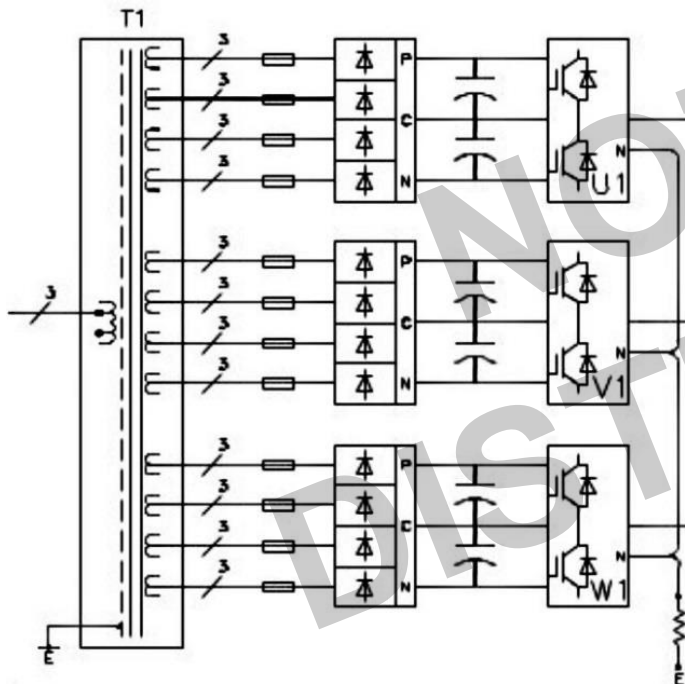

- Input transformer
 - Integrated component
 - Must be 24-pulse, no options
 - High number of secondary cables (36 terminals)
- Rectifier
 - Integrated into inverter section
 - Must be 24-pulse, no options
 - Very high number of components

Topologies – Cascaded Neutral Point Clamp

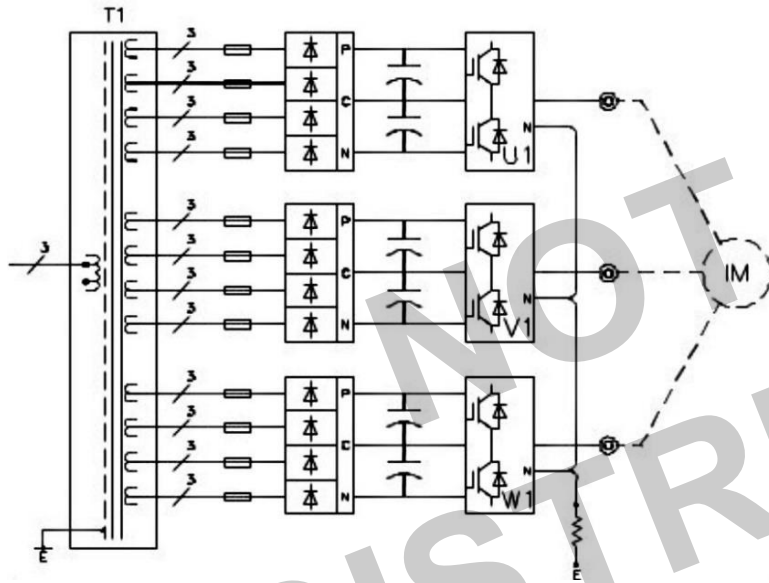

- DC link
 - Semi-distributed energy storage
 - Film caps or electrolytic caps
- Inverter
 - Semi-modular
 - Huge power cells
 - High voltage switching modules
 - 9-level voltage waveform
 - Average output harmonics
 - Average dV/dt

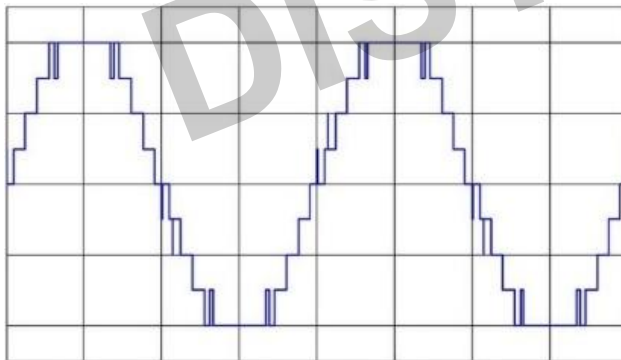

Medium Voltage Drives



Topologies – Cascaded H-Bridge

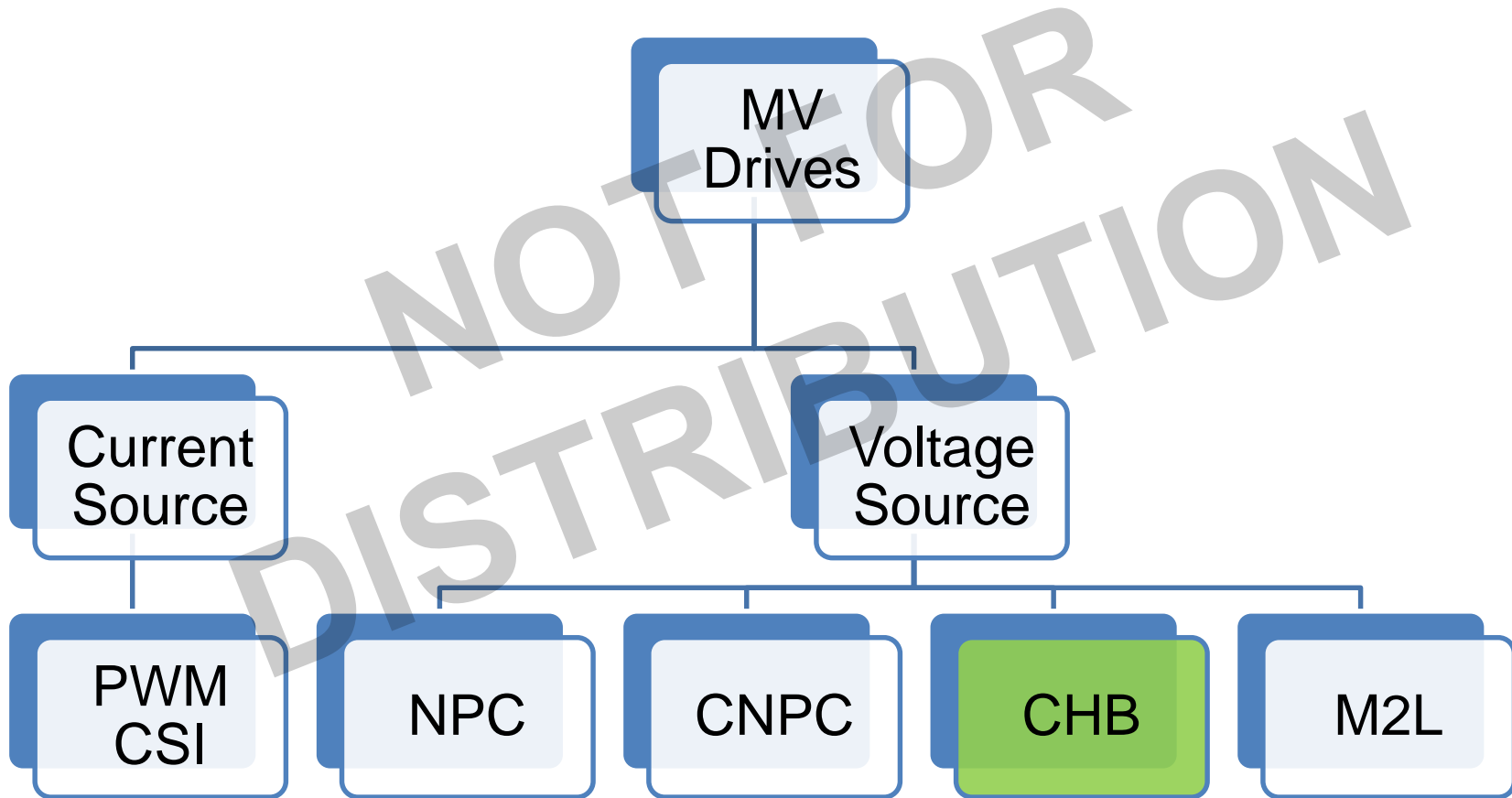

Medium Voltage Drives

Topologies – Cascaded H-Bridge

- Developed to overcome 3 major problems with NPC topologies
 - High voltage switching modules
 - Poor output waveforms
 - Concentrated bulky DC link
- Each H-bridge power cell is a LV VFD!

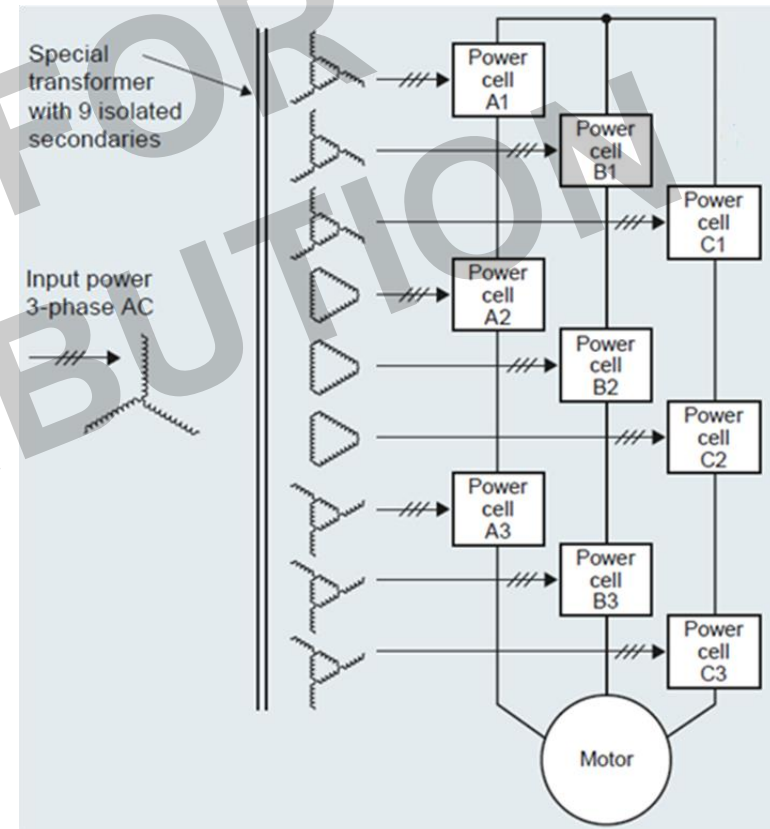
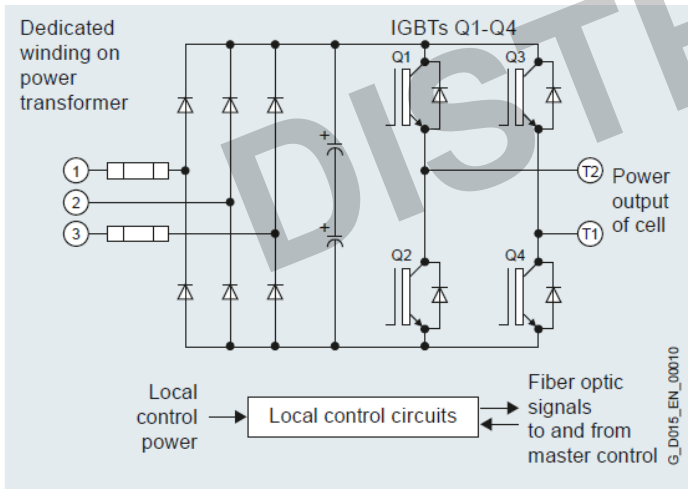

Topologies – Cascaded H-Bridge

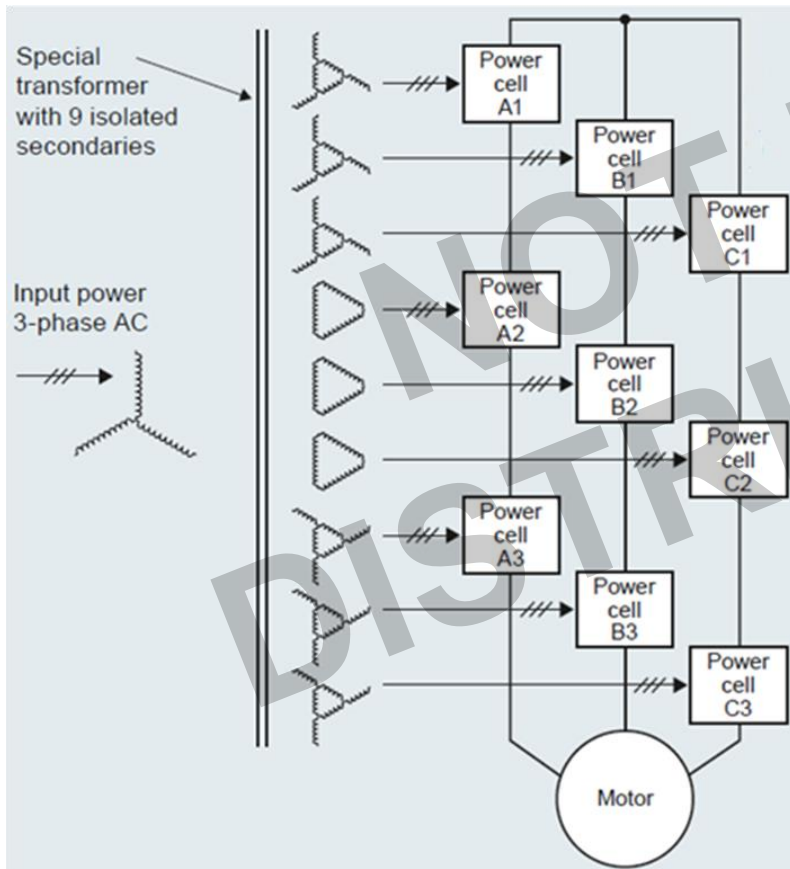

- Input transformer
 - Integrated component
 - Must be 18-pulse, no options
 - High number of secondary cables (27 terminals)
- Rectifier
 - Integrated into inverter power cells
 - Must be 18-pulse, no options
 - Very high number of components

Medium Voltage Drives

Topologies – Cascaded H-Bridge

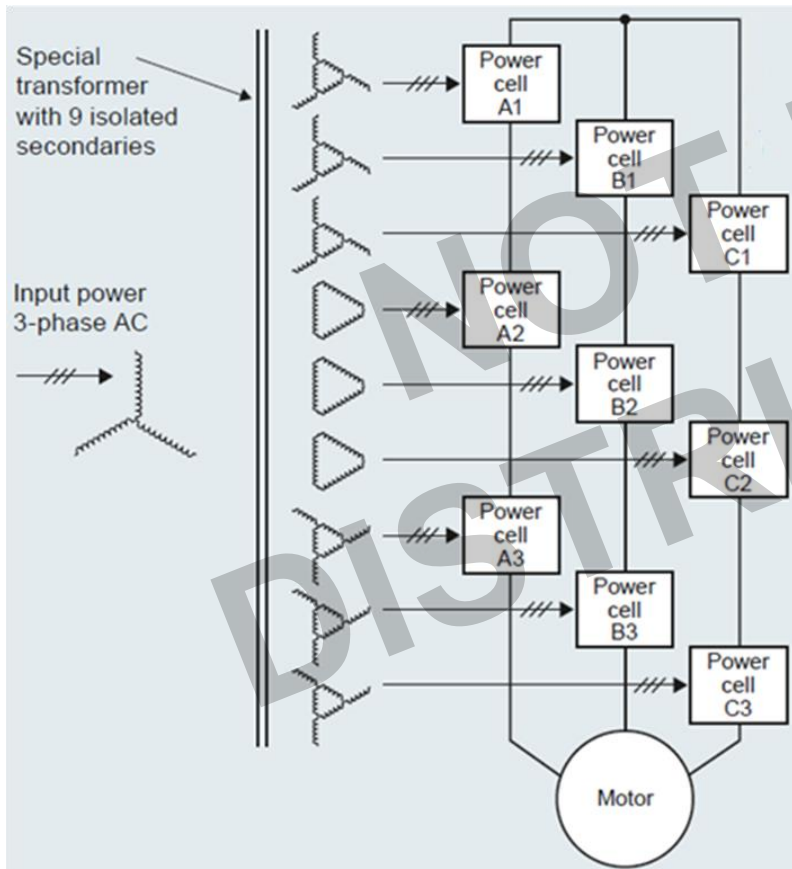

- DC link
 - Distributed energy storage
 - Electrolytic capacitors
- Inverter
 - Modular
 - Low voltage switching modules (1700 V IGBTs)
 - 13-level voltage waveform
 - Low output harmonics
 - Low dV/dt

Medium Voltage Drives

Topologies – Modular Multi-Level

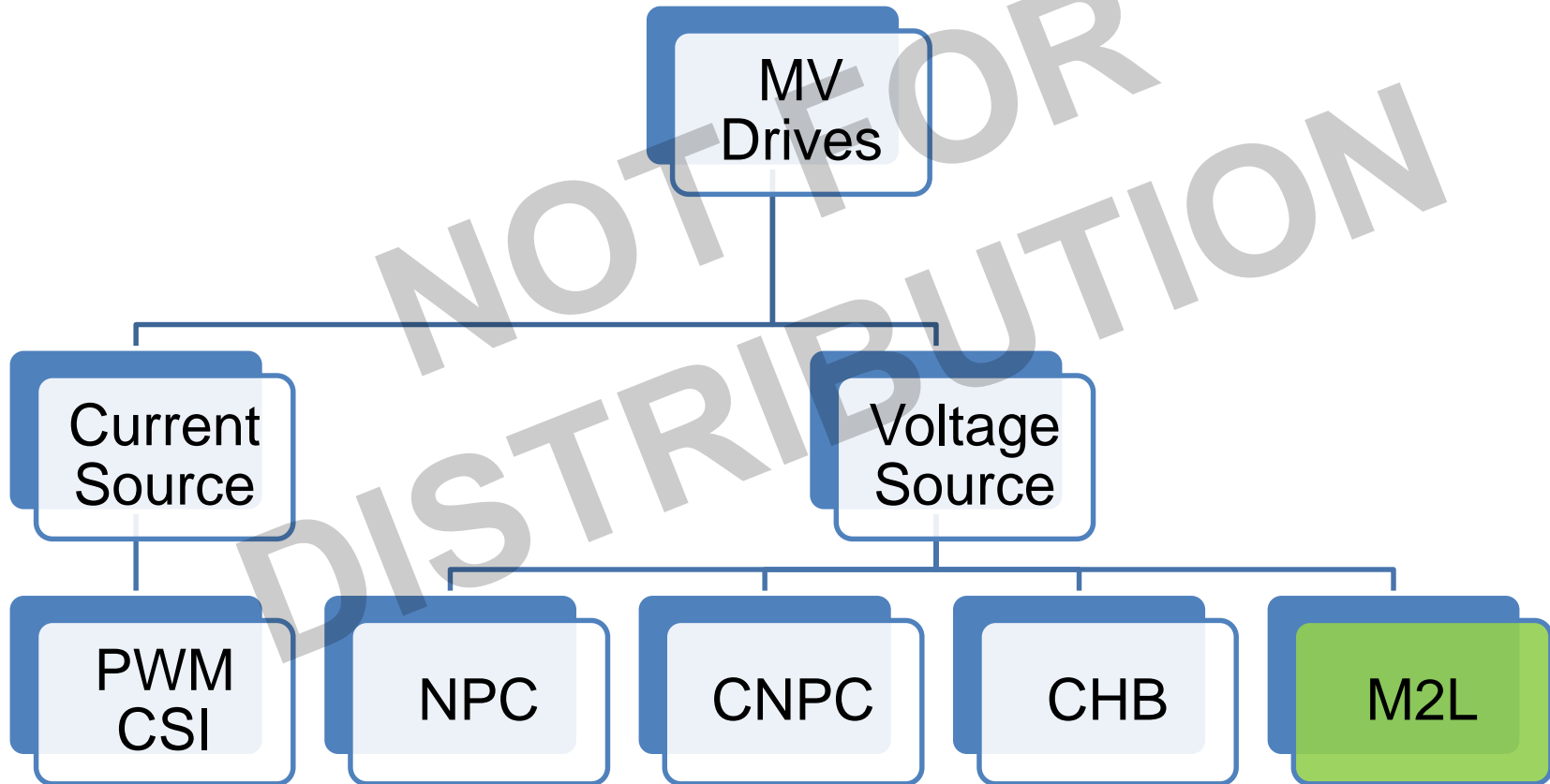

Medium Voltage Drives

Topologies – Modular Multi-Level

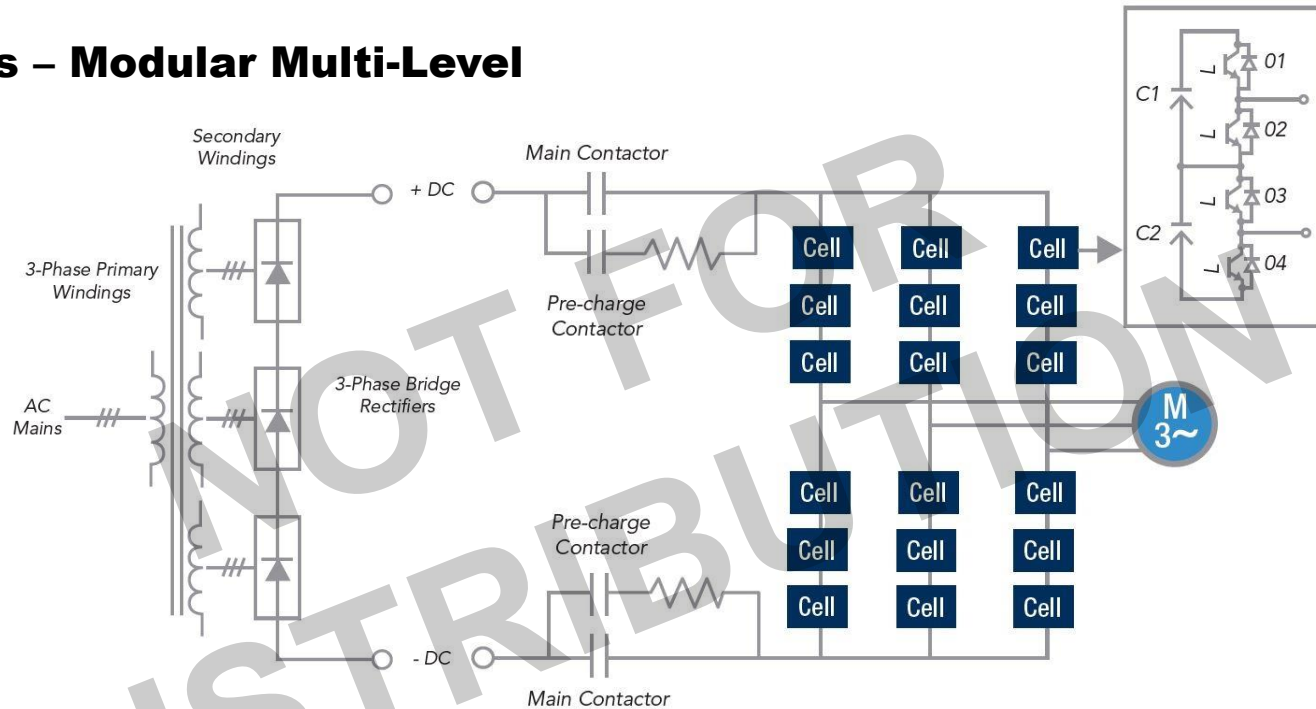

- Input transformer and rectifier are similar to NPC drives.
 - Independent components
 - Flexible in design and installation
- No bulky DC capacitor bank
- DC filter and inverter are based on CHB drives.
 - Distributed energy storage
 - LV power cell based inverter
- No electrolytic capacitors

M2L MV Drive

Main Components - Transformer

- Standard multi-pulse transformer
 - Simple and reliable design
 - 6-, 12-, 18-, 24-, 36-pulse
 - Indoor or outdoor installation
 - AF dry-type, AN dry-type or ONAN
 - Low number of secondary connections (9 instead of 27, 12 instead of 36)
 - High efficiency (>98%)
 - End user's existing transformer

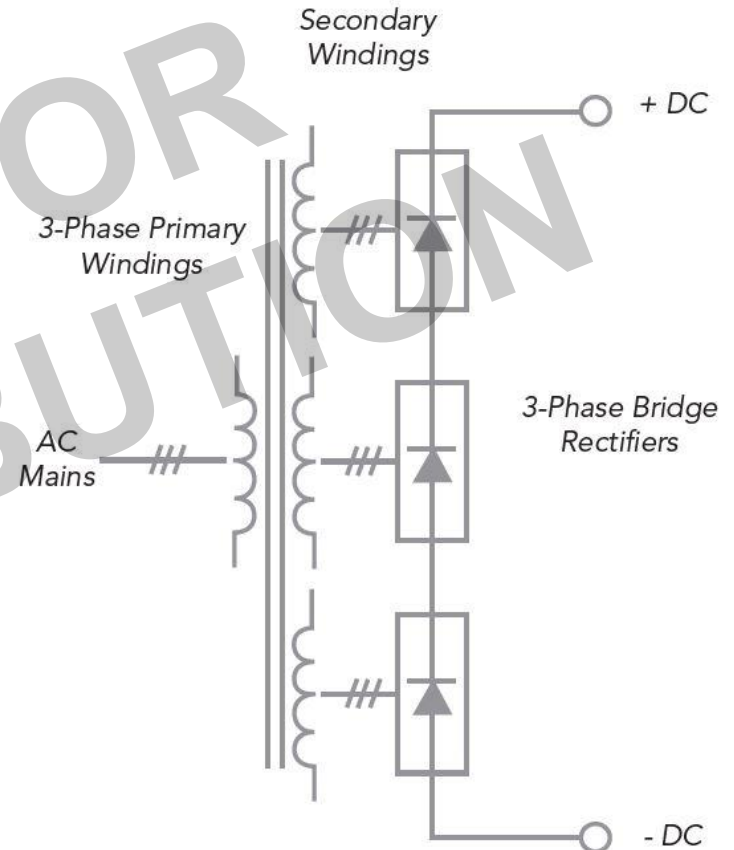

M2L MV Drive



Main Components - Rectifier

- Standard multi-pulse rectifier
 - Simple and reliable design
 - 6-, 12-, 18-, 24-, 36-pulse
 - Indoor or outdoor installation
 - NEMA 1 or NEMA 3R
 - Low number of diodes
 - High efficiency (>99.5%)
 - Fused on all input three phases
 - 2 DC output cables (to inverter)
 - No DC capacitors
 - End user's existing rectifier

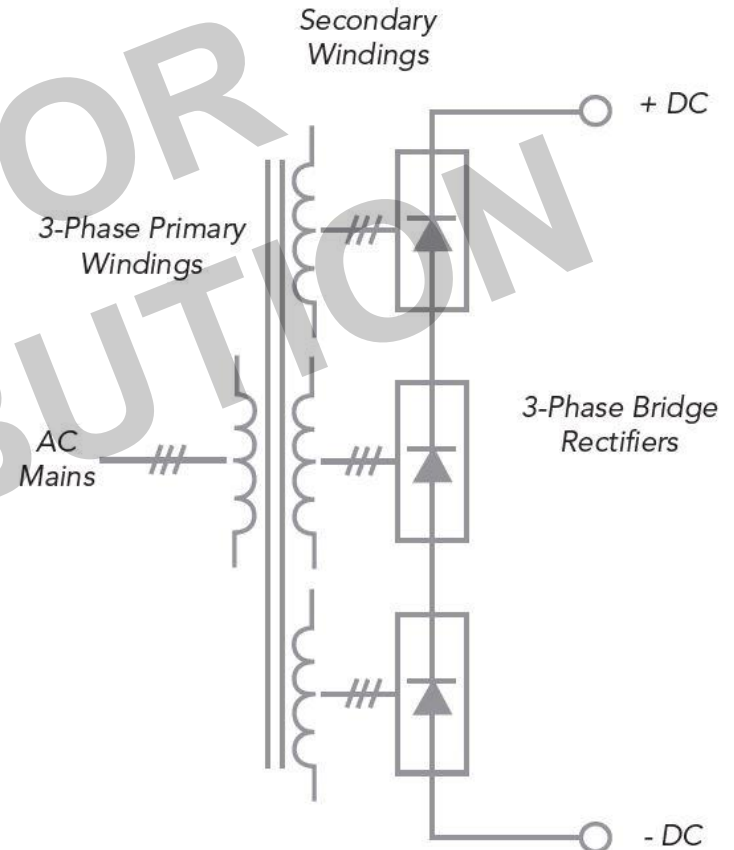

M2L MV Drive



Main Components - Inverter

- Modular multi-level inverter
 - LV power cell based
 - 18 cell (4160 V), 30 cell (6900 V), 36 cell (7200 V)
 - Indoor (NEMA 1)
 - Standard pre-charge circuit
 - Intelligent power cells w/ fiber optic communications
 - Reliable low voltage IGBTs (1700 V)
 - Fully distributed DC energy storage
 - Dry type film capacitors
 - High efficiency (>99.5%)

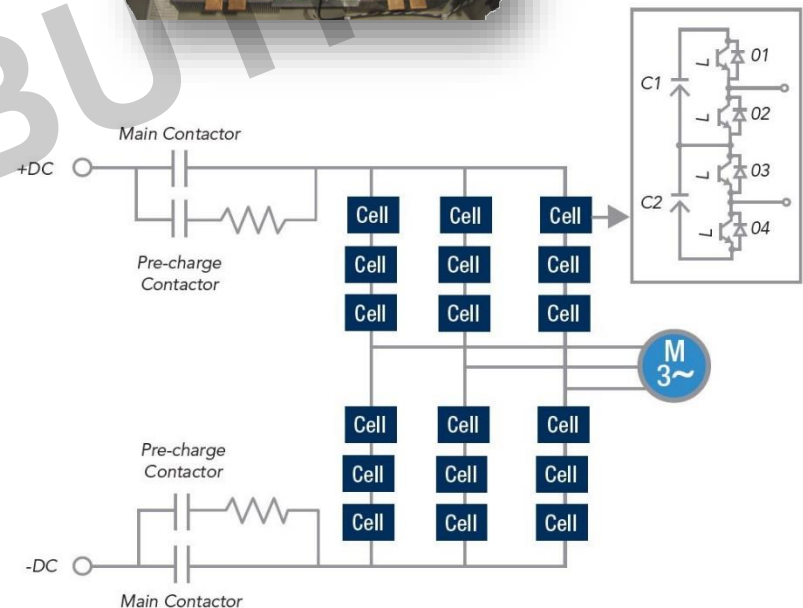

Performance – Output and Input

- Excellent output power quality
 - Motor friendly not causing extra heating or insulation stress
 - 13-level voltage waveform
 - Low dV/dt
 - No need for output filter

- Excellent input power quality
 - 18-pulse meets IEEE 519 requirements
 - Minimized input harmonics
 - Input power factor higher than 0.95
 - No need for input filter

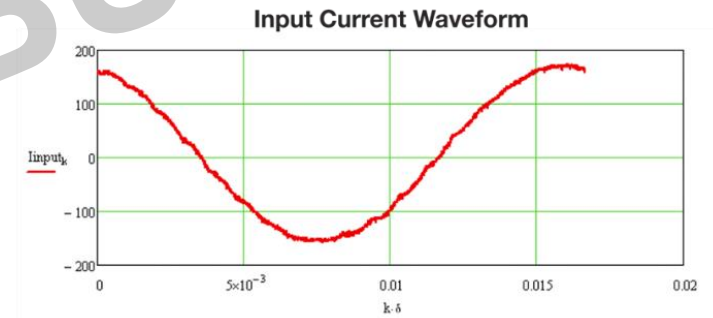
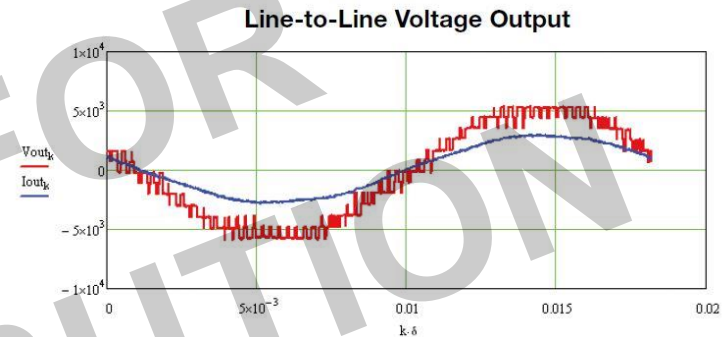

Typical Input Current Harmonics (at full load)

	5th	7th	11th	13th	17th	19th	23rd	25th	THD
Benshaw	0.78%	0.33%	0.085%	0.19%	1.45%	1.1%	0.14%	0.089%	2.28%
IEEE-519	4%	4%	2%	2%	1.5%	1.5%	0.6%	0.6%	5%

Independent Components - Benefits

- Installation flexibility
 - Reduced air-condition requirements
 - Reduced arc flash footprint
- Scalability
 - Large motor control
 - Multi-motor control

NOT FOR DISTRIBUTION

Independence
Matters^S

M2L MV Drive

FLEXIBILITY!

- Being constituted by independent components provides flexible installation options.

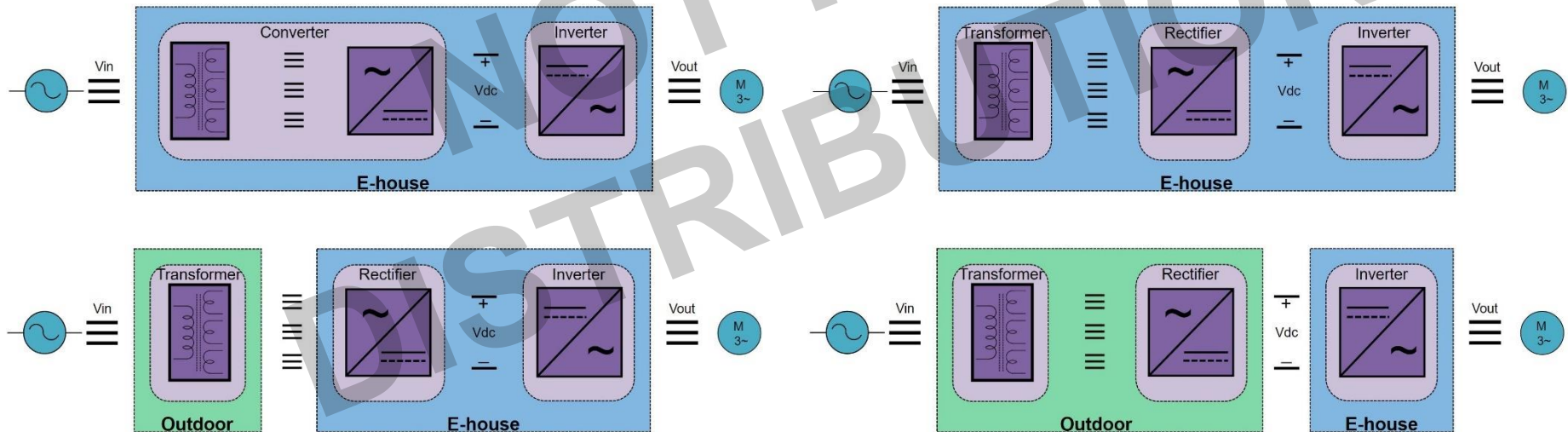

Outdoor Equipment - Benefits

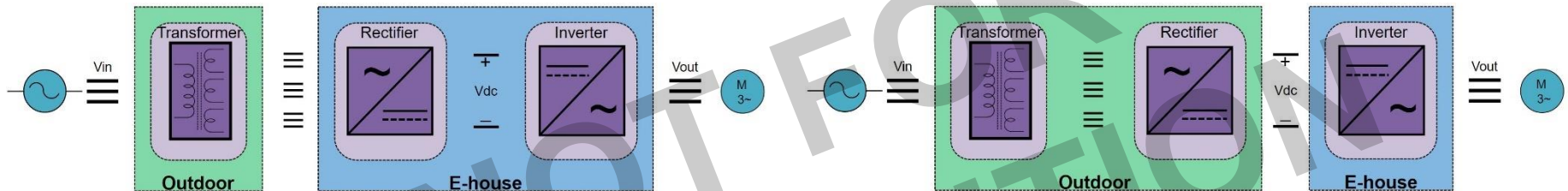

- Smaller environmentally-conditioned equipment room
 - ~50 - 60% reduction in required area
- Significantly lower required air conditioning
 - ~65 - 75% reduction in heat load
- Maximized safety and smallest arc flash footprint
 - Minimum ~50% reduction in short-circuit currents

Outdoor Equipment – Reduced Air-conditioning Requirements

- Significant savings on initial investment ,operation cost, and maintenance cost of air-conditioning systems

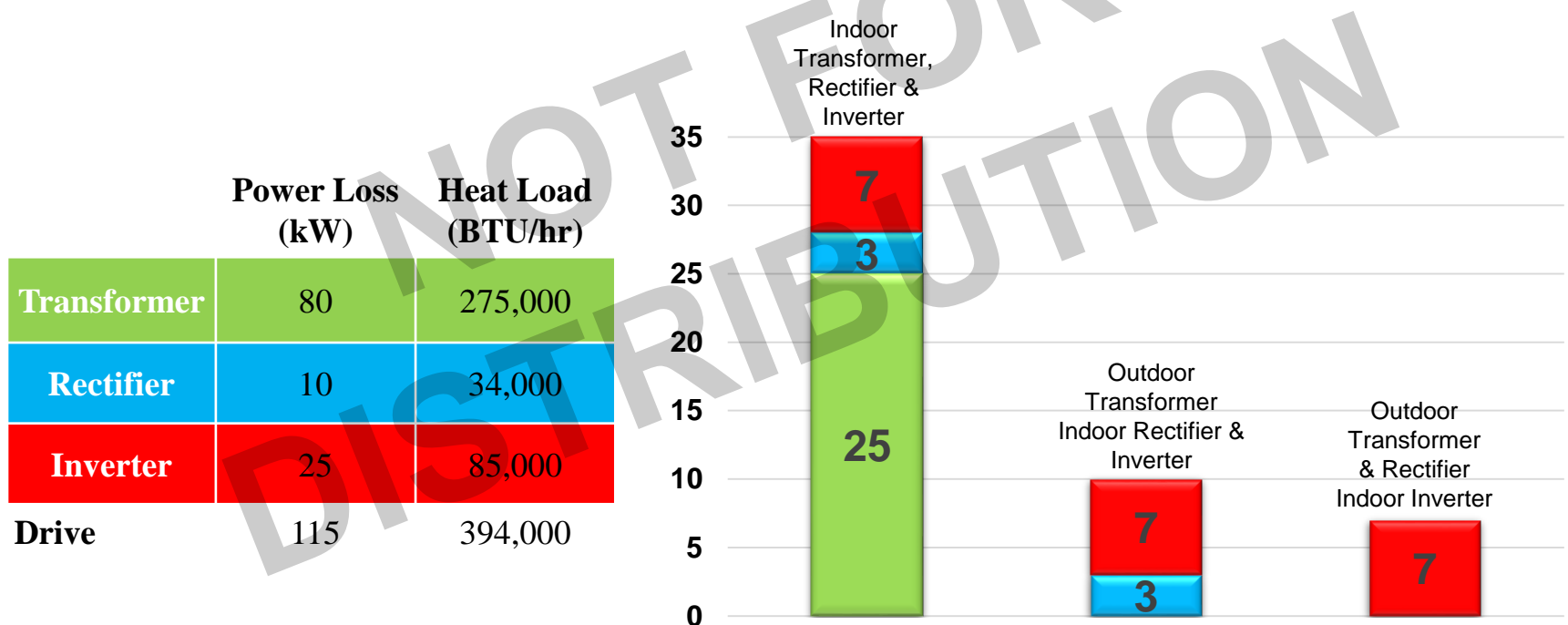

Example shown for a typical 5000 HP MV drive with 97% overall efficiency

Outdoor Equipment – Air-conditioning Cost Saving

- Significant savings on initial investment, operation cost, and maintenance cost of air-conditioning systems

	Transformer: Indoor Rectifier: Indoor Inverter: Indoor	Transformer: Outdoor Rectifier: Indoor Inverter: Indoor	Transformer: Outdoor Rectifier: Outdoor Inverter: Indoor
Required AC (tons)	35	10	7
AC Units Cost (initial cost)	\$52,500	\$15,000	\$10,500
Operating Cost (yearly)	\$36,792	\$10,512	\$7,358
Life-time Cost (20 years)	\$788,340	\$225,240	\$157,668

Estimated \$630,000 initial investment and operating cost saving for a typical 5000 HP MV drive

M2L MV Drive

Outdoor Equipment – Reduced Arc-Flash Footprint

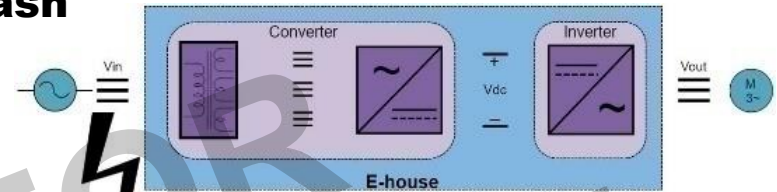
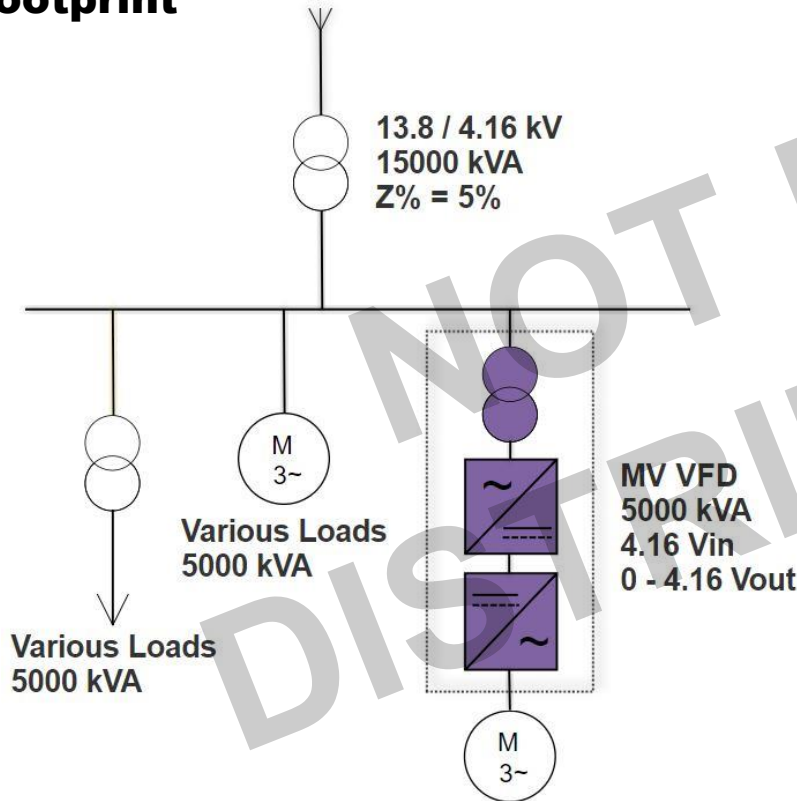

$V_{\text{Primary}} = 13.8 \text{ kV}$
 $V_{\text{Secondary}} = 4.16 \text{ kV}$
 Transformer size = 15 MVA
 System Impedance = 5%
 $I_{\text{short-circuit}} = \sim 42 \text{ kA}$

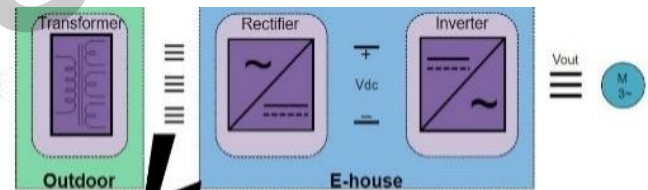

$V_{\text{Primary}} = 4.16 \text{ kV}$
 $V_{\text{Secondary}} = 1.5 \text{ kV}$
 Transformer size = 1.67 MVA
 (5000 kVA / 3 = 1667 kVA)
 Transformer Impedance = 4%
 $I_{\text{short-circuit}} = \sim 14 \text{ kA}$

Example shown for a typical 5000 HP drive supplied by a 15 MVA, 4160 V power line

M2L MV Drive

SCALABILITY!

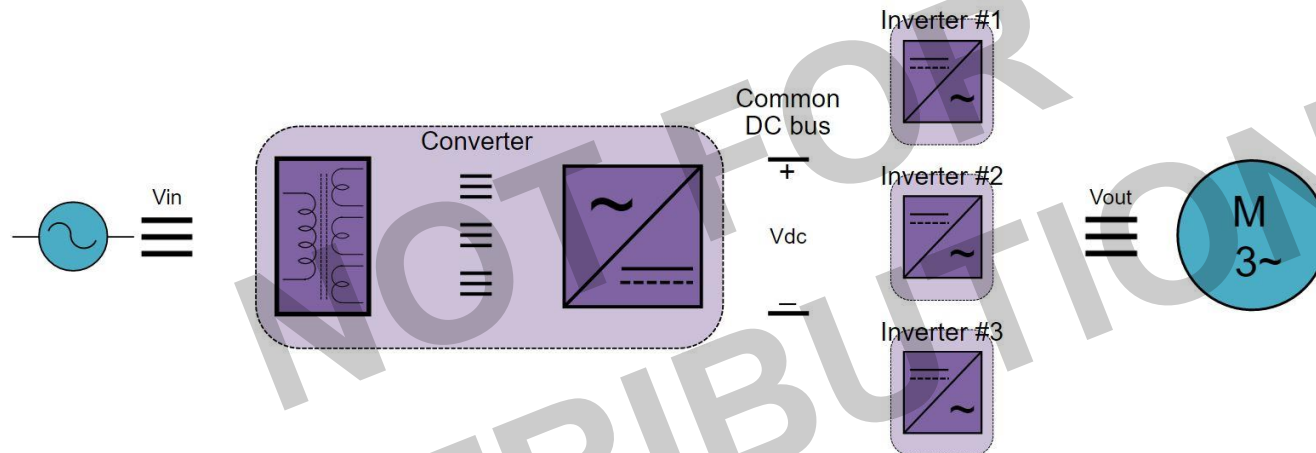

- Extending air-cooled solution for HPs beyond traditional power limits
- Significant cost savings on equipment and real estate
- Seamless control integration
- Single operator interface (HMI) and process control
- Option for redundant inverter

M2L MV Drive

SCALABILITY!

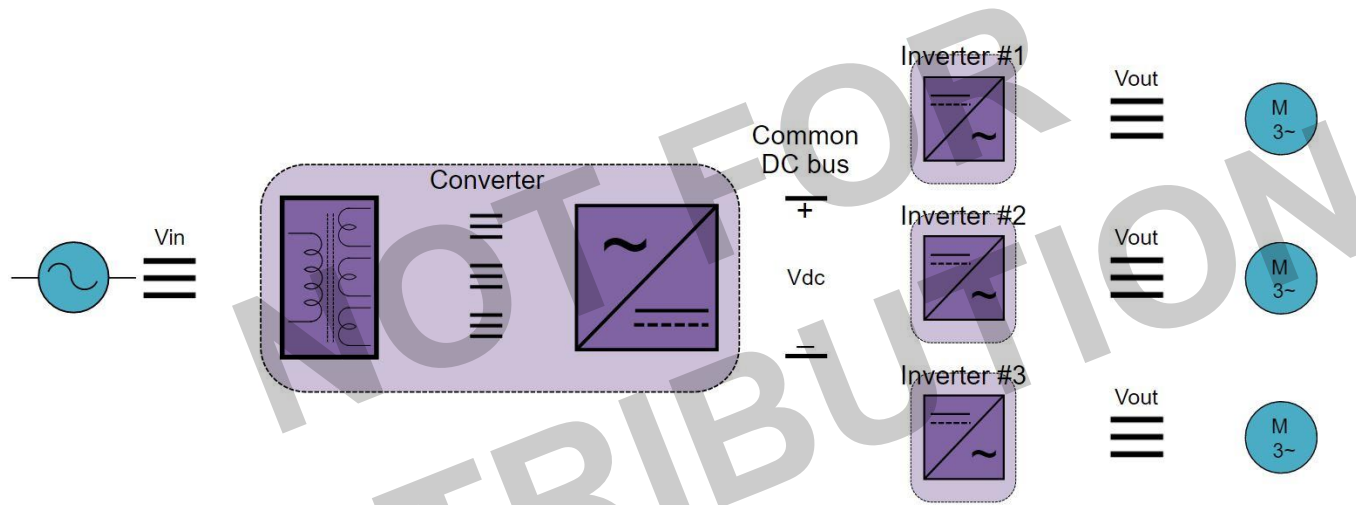

- Optimized solution for applications with multiple motors
- Significant cost savings on equipment and real estate
- Independent or integrated control
- Minimized component count

M2L MV Drive



Safety in Mind!

- M2L drive is designed with a focus on safety.
- Outdoor transformer
 - Reduced indoor short-circuit rating
- Modular design
 - Distribute and limit arc flash energy
- Local arc flash detection sensors
 - Fastest arc flash detection system
- Advanced control and reliable communications
 - Fast downstream isolation
 - Reliable upstream isolation



This never happens!

Safety in Mind!

- This type of arc flash protection system fights arc flash with limiting the amount of energy by detecting arc locally and isolating fault very fast.
- Each power cell is equipped with a photodiode flash detection sensor which gets activated in neighborhood of light with a very specific characteristics.
- The power cell that detects the arc flash light level will turn it's IGBT off within several microseconds.
- The remaining power cells stop switching in maximum another ~150 us.
- Additionally, a signal will be sent to the upstream breaker from main controller in maximum ~50 us to remove the source of power.



Medium Voltage Drives



Final words

- Keep it cool
- Keep it dry
- Keep it clean

NOT FOR DISTRIBUTION

Questions?

Contact: navid.binesh@ieee.org

