

EXAMPLE OVERALL PLANT SINGLE LINE DIAGRAM

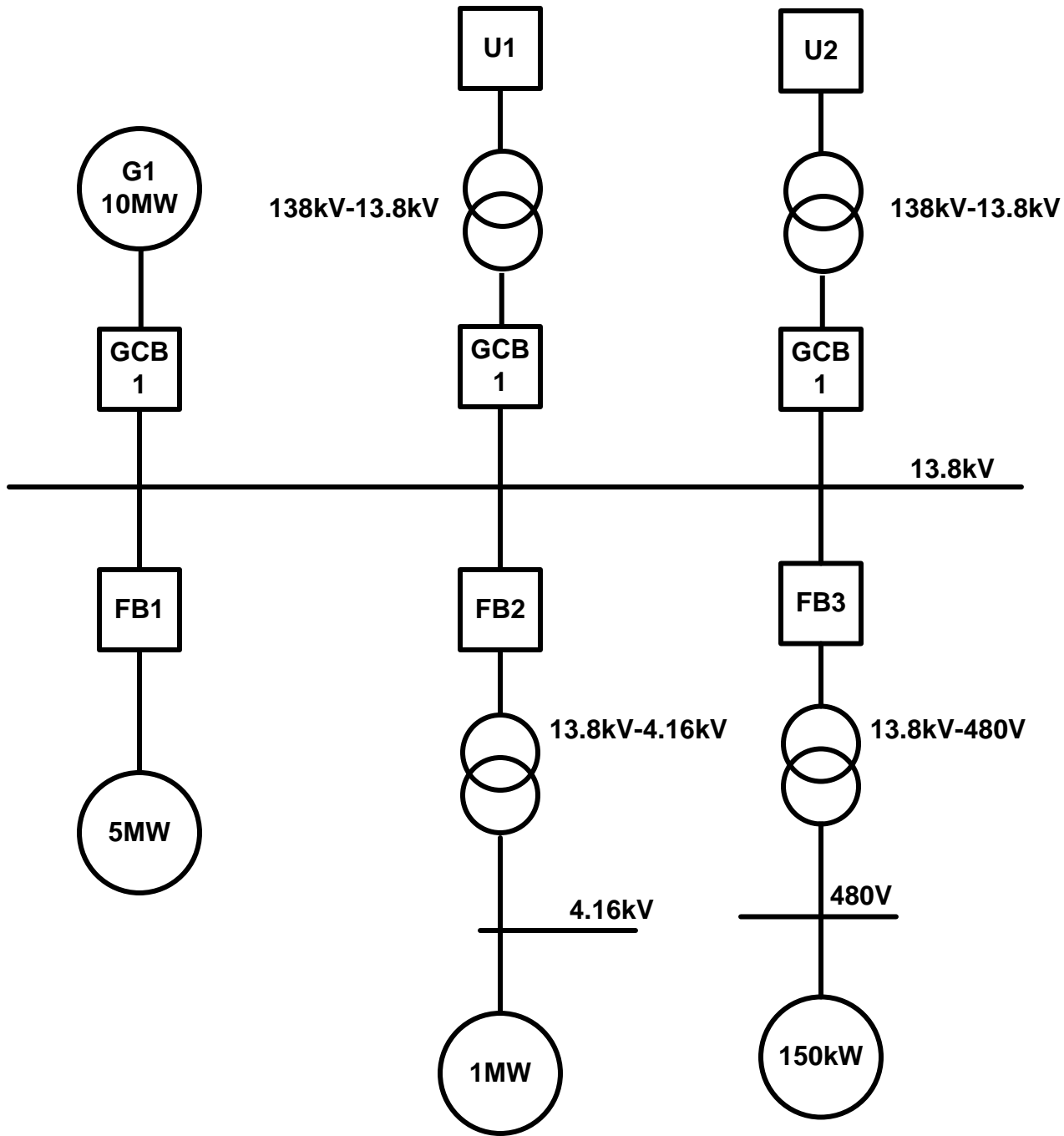

EXAMPLE PLANT COGEN

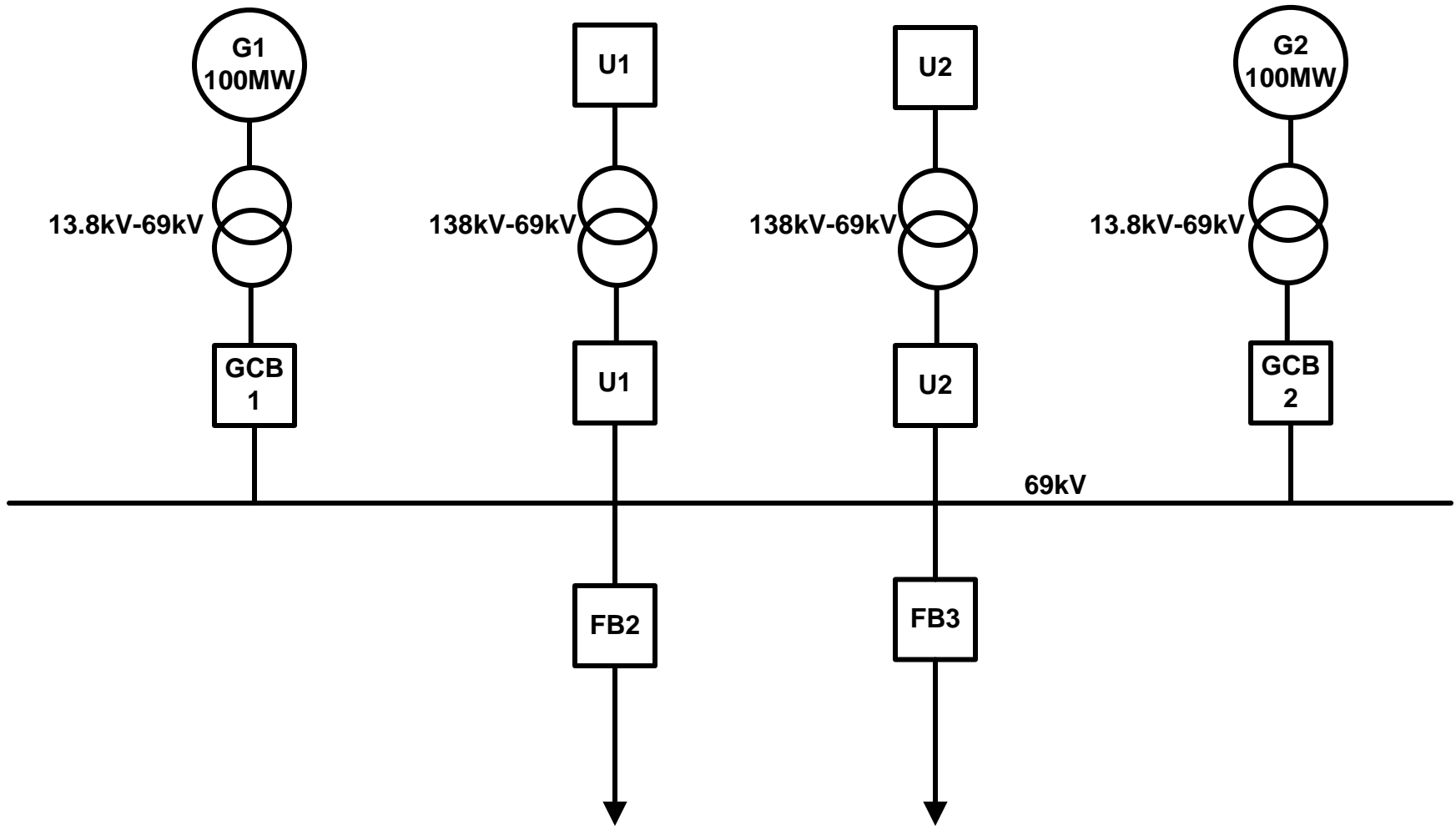

EXAMPLE COGEN – 69KV DISTRIBUTION

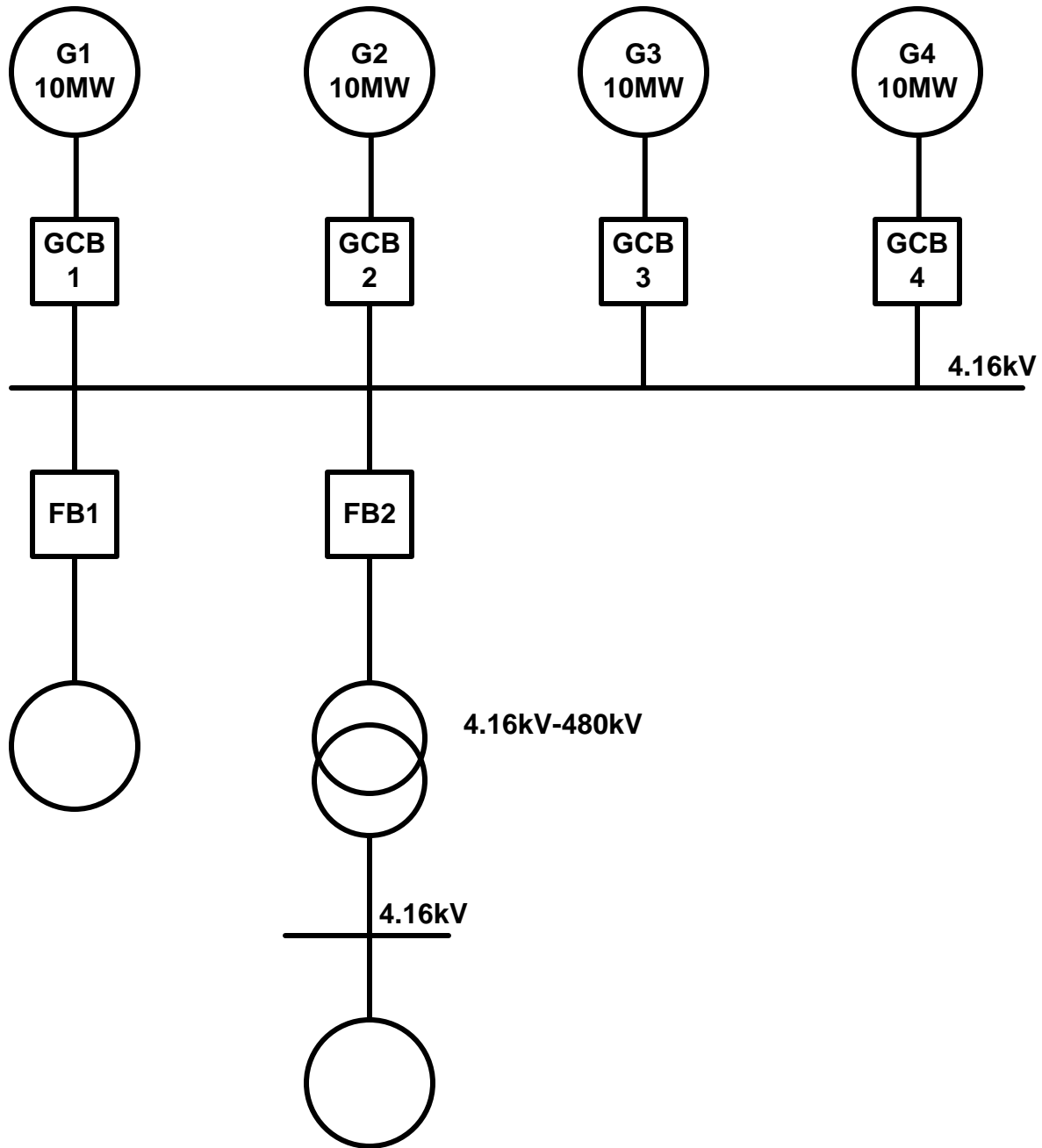

EXAMPLE OFFSHORE SINGLE LINE DIAGRAM

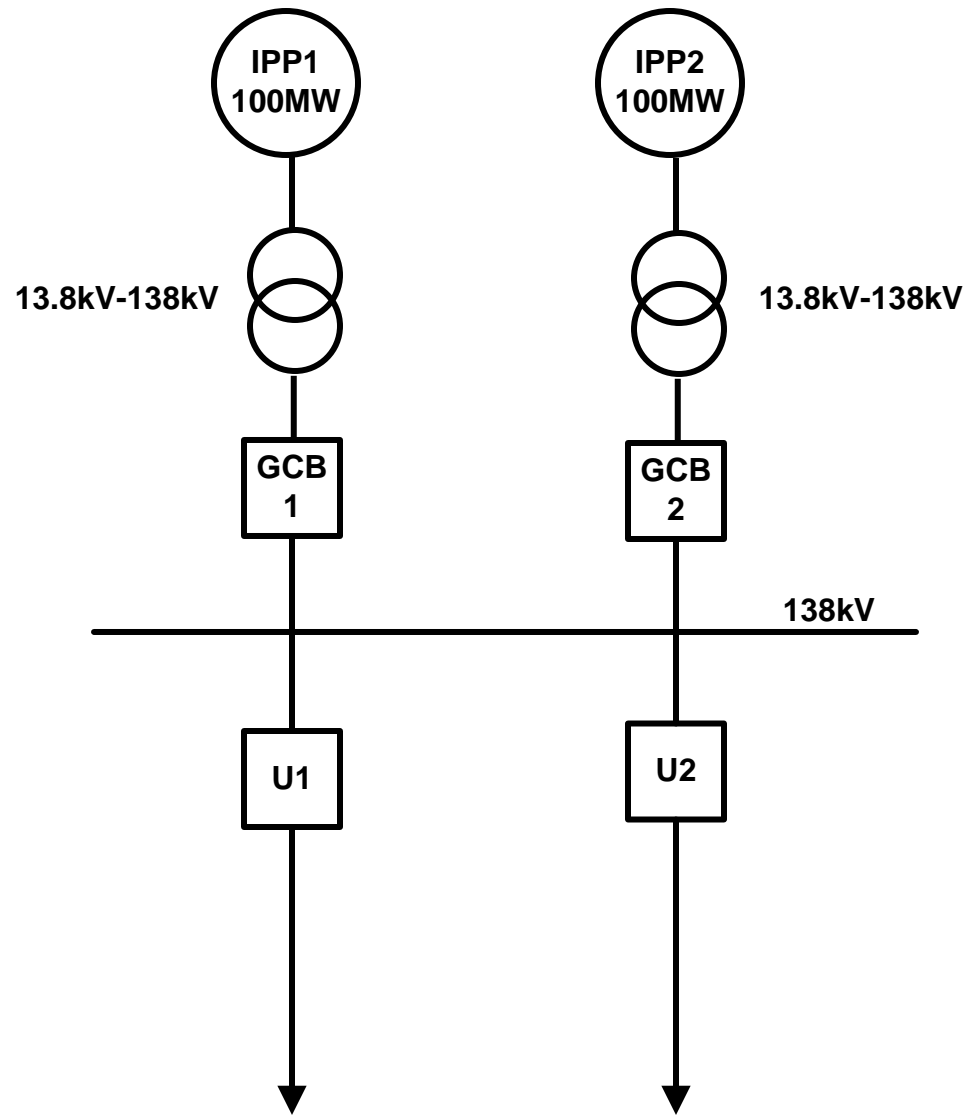

EXAMPLE IPP

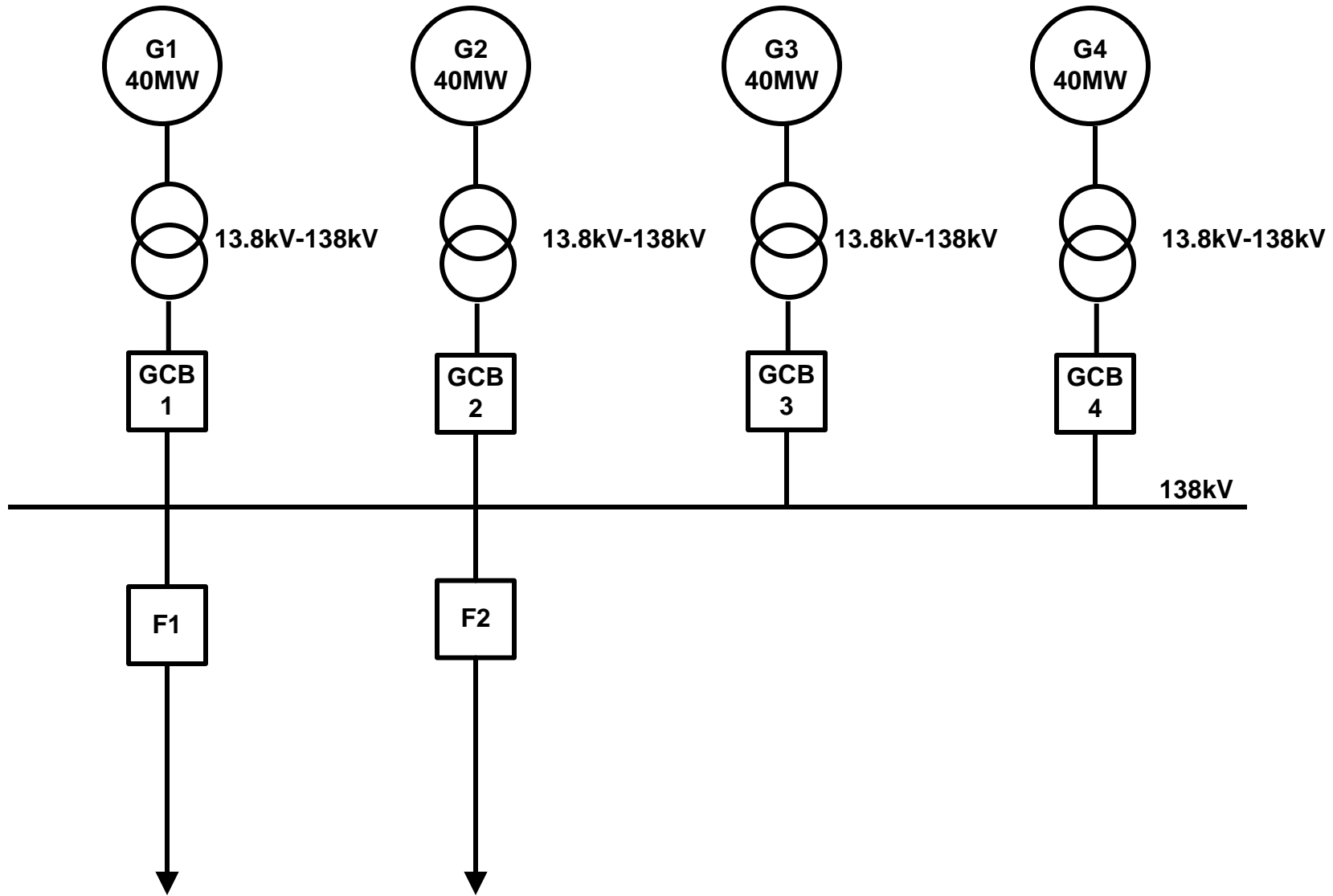

EXAMPLE ISLAND 138KV

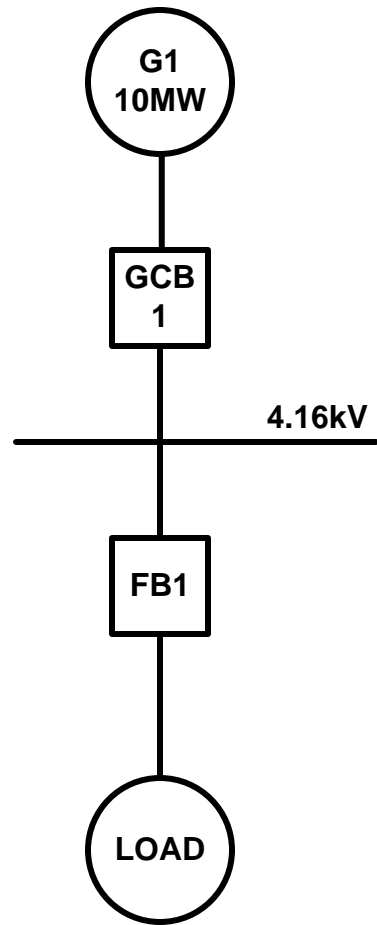

**EXAMPLE ISLAND
BUS CONNECTED / 1 GTG**

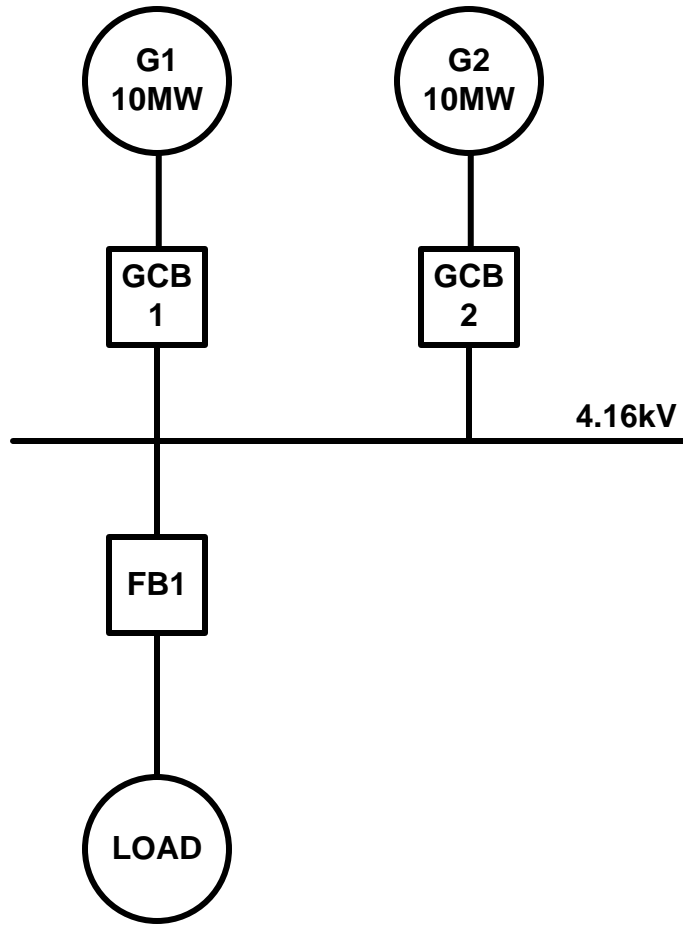

**EXAMPLE ISLAND
BUS CONNECTED / 2 GTG**

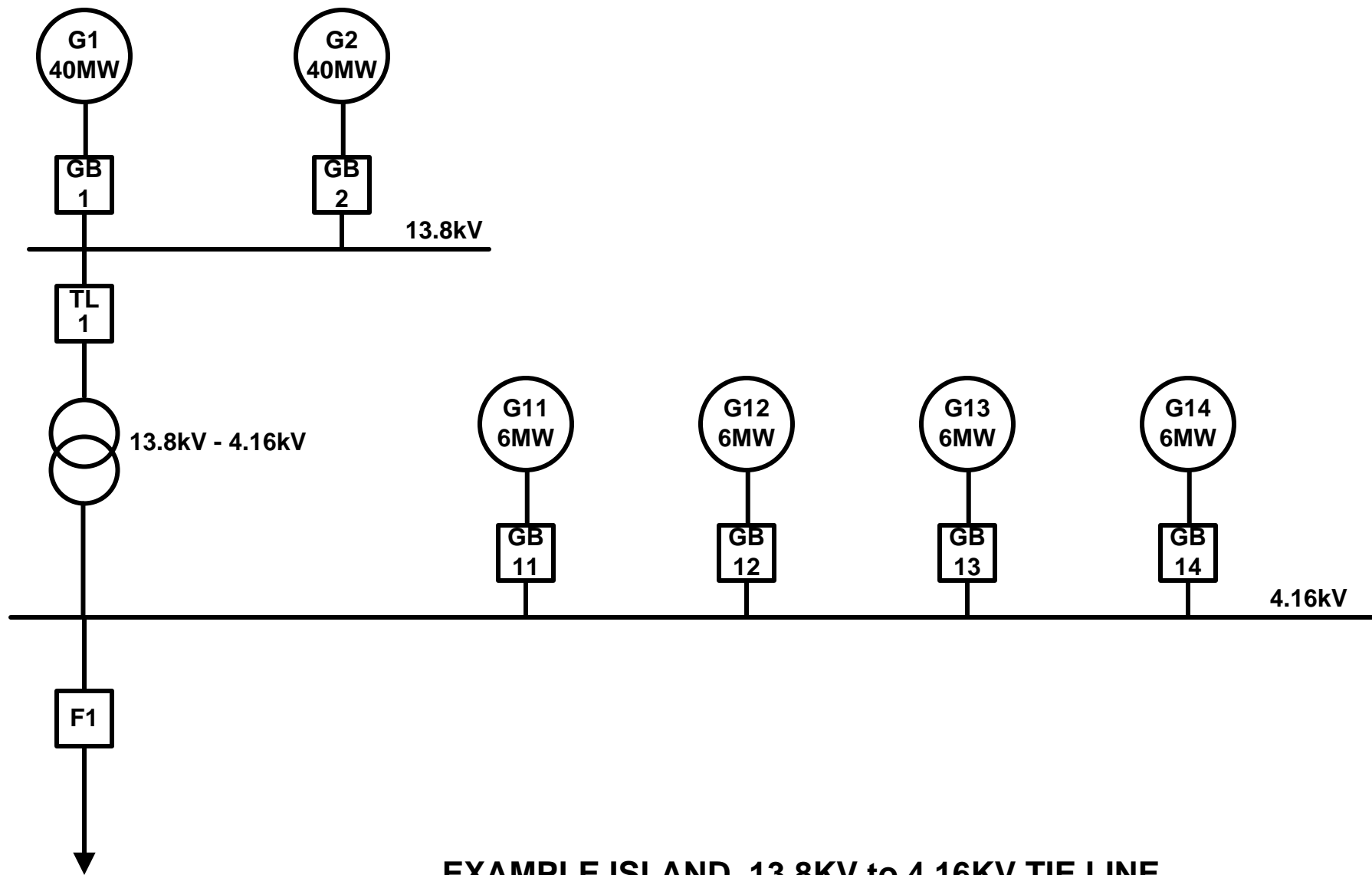

EXAMPLE ISLAND 13.8KV to 4.16KV TIE LINE

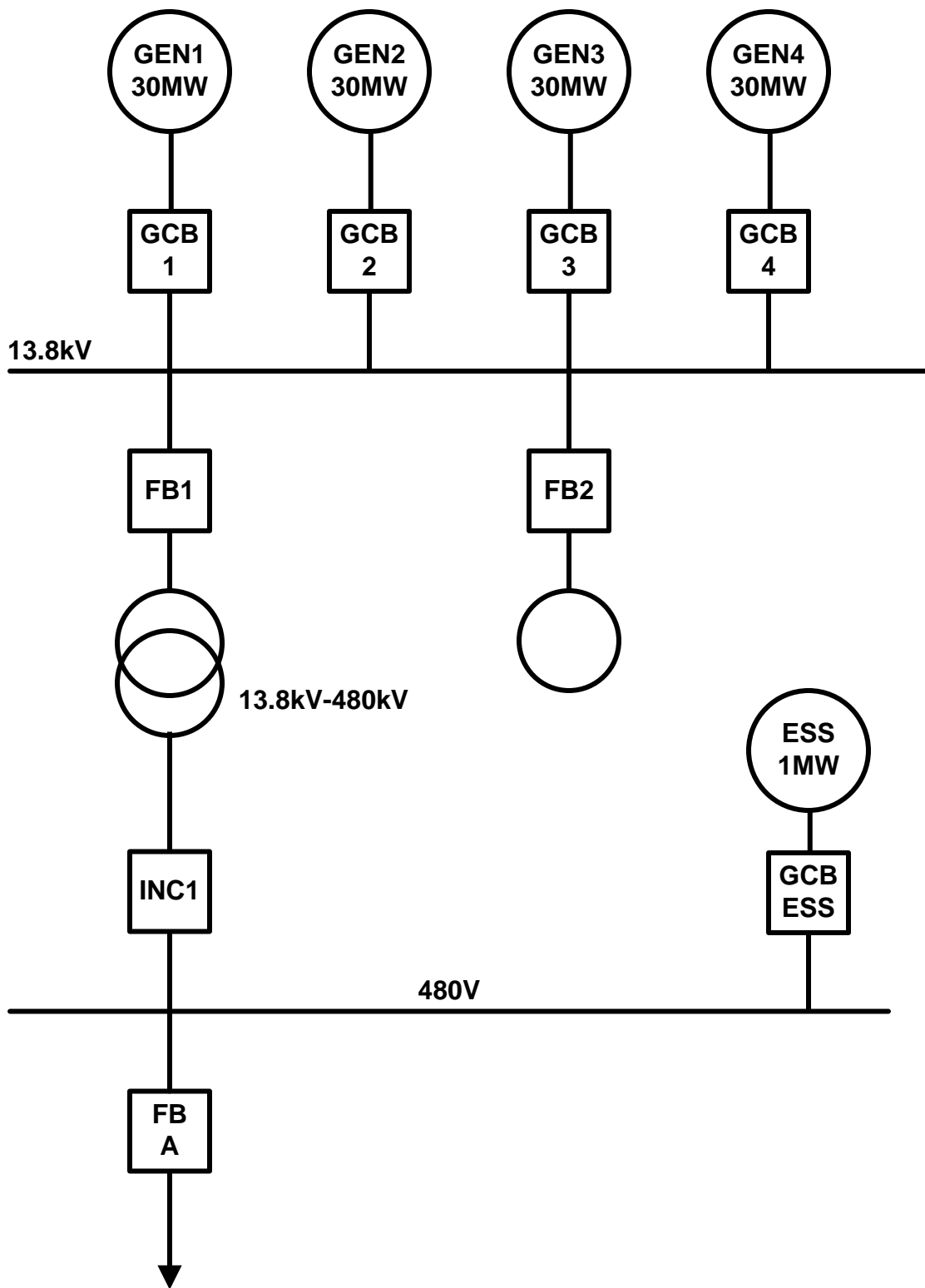

EXAMPLE WEEKLY DIESEL EXERCISE

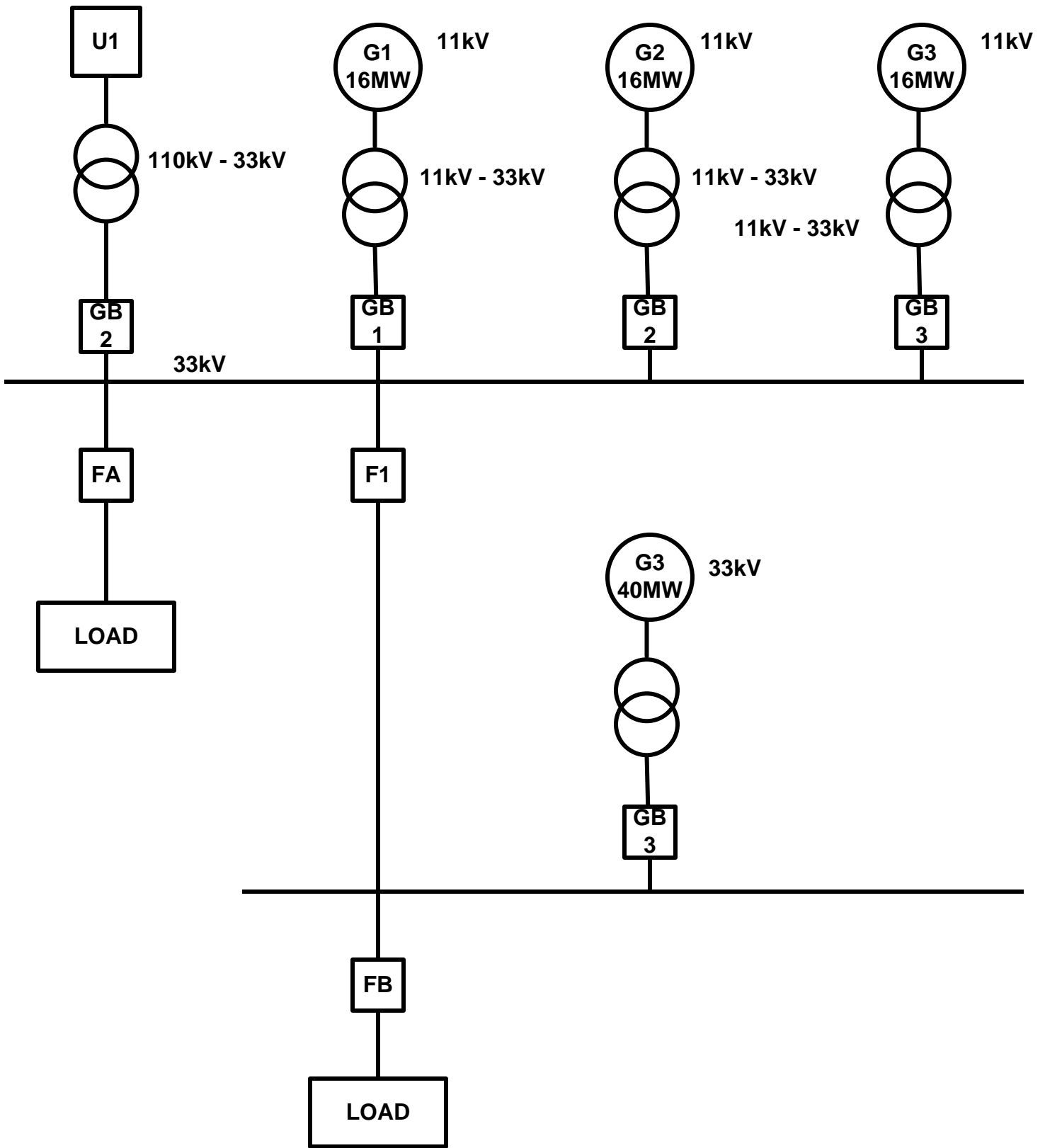

EXAMPLE 33KV SYSTEM with UTILITY TIE LINE

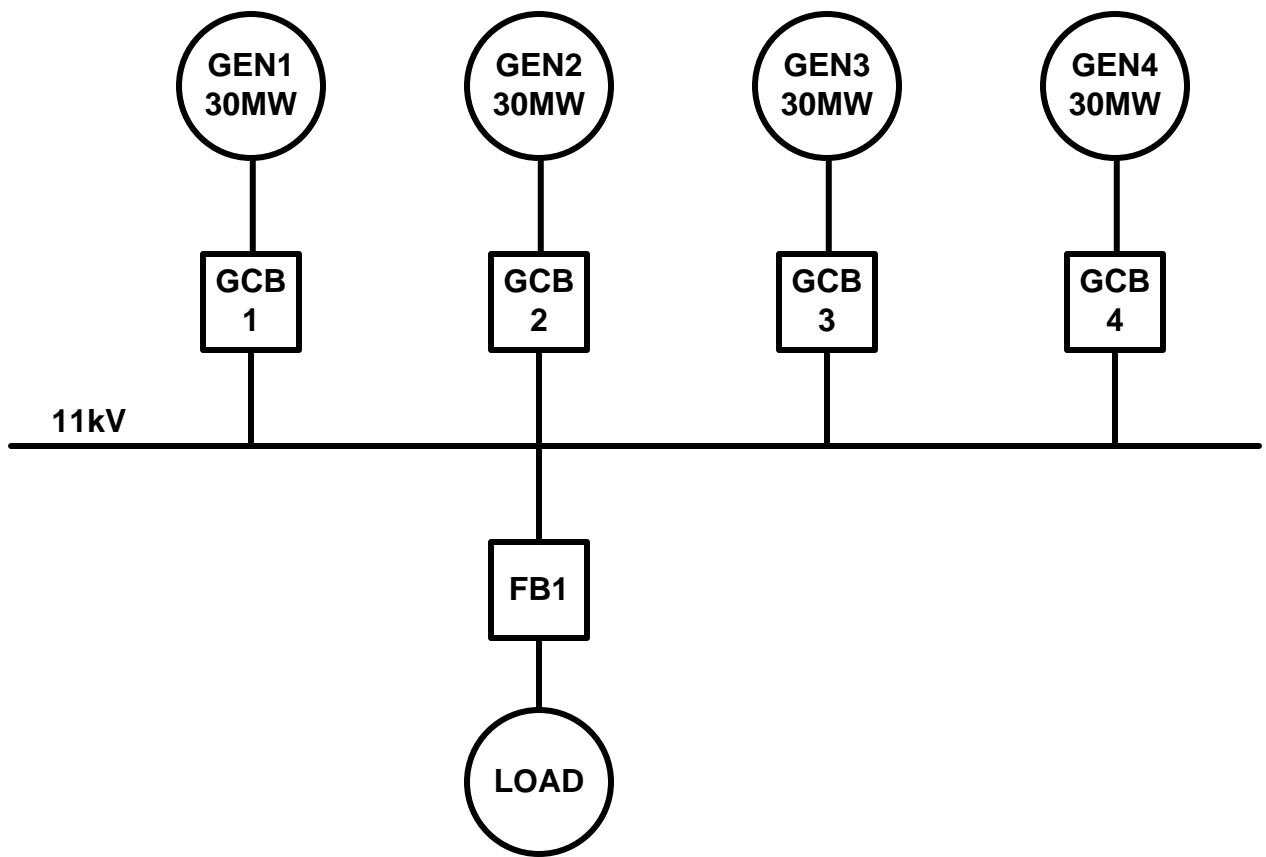

**EXAMPLE ISLAND
BUS CONNECTED / 4 11KV GTG**

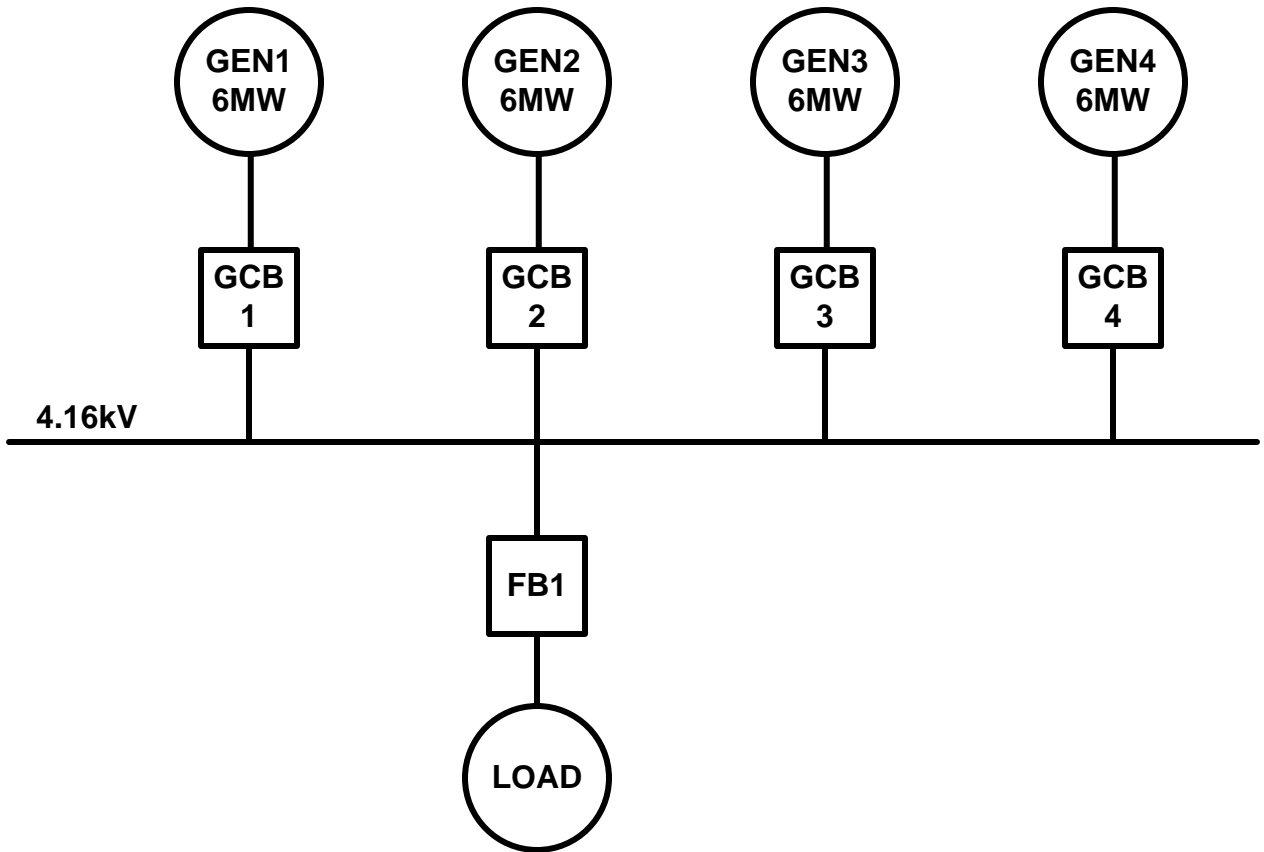

**EXAMPLE ISLAND
BUS CONNECTED / 4 MV GTG**

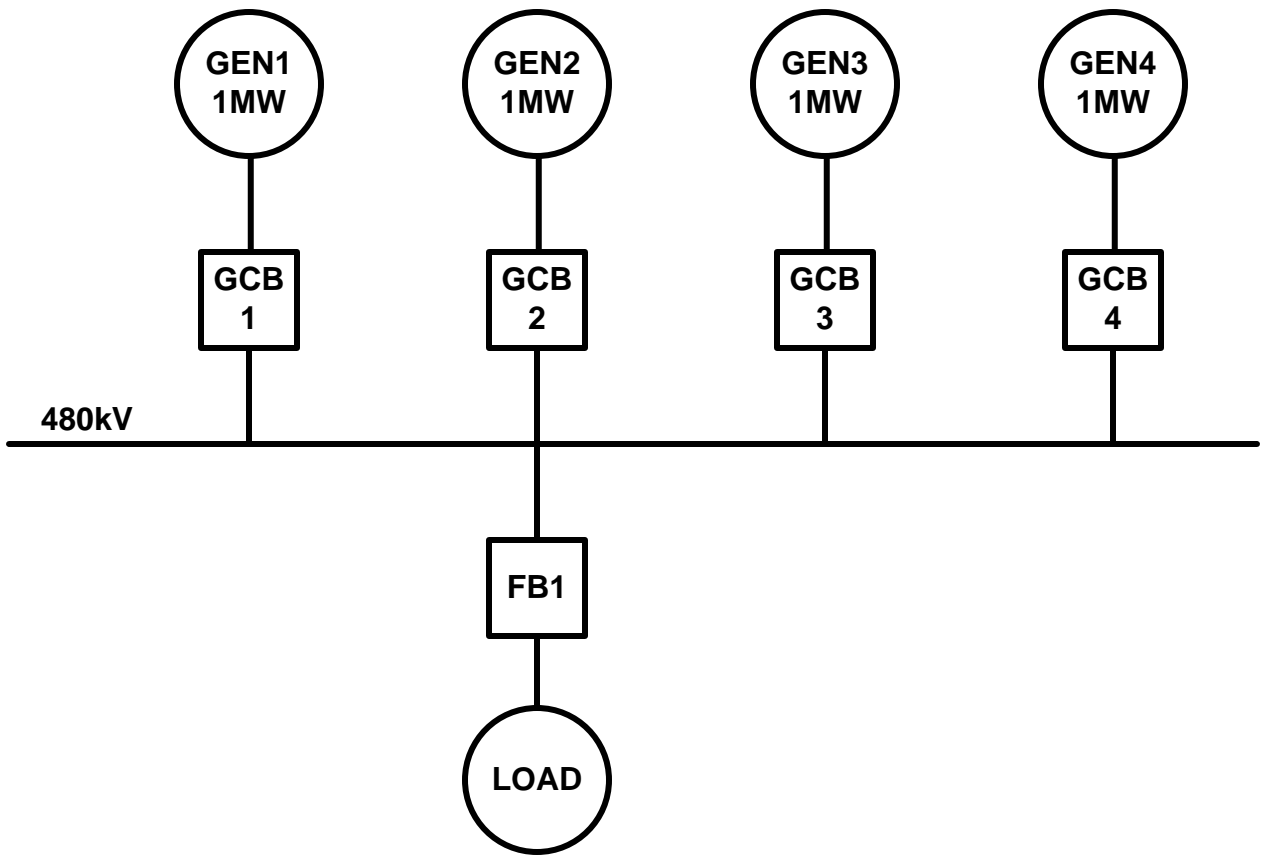

**EXAMPLE ISLAND
BUS CONNECTED / 4 LV DIESEL**